

3 Must-have Products

To Realize High-precision CNC Machining

TOOL SETTER
for Tool Wear Detection

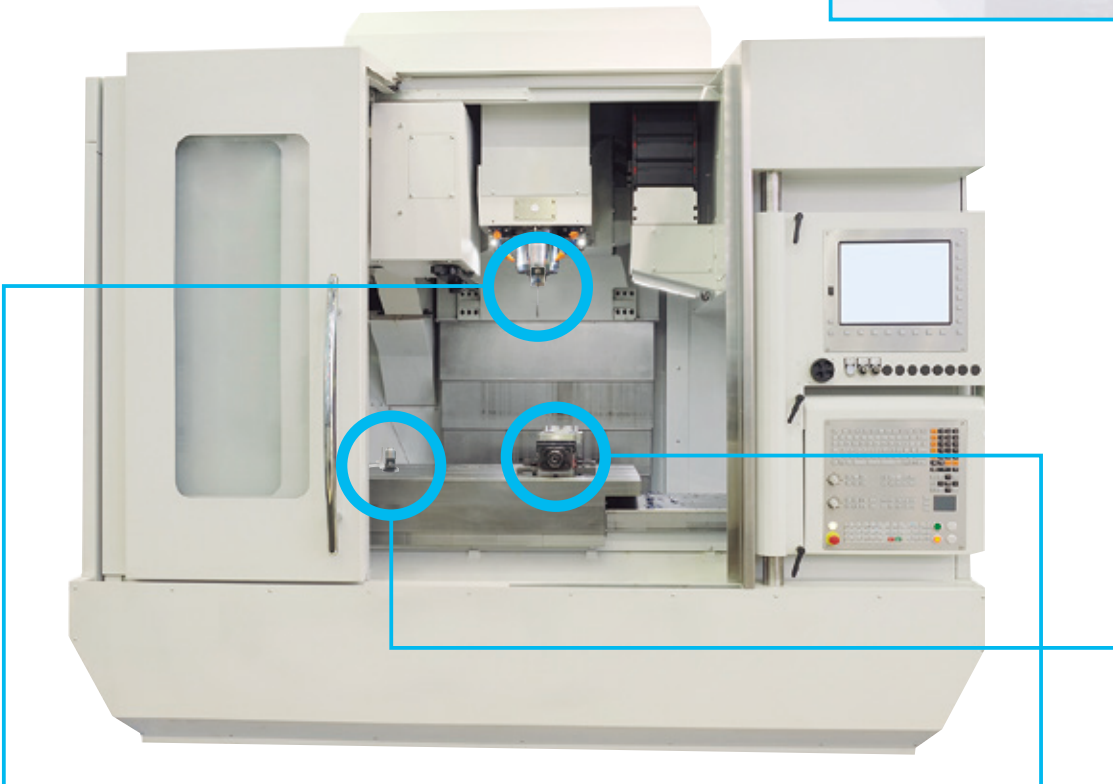

WIRELESS TOUCH PROBE
for Workpiece Measuring

NEW

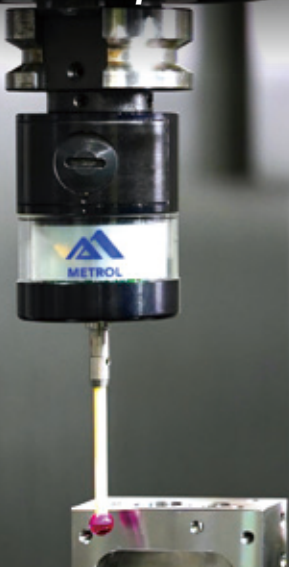

AIR GAP SENSOR
for Precision Seating Confirmation

IO-Link



TM26D



TOOL SETTERS

for CNC Machine Tools

[TM26D]

The world's best-selling tool setters.
Achieving an production volume
of 600,000 vehicles.

Tool setters can be used to detect wear and breakage and correct thermal distortion as well as to preset tool length.

1 1µm repeatability

Improve machining accuracy in the CNC lathe

2 Enhance productivity

Avoid machining problems in unmanned operation

3 Prevent defective products

Eliminate the need for expertise in tool setting

External Dimensions Diagram

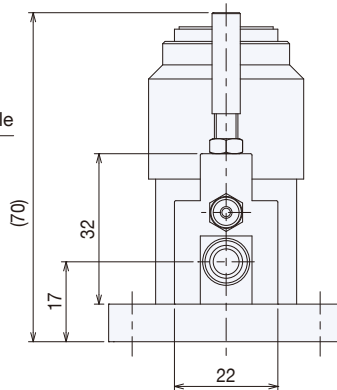
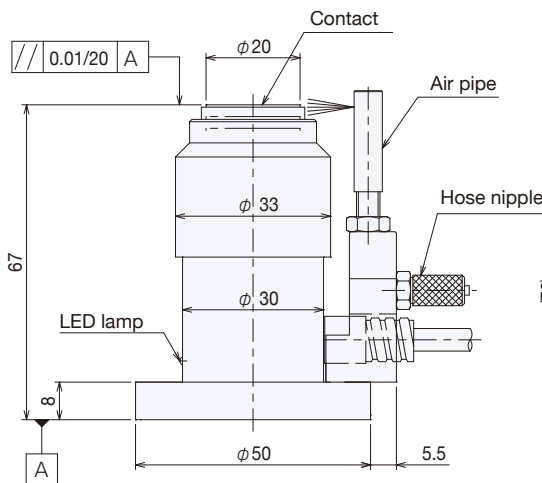

● Circuit diagram

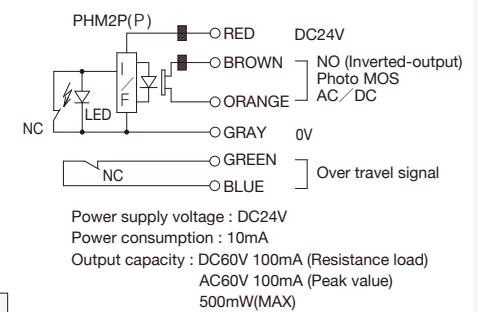

Specification

Product No.	TM26D
Contact diameter	φ20
Contact material	Tungsten carbide
Contact structure	NC (Normally closed)
Output mode	NO (Normally open)
Pretravel	0
Stroke	5
Repeatability	0.001 (Recommended operating speed of 50 - 200mm/min)
Contact life time	3 million

Protective	IP67
Contact force	1.5N (Installation position: Vertical)
Contact rating*	DC5V - DC24V Steady Current: 10 mA or Less Rush Current: 20 mA or Less
Cable	Oil resistant φ 4.8 / 6 cores Tensile strength 30N, Minimum bending R7
LED lamp	Default : LED OFF / Operating : LED ON

Over travel signal (built-in microswitch)

Output mode	NC (Normally closed) "About 2.5mm from skip signal"
Contact rating	DC24V 100mA resistance load

RC-K3X

NEW

High-precision Wireless TOUCH PROBE [RC-K3X]

Low Cost Easy Install Product is here!

Improve productivity by On-machine measurement in 5 axis machine and robot, not accept infrared wireless probe

- 1 High quality in reasonable price from Japan
- 2 1 μ m 2 σ Repeatability
- 3 2.4GHz radio transmission system

Performance comparison



Metrol's new wireless transmission system

Uninterrupted by coolant or noise

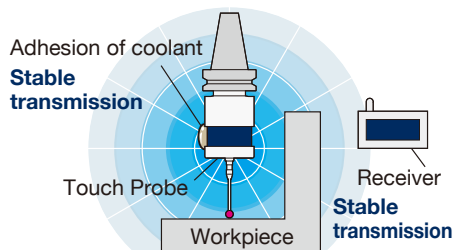

Conventional infra-red optical communication

Affected by obstacles and coolant

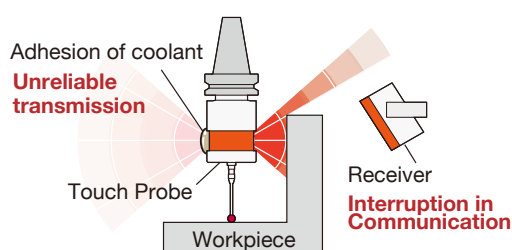

Specification

Repeatability	0.001 (2 σ) (Recommended operating speed of 50 - 500mm/min)*
Life time	3 million times
Sending Directions	5 directions \pm X \pm Y +Z
Overtravel	XY directions : \pm 13° +Z direction : 4mm
Contact signal	1 point NC
Wireless frequency	2,404MHz~2,476MHz
Certification	Radio raw
Signal transmission range	MAX.15m (Line-of-sight distance)
ID control	Connect to ID number of the receiver paring with sensor head(Number of communicable unit: 1)

Protective structure	Automatic change for IP68
Operating environment	For indoor use only
LED display	Sensor head: LED 2 points LEDs(POWER, BATTERY, TOUCH#1,#2,#3)
Operation temprature	5°C~50°C : 20%~80% (Ice-free)
Weight	Sensor head : approx.130g with battery Receiver : approx.290g
Battery	½AA Lithium-thionyl chloride battery : 2 pcs
Receiver power supply	DC24V \pm 10% 100mA

*Based on an vertical inspection with the standard stylus 40mm

DPA series



IO-Link
Standard is applied

AIR GAP SENSORS

[DPA]
SERIES

Workpiece precision seating confirmation can be realized.

Effectively prevents CNC industrial machined defect products by detecting workpiece floating due to cutting chips.

1 ±0.5μm repeatability

2 IP67 coolant proof

3 One-push master setting

Performance comparison between Air Gap sensor and Conventional sensors

	METROL' s AIR GAP SENSOR	Conventional Air sensor/Gap sensor
Repeatability	✓ ±0.5μm~ "Precision seating confirmation" is possible	✗ ±2.5μm~ Only "existence detection" is possible
Detection range	✓ 1~350μm	✗ 10~300μm
Protective structure	✓ IP67 (Internal installation) (Can be used under harsh environment with coolant)	✗ IP66 (External installation) (Not suited for harsh environment with coolant)
Response speed	✓ 0.8 sec (tube length:1.5m) Air piping can be shortened by installing sensor inside machine tools	✗ About 5 sec (tube length:12m) Longer air piping is necessary because sensor should be installed outside machine tools
Numeral display	✓ No display (only ON/OFF signal)	✓ With display

Relationship between accuracy and detection distance

(compared to other company's products)

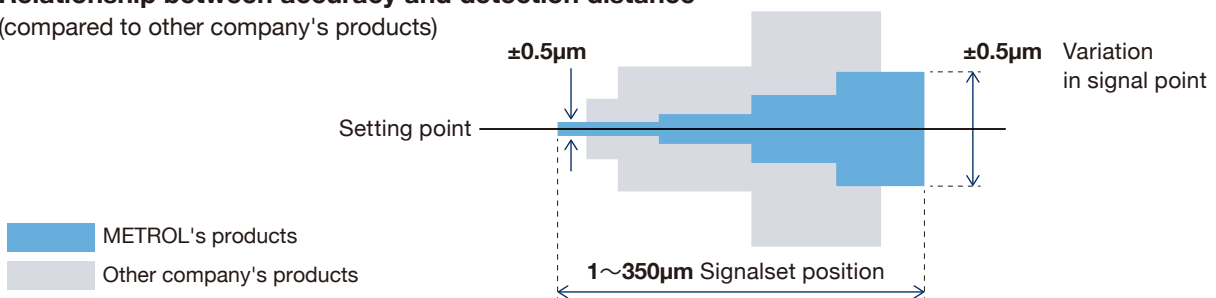

Air nozzles



IP67 Installation inside machine



One-push signal setting

Case Study

Ultra-precision machining can be realized by checking the precise seating of workpiece in jig. Effectively prevents defect products.

✗ 10µm gap caused by cutting chips cannot be detected

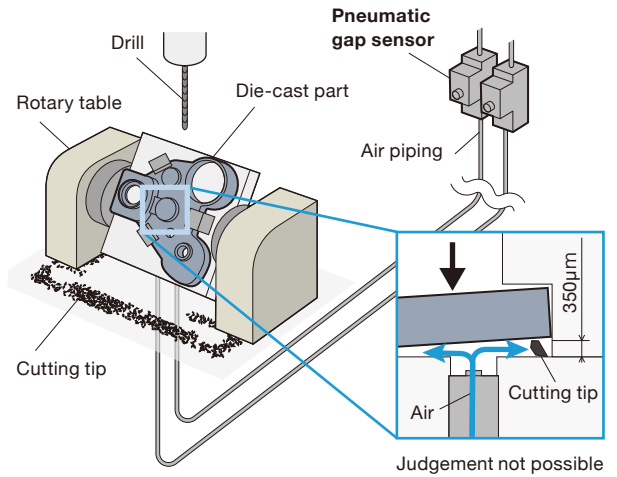
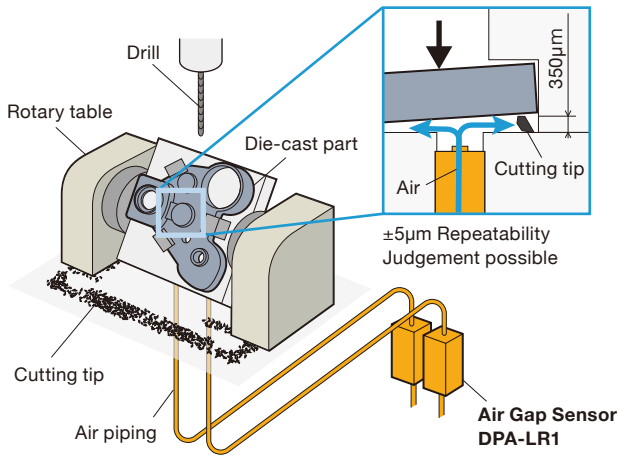

World's First

Full automation of CNC grinder workpiece measurement



AIR GAP SENSOR for Precise Positioning of Rotating Grind wheel

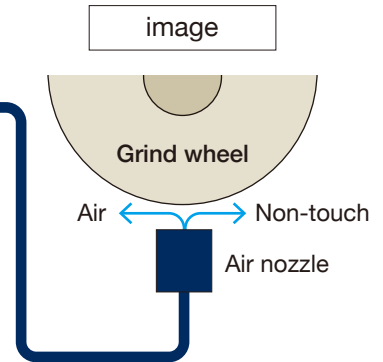

Mounting example: Okamoto Machine Tool Works, Ltd.: CNC high-precision form grinder HP500NCS

IO-Link standard Air Gap sensor

Remote control

Condition monitoring

Predictive maintenance

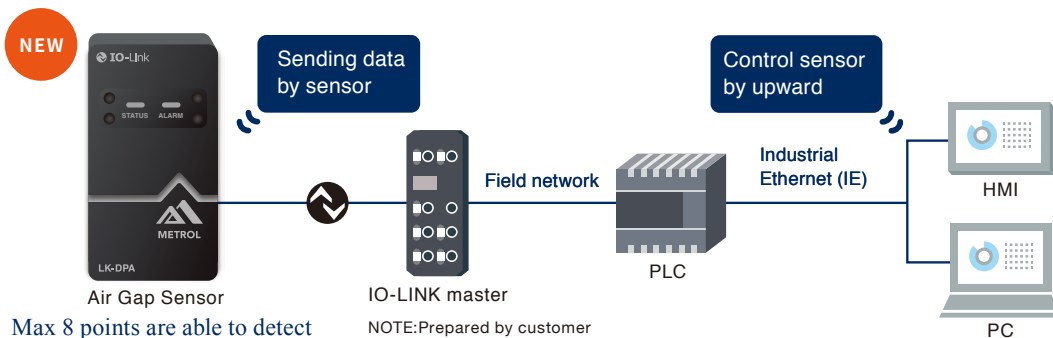

K3S series

NEW

Ultra-small TOUCH PROBE [K3S] SERIES

The world's smallest size $\phi 17.8\text{mm}$ ~.
It provides ideal on-machine measurement.

Touch probe "K3S" series for On-machine measurement in Grinder/ CNC Automatic Lathe.

- 1 The smallest size for CNC machine tools
- 2 $1\mu\text{m } 2\sigma$ Repeatability
- 3 IP68 Waterproof

Specification

Use	Measuring workpiece dimensions, Zero point setting
Sensing directions	3 Dimensions (X, Y, Z)
Repeatability*	0.001 (2 σ) (Recommended operating speed of 50 - 500mm/min)
Contact force	X,Y directions Z direction
Stroke	X, Y = $\pm 9^\circ$ Z = 3.5mm
Protective structure	IP68
Preravel	0

*Based on an inspection with the standard stylus 20.5mm

External Dimensions Diagram

K3S-I-001S (Mounting method: **Set screws**) Material: Stainless steel

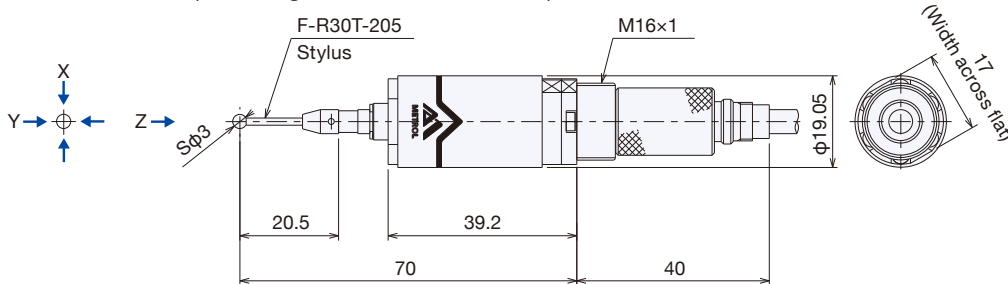

Connector attachment/
detachment part

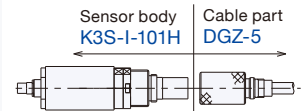

K3S-M-001S (Mounting method: **Flange**) Material: Stainless steel

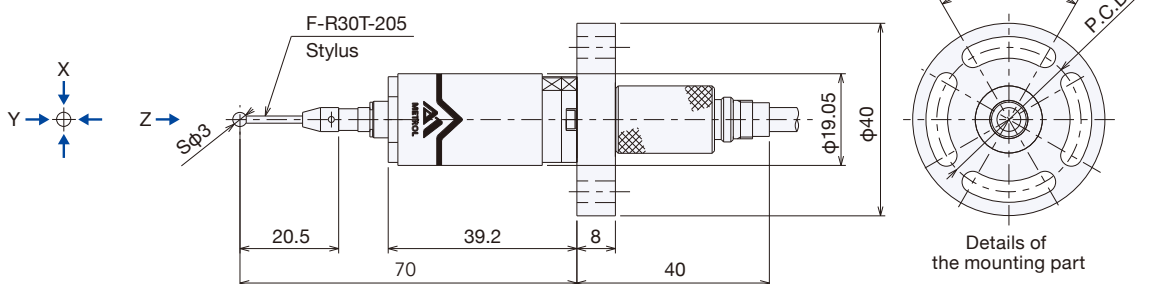

Case Study 1 | Full automation of CNC grinder workpiece measurement



Touch probe for workpiece measurement

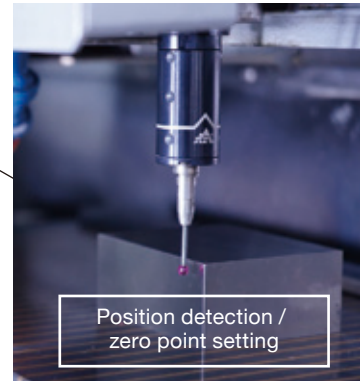

Mounting example:
Okamoto Machine Tool Works, Ltd.: CNC high-precision form grinder HP500NCS

Measurement Image

(1) Setting zero point

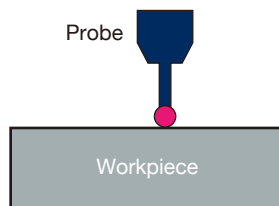

(2) Grinding

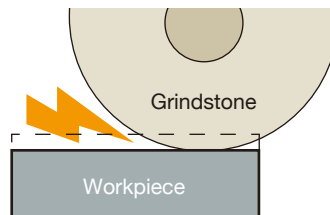

(3) Measuring height after machining

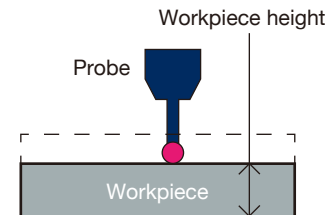

Case Study 2 | Workpiece inside & outside diameter inspection in the CNC lathe

In-machine installation example

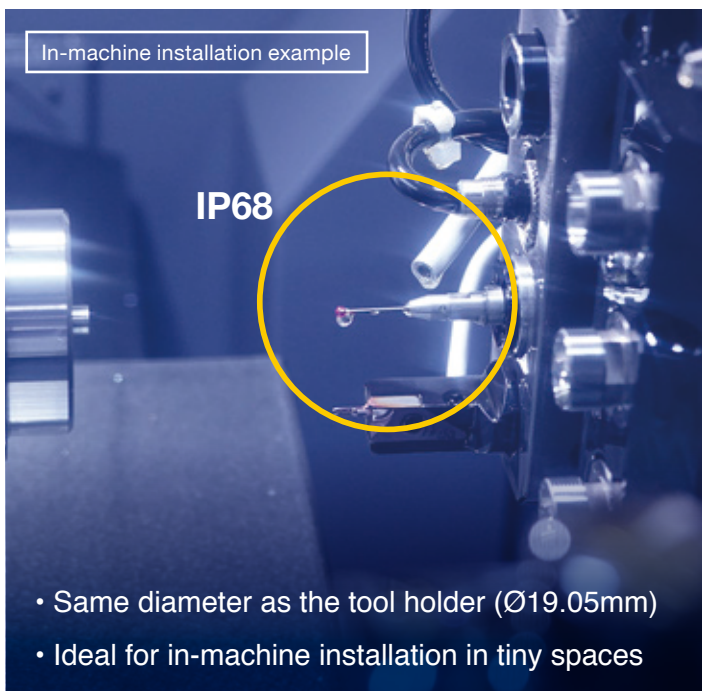

- Same diameter as the tool holder (Ø19.05mm)
- Ideal for in-machine installation in tiny spaces

Mounting example:
CITIZEN MACHINERY: CNC lathe Cincom

Workpiece example

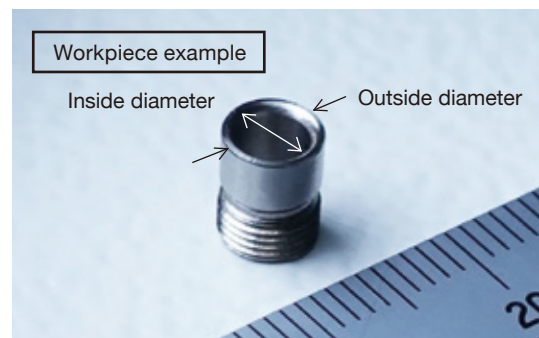



About METROL

Founded in 1976.
METROL specializes in manufacturing High-precision Sensors/Switches.

METROL has developed “precision mechanical switches/sensors”, while most industrial sensors were electrical.

This was unlike any other in the world.

Our High-precision switches/sensors can work in high accuracy even under harsh working conditions where coolant and cutting chips splatter.

We also own more than 50 patents both inside and outside Japan for their originality.

In machine tool industry, METROL tool setters are widely used by more than 70 machine tool builders in 17 countries.

We have been dedicated to contribute manufacturers by improving machine accuracy and reducing costs.

Our products are now used in not only long standing automobile industry and machine tool industry but also in leading companies in semiconductor, robot, medical equipment and smartphone industries.

Our unique and distinct product development is supporting manufacturing across the world.

UPGRADE & RETROFIT!

Various Tool Setters and other sensors for CNC Machining Centers are available.

Metrol Co., Ltd.

metrol-sensor.com

TEL: +81-50-5558-7366

E-mail: touchsensor@metrol.co.jp

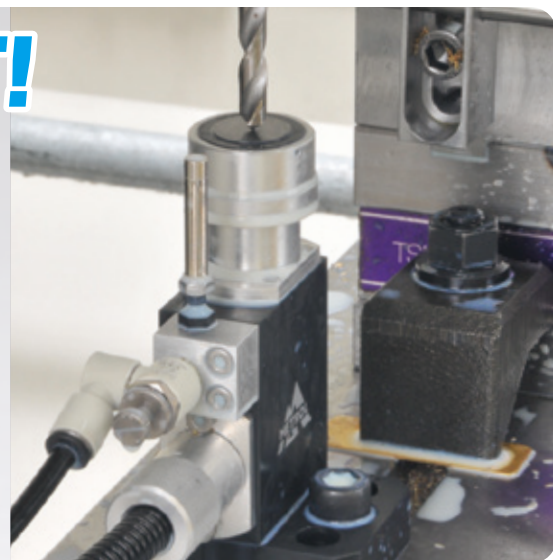

The specifications and descriptions are subject to change without notice due to improvements in products.



METROL CO., LTD.

1-100 Takamatsu-cho Tachikawa, Tokyo 190-0011 JAPAN

Tel: +81 50 5558 7366 / Fax: +81 42 528 1442

LEAF-CNC-EN-K003