

# SENSOR AND SWITCH CATALOG

- HIGH-PRECISION POSITIONING SWITCHES
- For CNC Machine Tools TOUCH PROBES/TOOL SETTERS

# 2020

## FEATURED PRODUCTS

---

### ■ All-purpose High-Precision Switch Series

- Air Gap Sensor
- Ultra-small precision PT-Touch Switch
- High-precision MT-Touch Switch
- CS-Touch Switch
- Machine Components with a Built-in Switch Series
- Special Purpose Switch Series

### ■ CNC Machine Tools Series

- Touch Probes for CNC Machine Tools
  - Tool Setters for CNC Machining Centers
  - Tool Setters for CNC Lathes
  - Drill Bit Breakage Detection Sensor
- 

[www.metrol.co.jp/en](http://www.metrol.co.jp/en)

No. **10**-2E



**Founded in 1976**

The origin of "METROL" stands for  
**MEASURE** and **CONTROL**

---

***METROL specializes in manufacturing  
High-precision positioning switches.***

*We provide the "industrial switch" with superior repeatability, reliability and cost performance in all industries to meet your needs for automation, labor saving and defect prevention.*

---

### 《Our Products》

- \*Not applicable to the Export Trade Control Ordinance.
- \*Not applicable to the CE-mark Machine Directives and Low Voltage Directives.
- \*Our products use lead-free solder.
- \*Our products comply with RoHS Directive.
- \*Export Trade Control Ordinance is not applicable for section 1-15 of other table. It is applied for section 16 (Catch-all Controls).

(Catch-all Controls)

Application to the Ministry of Economy, Trade and Industry is needed, when in principle, all goods and technology become objects and if there is a risk related to weapons of mass destruction, etc.

### Help desk

We accept inquiry regarding switch selection, exclusive specification, and technical matter through website, Fax, and Tel listed below.

**[www.metrol.co.jp/en](http://www.metrol.co.jp/en)**

 **[touchsensor@metrol.co.jp](mailto:touchsensor@metrol.co.jp)**

**TEL +81-50-5558-7366**

**FAX +81-42-528-1442**

# Terms of Warranty

Before using our products, we would like to request that our customers have an understanding of our warranty policy and the functions and specifications of applicable products as indicated by our catalogs, instruction manuals and website to ensure that they are used properly under specified conditions.

## 1) Applicable Products

The warranty defined below is applicable to products manufactured and sold by METROL (to be referred to as the "applicable products").

## 2) Warranty Period

The warranty for applicable products is valid for one year and three months from the original delivery date to the location designated by the customer.

*\*Durability, life time and repeatability are described based on our test conditions. Please note that the performance is not guaranteed under your specific usage environment.*

## 3) Range of Coverage

- a. A replacement product will be provided on an exchange basis or the malfunctioning product will be repaired free of charge within the warranty period. If the product is or becomes defective and, at the sole discretion of METROL, the defects are due to faulty materials or workmanship.

However, applicable products will not be covered by the warranty in the case of the following malfunctions even within the warranty period.

- ( I ) Malfunctions due to use of a product in a manner that deviates from standards, specifications, environments, usage procedures or usage precautions described in the catalog, instruction manual or specifications.
  - ( II ) Malfunctions having occurred for reasons other than those attributable to the delivered product.
  - ( III ) Malfunctions having occurred due to disassembly, modifications or repairs made by someone other than a Metrol representative.
  - ( IV ) Malfunctions or damage that results from external causes outside our control which shall include accidents, fires, natural disasters, or other force majeure.
- b. The range of coverage is limited to the warranty of the applicable product only, and any other secondary loss or damage resulting from the malfunction of an applicable product is not covered by the warranty.
- c. Please be aware that we do not offer installation, uninstallation, on-site confirmation, or repairs.

## 4) Applications

Applicable products are designed and manufactured as general-purpose products used in ordinary industrial environments.

In the case of incorporating an applicable product in an apparatus, machine or system, please confirm the suitability of the application along with any related standards, regulations, and restrictions.

With respect to the applications indicated below in particular, customers are requested to conduct the necessary tests regarding usage conditions and other details on an actual product in advance.

- a. Applications for which usage conditions or environment are outside those presumed by the manufacturer or applications unable to be confirmed as being appropriate by the manufacturer when using applicable products.
- b. Applications likely to have an effect on human life or property (such as nuclear power equipment, transportation machinery or medical devices), applications used in public utilities (such as electricity, gas, or water lines), or applications applying correspondingly thereto.
- c. Applications in harsh environments (special environments requiring heat resistance, vacuum, and the like)

## 5) Attention

- The contents of this catalog, including specific models, specifications, and any other contents, are subject to change without notice at METROL's sole discretion.
- Durability, life time and repeatability are described based on our test conditions. Please note that the performance is not guaranteed under your specific usage environment.
- The rightmost number of the Ingress Protection (IP) code represents a product's resistance to water only and may not apply to coolants.

# INDEX

## All-purpose High-Precision Switch Series ..... P1-3

### Air Gap Sensor series ..... P2-1

**1 Signal Point Setting Type**



- 1-100μm  
Short range detection type  
**DPA-SR1** ..... P2-2
- 80-350μm  
Long range detection type  
**DPA-LR1** ..... P2-2

**2 Signal Point Setting Type**



- 1-100μm  
Short range detection type  
**DPA-SR2** ..... P2-4
- 80-350μm  
Long range detection type  
**DPA-LR2** ..... P2-4

**3 Signal Point Setting Type**

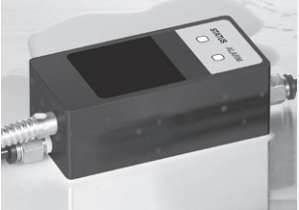

- 80-350μm  
Long range detection type  
**DPA-PLR2B** ..... P2-6

### High-Precision Positioning Switch series ..... P3-1

**Ultra-small precision PT-Touch Switch**



- Straight touch type  
**PT** ..... P3-4
- Straight touch, waterproof type  
**PTP** ..... P3-4

**High-precision MT-Touch Switch**

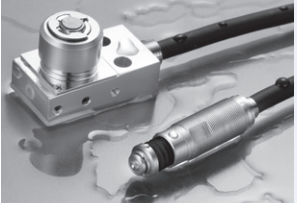



- Straight touch type  
**P08 / P10 / P12** ..... P3-10
- Sliding and angled touch type  
**P10DH** ..... P3-16
- Straight touch, Flat type  
**P11** ..... P3-22

**CS-Touch Switch**

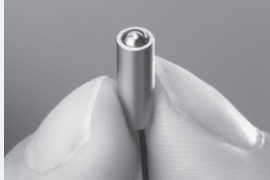

- Straight touch type **CS / CSJ / CSS / CSK / CSP** ..... P4-3
- Sliding and, angled touch type **CSHP** ..... P4-9
- Sliding and, angled touch type **CSH** ..... P4-11
- Straight touch, short type **CSM** ..... P4-13

### Machine Components with a Built-in Switch series ..... P5-1

<p><b>Stopper Bolt Switch</b></p>  <p><b>ST</b> ..... P5-4</p> <p><b>STM</b> ..... P5-10</p> <p>Mini type</p>		<p><b>Ball Plunger Switch</b></p>  <p><b>BP4S / BP5M</b> ..... P5-14</p> <p>Ultra-small type</p> <p><b>BP</b> ..... P5-16</p> <p>M6</p>		<p><b>Spring Plunger Switch</b></p>  <p><b>SP</b> ..... P5-18</p>
-------------------------------------------------------------------------------------------------------------------------------------------------------------------------------------------------	--	--------------------------------------------------------------------------------------------------------------------------------------------------------------------------------------------------------------------------------	--	-------------------------------------------------------------------------------------------------------------------------------------------------------





### Special Purpose Switch series ..... P6-1

<p><b>Low contact force Switch</b></p>  <p><b>CSF</b> ..... P6-2</p>		<p><b>Heat resistance Switch</b></p>  <p><b>HT</b> ..... P6-4</p>		<p><b>High-vacuum resistance Switch</b></p>  <p><b>GN</b> ..... P6-6</p>
--------------------------------------------------------------------------------------------------------------------------------------------------------	--	------------------------------------------------------------------------------------------------------------------------------------------------------	--	--------------------------------------------------------------------------------------------------------------------------------------------------------------



## CNC Machine Tools Series ..... P8-1

### Touch Probe Series for CNC Machine Tools (Summary ... P9-1)

With Wire	
	K3E •All Purpose ..... P9-5
	K3M •For Robots ..... P9-7
	K2A/K2C •For CNC lathe / Special purpose machines... P9-9/9-11
	E2A •For Cylindrical grinding machine ..... P9-13

### Tool Setter Series for CNC Machining Centers (Summary ..... P10-1)

<b>Small Type</b> 	TM26D ..... P10-5 • $\phi$ 20 Contact	<b>Cylindrical Type</b> 	T24E-120 ..... P10-8 • $\phi$ 20 Contact T24E-240 ..... P10-9 • $\phi$ 40 Contact T24E-260 ..... P10-10 • $\phi$ 60 Contact
<b>Square Type</b> 	T20-120 ..... P10-11 • $\phi$ 20 Contact Stationary contact type	<b>Horizontal Installation Type</b> 	T26K ..... P10-13 • $\phi$ 20 Contact
<b>Flat Type</b> 	P21 ..... P10-15 • $\phi$ 10 Contact Stationary contact type	<b>For Diameter Measurement</b> 	TD1 ..... P10-17 • $\phi$ 20 Contact

### Tool Setter Series for CNC Lathes (Summary ..... P11-1)

<b>Linear Type</b> 	H4A-001 ..... P11-3	<b>Linear Type</b> 	H4E ..... P11-5
-----------------------------------------------------------------------------------------------------------	---------------------	------------------------------------------------------------------------------------------------------------	-----------------

### Drill Bit Breakage Detection Sensor

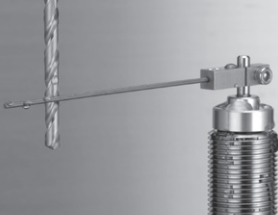
	<b>Pneumatic drive!</b> Outstanding resistance to coolant because there is no control motor. DFM3 ..... P12-1
-------------------------------------------------------------------------------------	---------------------------------------------------------------------------------------------------------------------

### References

- Terms of Warranty ..... P0-1
- Features and merits of High-precision positioning switches ..... P3-2
- Common warnings and Precautions for All-purpose High-Precision Switch Series ..... P7-1
- Common warnings and Precautions for CNC Machine Tools Series ..... P13-1
- Technical Guide ..... P14-1
- Alphabetical Index ..... P15-1
- Communication sheet ..... P15-3

# Selection by application

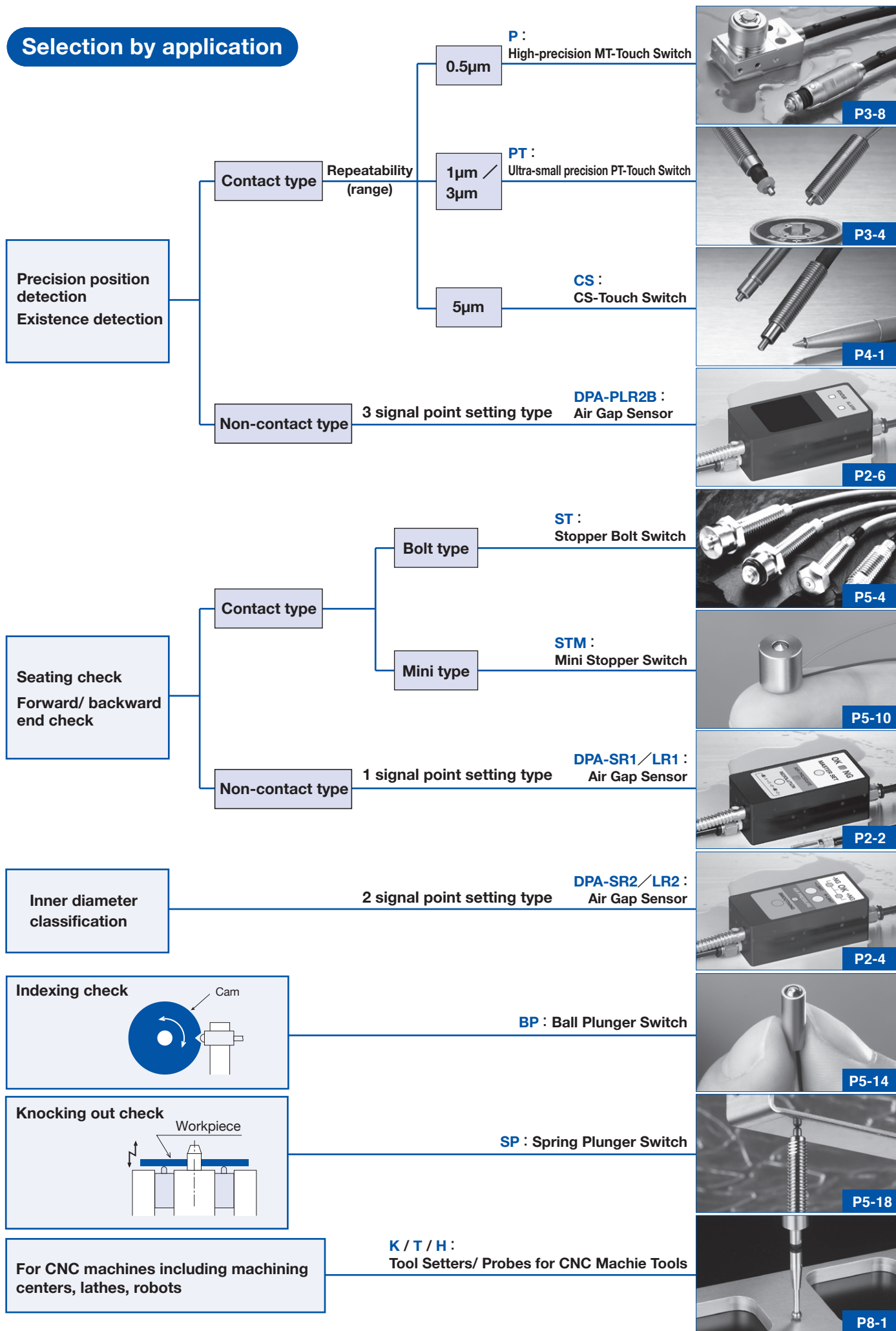

## Selection by functionality

### High-precision type



Repetitive accuracy of **0.5 μm** (range)  
**High-precision MT-Touch Switch** ..... P3-6



Repetitive accuracy of **1 μm / 3 μm** (range)  
**Ultra-small precision PT-Touch Switch** ..... P3-4

### Low contact force type



Contact force **0.1N**  
**Low contact force Switch CSF** ..... P6-2

### Long stroke type

Long stroke type is suitable when large clearance is required.



Stroke **10mm**  
**P10DLB / P12DLB** ..... P3-10  
**P10DHLTB** ..... P3-16



Stroke **5mm**  
**CSK** ..... P4-3

### Non-contact (pneumatic) type

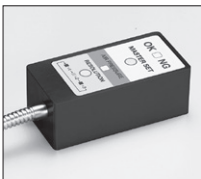

1 signal point setting type (OK, NG)  
 Detection distance 1-100μm  
**DPA-SR1** ..... P2-2  
 Detection distance 80-350μm  
**DPA-LR1** ..... P2-2

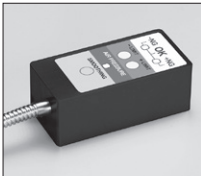

2 signal point setting type (+NG/OK/-NG)  
 Detection distance 1-100μm  
**DPA-SR2** ..... P2-4  
 Detection distance 80-350μm  
**DPA-LR2** ..... P2-4

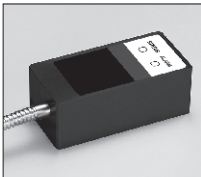

3 signal point setting type (4 classifications)  
 Detection distance 80-350μm  
**DPA-PLR2B** ..... P2-6

### Small size type



**M5/φ5 × 17mm**  
**Ultra-small precision PT-Touch Switch** ..... P3-4



**M5 / φ5**  
**CS-Touch Switch CSJ** ..... P4-3

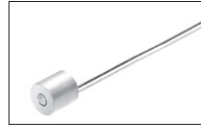

**φ8 × 8**  
**CS-Touch Switch CSM** ..... P4-13  
**Mini Stopper Switch STM** ..... P5-10

### Waterproof type (IP67)

A special rubber is applied to the boot for MT-Touch switch plunger type showing high resistance against alkaline and acid coolants. Optional boots protective covers can even handle cutting chips.



**High-precision MT-Touch Switch** ..... P3-6



**CS-Touch Switch**  
**CSP** ..... P4-3  
**CSHP** ..... P4-9  
**CSMP** ..... P4-13



**Stopper Bolt Switch STP** ..... P5-4

### Heat resistance type



Operating upper limit temperature **200°C**  
**Heat resistance Switch** ..... P6-4

### High-vacuum resistance type



Supports vacuum as high as **10<sup>-5</sup> Pa**.  
**High-vacuum resistance Switch** ..... P6-6

### Sensors for CNC machine tools ..... P8-1



Touch probes can be used for measuring workpiece dimensions, centering or positioning by installing in CNC machines such as lathes, machining centers, grinders, special-purpose machines or robots.

# AIR GAP SENSOR SERIES

## ■ 1 Signal Point Setting Type Short/Long Range Detection



## ■ 2 Signal Point Setting Type Short/Long Range Detection



## ■ 3 Signal Point Setting Type Long Range Detection



## 1 Signal Point Setting Type (Short/Long Range Detection)

- OK/NG classification
- One-push master setting
- Output mode: NO
- IP67 protective structure

DPA-SR1 ..... P2-2

DPA-LR1 ..... P2-2

---

## 2 Signal Point Setting Type (Short/Long Range Detection)

- +NG/OK/-NG 3 classifications
- One-push master setting/ Setting by external input
- Output mode: NO
- IP67 protective structure

DPA-LR2 ..... P2-4

DPA-SR2 ..... P2-4

---

## 3 Signal Point Setting Type (Long Range Detection)

- Setting 3 signal points of master • 4 classifications
- Setting by external input
- Output mode: NC
- IP67 protective structure

DPA-PLR2B ..... P2-6

---



## DPA-SR1/LR1

## 1 Signal Point Setting Type

Short/Long range detection



\* Photo shows the optional protective tube attached.

### • 1–100µm Short Range Detection Type

#### DPA-SR1

The gaps caused by cutting chips put between the workpiece and the jig can be detected reliably with  $\pm 0.5\mu\text{m}$  to  $\pm 1\mu\text{m}$  repeatability.

### • 80–350µm Long Range Detection Type

#### DPA-LR1

Reliably detects the gaps of 80 to 350µm with  $\pm 1\mu\text{m}$  to  $\pm 5\mu\text{m}$  repeatability. Best suited for seating confirmation of big workpieces or workpieces with rough surface.

## Specification

Product name	DPA-SR1 (Short range detection type)	DPA-LR1 (Long range detection type)
Detection range	1–100µm (When using a recommended nozzle)	80–350µm (When using a recommended nozzle)
Signal point	Configurable by master set button The signal point values are saved even when the power is turned off.	
Repeatability	$\pm 0.5\mu\text{m}$ : Detection range 1–60µm $\pm 1\mu\text{m}$ : Detection range 60–100µm  <b>Air Pressure change : within <math>\pm 1\%</math></b> Tube length 1.5m/When using a recommended nozzle	$\pm 1\mu\text{m}$ : Detection range 80–150µm $\pm 3\mu\text{m}$ : Detection range 150–250µm $\pm 5\mu\text{m}$ : Detection range 250–350µm  <b>Air Pressure change : within <math>\pm 1\%</math></b> Tube length 1.5m/When using a recommended nozzle
Response speed	0.8 seconds (Tube length 1.5m/Time between the air pressure supply and the signal output of the sensor.)	
Electrical response speed	80ms	
Protective structure	IP67	
Setting pressure	0.15–0.2MPa	
Pipe diameter	O.D. $\phi 6$ X I.D. $\phi 4$ tube	
Fluid	Dry air (filtered to 5µm)	
Consumption flow rate	9ℓ/min (max)	24ℓ/min (max)
Operating temperature range	0°C–60°C (no condensation)	
Cable (Refer to P7-5)	Standard length 3m Oil resistance $\phi 5/4$ cores AWG 30	
Power supply voltage	DC24V $\pm 10\%$ Current consumption : less than 100mA	
Output specification	Photo MOS output (Non-voltage floating output) DC30V (max) 100mA (max)	

## Circuit diagram

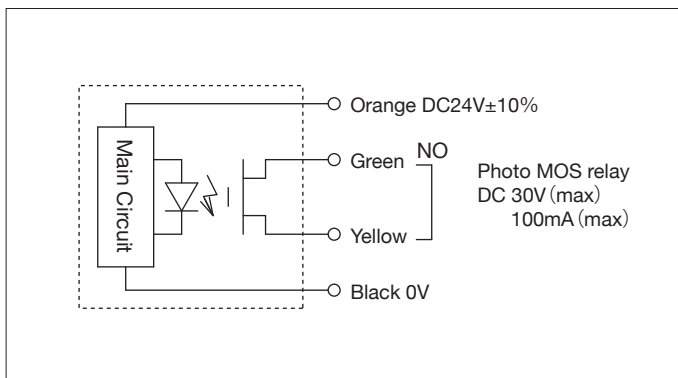

✓  $\pm 0.5\mu\text{m}$  Repeatability.  
Reliably detects 10µm gap caused by cutting chips and stops machining automatically.

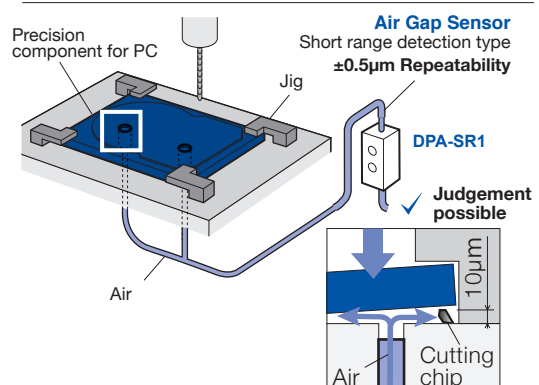



## Outer dimension

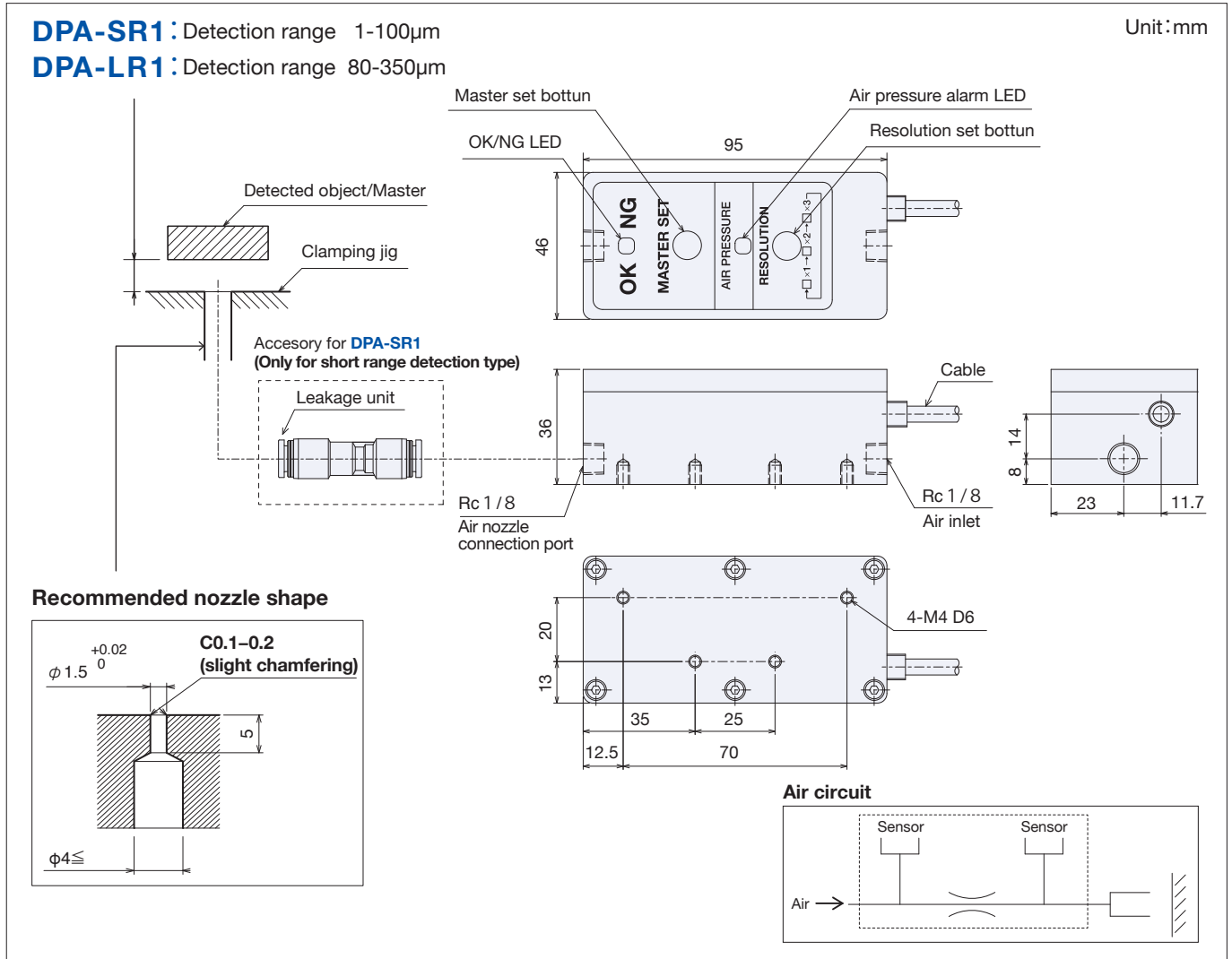

## Options

Product No.	Tube length	Cable protection
<b>DPA-SR1</b> <b>DPA-LR1</b>	Blank : 3m	Blank : No cable protection <b>P2</b> : Protective tube 2m

► e.g.) DPA-SR1-P2

### Precautions before using the product

Following parts are not included.  
It is necessary for the customer to prepare.

- Precision regulator
- Air filter
- Tube

Please refer to P2-9 for details.

### Protective tube for cable protection

**Dimension** : outer diameter  $\phi 9$   
**Minimum bending radius** : 25mm

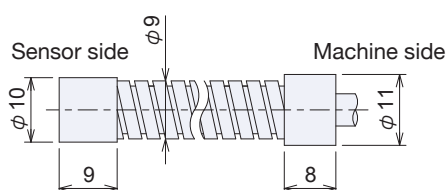

Sensor side is screwed in and metal ring is attached to machine side.

### Handling instruction

- 1) Because protective tube is not flexible, clamp it to fix so as not apply excessive force to the sensor.
- 2) When binding it up and clamp with other cables, make sure not to apply excessive force to the attachment end.
- 3) Cables are not waterproof.

## DPA-SR2/LR2

## 2 Signal Point Setting Type

Short/Long range detection



\* Photo shows the optional protective tube attached.

### • 3 Classifications (-NG, OK, +NG)

Displays results and outputs signals based on 3 classifications (-NG, OK, +NG) by setting upper and lower limit points.

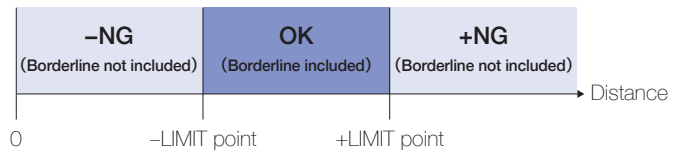

### Specification

Product name	DPA-SR2 (Short range detection type)	DPA-LR2 (Long range detection type)
Detection range	1–100µm (When using a recommended nozzle)	80–350µm (When using a recommended nozzle)
Signal point	Set by +LIMIT SET button, -LIMIT SET button, +LIMIT SET input and -LIMIT SET input The signal point values are saved even when the power is turned off.	
Repeatability	±0.5µm : Detection range 1–60µm ±1µm : Detection range 60–100µm  <b>Air pressure change : within ±1%</b> Tube length 1.5m/When using a recommended nozzle	±1µm : Detection range 80–150µm ±3µm : Detection range 150–250µm ±5µm : Detection range 250–350µm  <b>Air pressure change : within ±1%</b> Tube length 1.5m/When using a recommended nozzle
Response speed	0.8 seconds (Tube length 1.5m/ Time between the air pressure supply and the signal output of the sensor.)	
Electrical response speed	10ms	
Protective structure	IP67	
Setting pressure	0.15–0.2MPa	
Pipe diameter	O.D. φ6 X I.D. φ4 tube	
Fluid	Dry air (filtered to 5µm)	
Consumption flow rate	9ℓ/min (max)	24ℓ/min (max)
Operating temperature range	0°C–60°C (no condensation)	
Cable (Refer to P7-5)	Standard length 3m Oil resistance φ5.5/16 cores AWG 28	
Power supply voltage	DC24V±10% Current consumption : less than 100mA	
Input specification	Photocoupler input DC24V±10%	
Output specification	Photocoupler output (Non-voltage floating output) DC24V±10% 20mA (max) Low level output voltage : less than 1.5V (at 15mA)	

### Circuit diagram

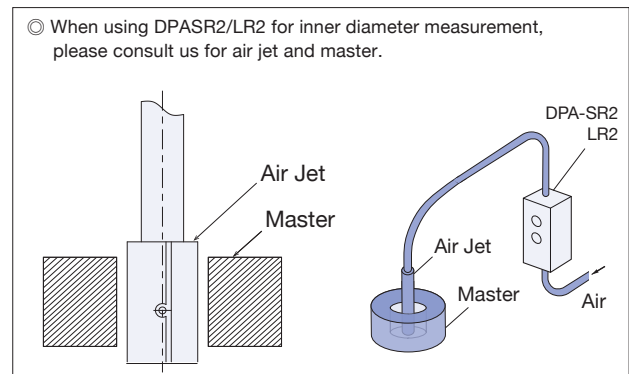
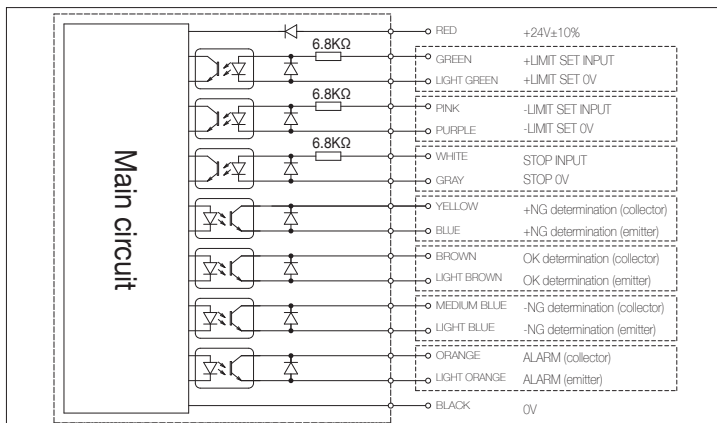

## Outer dimension

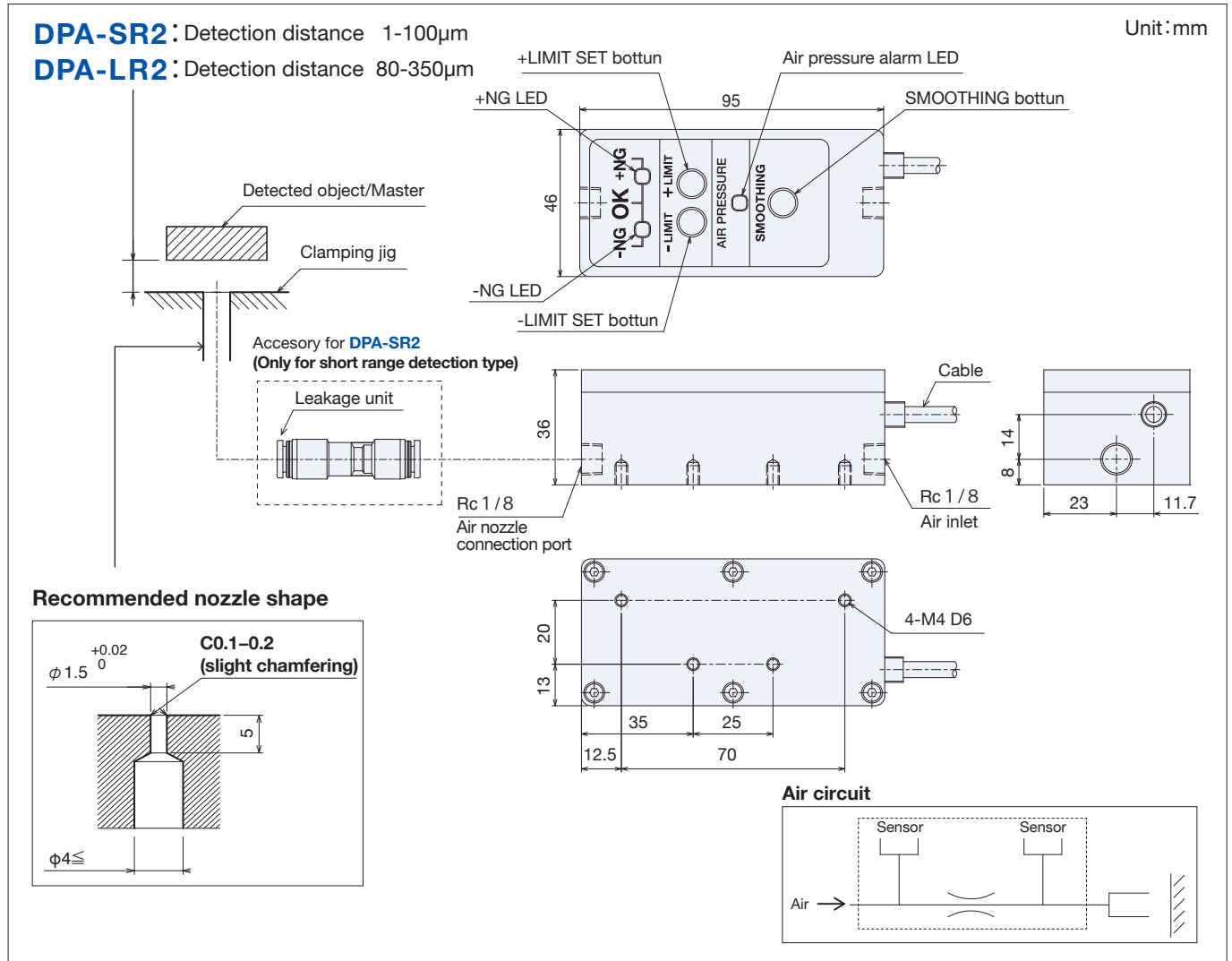

## Options

Product No.	Tube length	Cable protection
<b>DPA-SR2</b> <b>DPA-LR2</b>	Blank : 3m	Blank : No cable protection <b>P2</b> : Protective tube 2m

► e.g.) DPA-SR2-P2

### Precautions before using the product

Following parts are not included. It is necessary for the customer to prepare.

- Precision regulator
- Air filter
- Tube

Please refer to P2-9 for details.

### Protective tube for cable protection

**Dimension** : outer diameter  $\phi 9$   
**Minimum bending radius** : 25mm

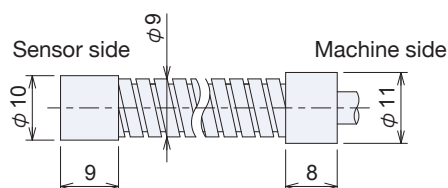

Sensor side is screwed in and metal ring is attached to machine side.

### Handling instruction

- 1) Because protective tube is not flexible, clamp it to fix so as not apply excessive force to the sensor.
- 2) When binding it up and clamp with other cables, make sure not to apply excessive force to the attachment end.
- 3) Cables are not waterproof.

# Air Gap Sensor

# DPA-PLR2B

## Air Gap Sensor series

### 3 Signal Point Setting Type Long range detection

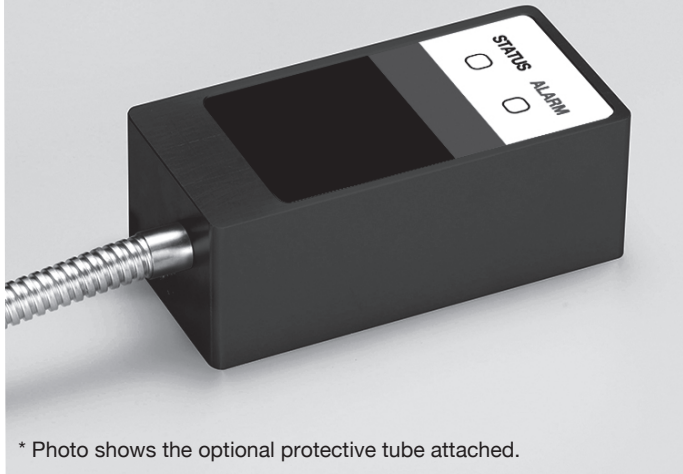

\* Photo shows the optional protective tube attached.

- This sensor will judge the current value, in comparison with master setting points.
- The master values, composed of masters #1, #2, and #3, are displayed and output.

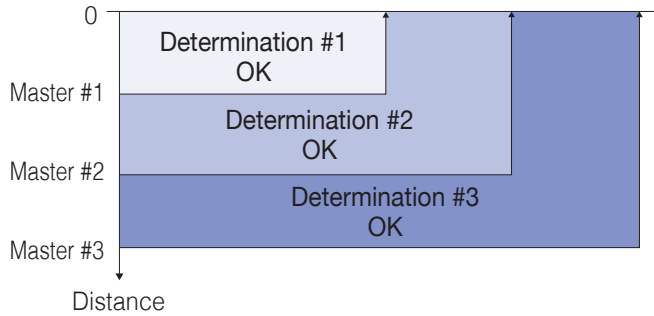

### Specification

Product name	<b>DPA-PLR2B</b>
Detection range	80–350µm (When using a recommended nozzle)
Signal point	The arbitrary 3 points can be set
Repeatability	±1µm : Detection range 80-150µm ±3µm : Detection range 150–250µm ±5µm : Detection range 250-350µm  <b>Air pressure change : within ±1%</b> Tube length 1.5m/When using a recommended nozzle
Response speed	0.8 seconds (Tube length 1.5m/ Time between the air pressure supply and the signal output of the sensor)
Electrical response speed	10ms
Protective structure	IP67

Setting pressure	0.15–0.2MPa
Pipe diameter	O.D. φ6 X I.D. φ4 tube
Fluid	Dry air (filtered to 5µm)
Consumption flow rate	24ℓ/min (max)
Operating temperature	0°C–60°C (no condensation)
Cable (Refer to P7-5)	Standard length 3m Oil resistance φ5.5/16 cores AWG 28
Power supply voltage	DC24V±10%
Consumption current	Less than 100mA
Input specification	Photocoupler input DC24V±10%
Output specification	Photocoupler output (Non-voltage floating output) DC24V±10% 20mA (max), Low level output voltage : less than 1.5V (at 15mA)

### Circuit diagram

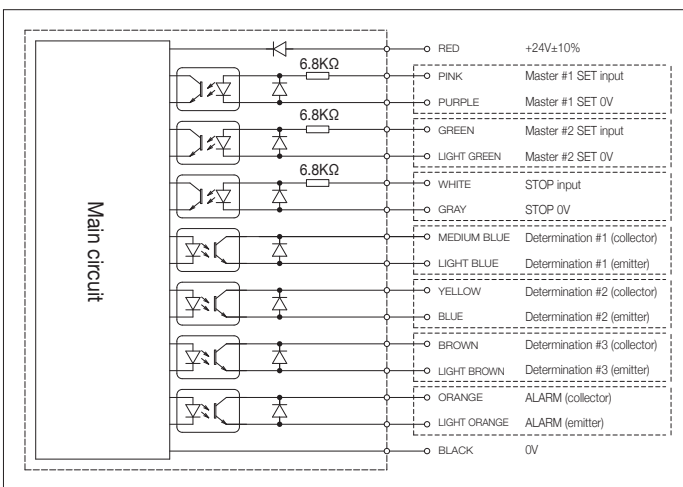

### 3 Signal Point Setting Example

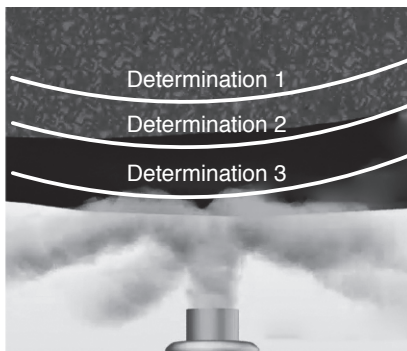

**Since 3 determination signal points can be output, it can be used for various applications.**

- The signals can be divided into the deceleration signal (Determination 1), measurement signal (Determination 2), and stop signal (Determination 3).
- Usage with 3 types of grindstones with different grits is possible.

## Outer dimension

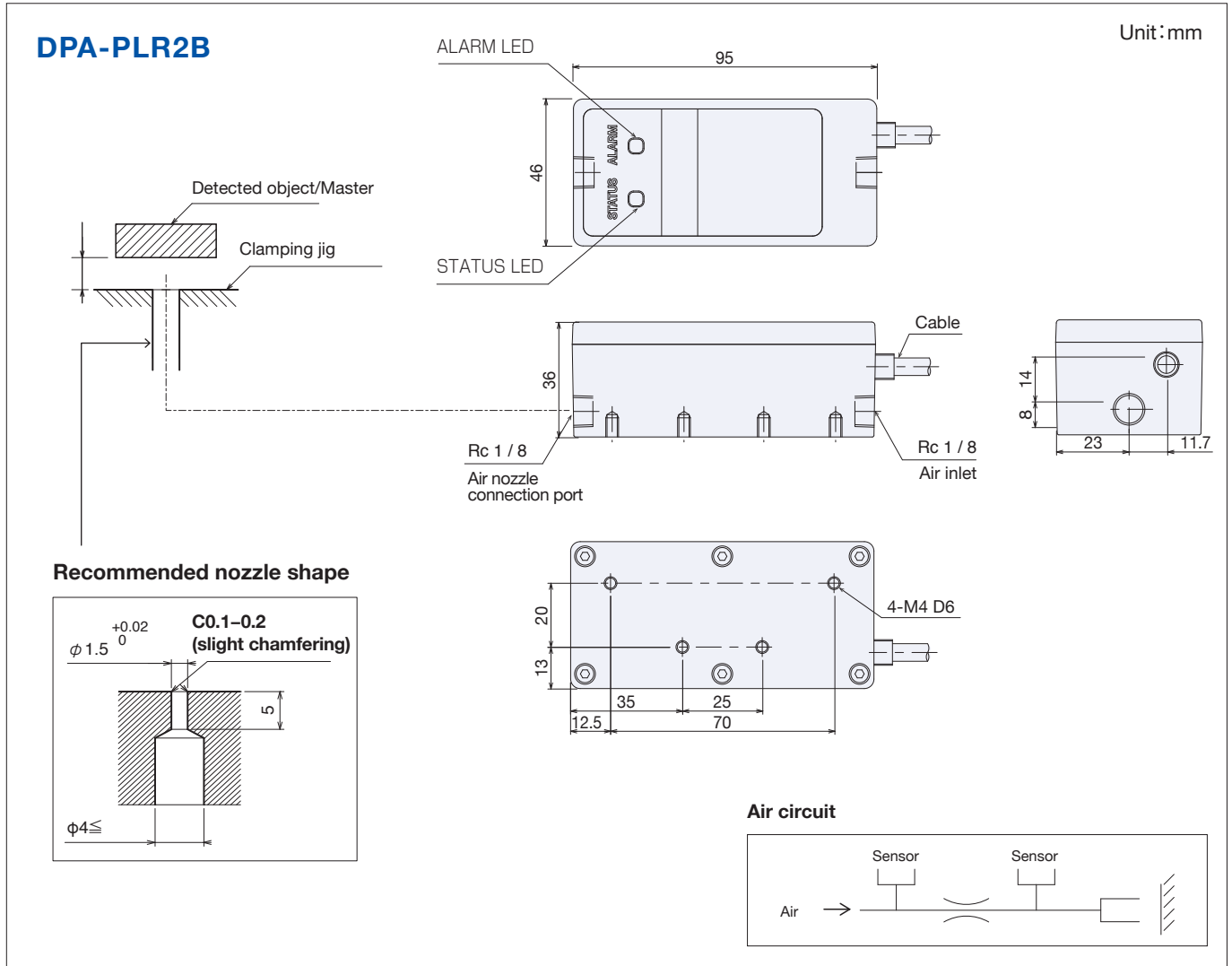

## Options

Product No.	Tube length	Cable protection
<b>DPA-PLR2B</b>	Blank : 3m	Blank : No cable protection <b>P2</b> : Protective tube 2m

▶ e.g.) DPA-PLR2B

### Precautions before using the product

Following parts are not included.  
It is necessary for the customer to prepare.

- Precision regulator
- Air filter
- Tube

Please refer to P2-9 for details.

### Protective tube for cable protection

**Dimension** : outer diameter  $\phi 9$   
**Minimum bending radius** : 25mm

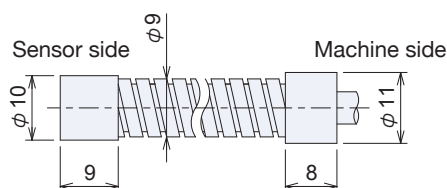

Sensor side is screwed in and metal ring is attached to machine side.

### Handling instruction

- 1) Because protective tube is not flexible, clamp it to fix so as not apply excessive force to the sensor.
- 2) When binding it up and clamp with other cables, make sure not to apply excessive force to the attachment end.
- 3) Cables are not waterproof.

## Air sensors

A sensor that detects the distance by the pressure (back pressure) changes and outputs electric signals to the control system.

### Air Gap Sensor detecting circuit

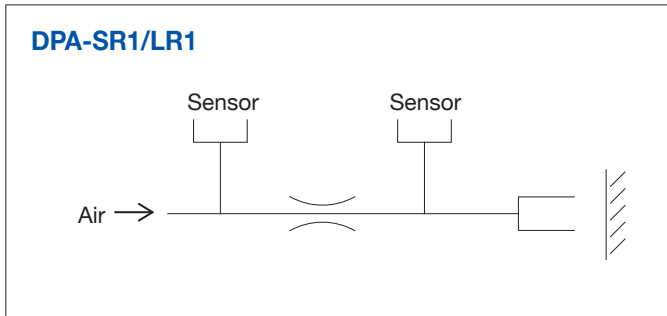

DPA-SR1 / LR1 gives a detection gap to the detection air nozzle, and records the pressure value by pressing the **Master Set Button**.

The differential pressure by detection gap is detected by the internal pressure sensor.

### Repetitive accuracy

Indicates the repeatability of the output operating point of the sensor when the pressure is changed by the detection gap at 20°C.

\*Specifications on this catalog apply to conditions where one nozzle is used per body.

When using multiple nozzles or using a nozzle which diameter is different from the recommended nozzle shape, repeatability will be deteriorated, make appropriate judgments upon confirmation of use with the actual device.

### Master for setting

The master for setting is necessary in order to set the signal point correctly.

If the surface roughness of the master is bad or the signal point is set while the master is floating from the seating surface, there may be variations in the set value, so use a master with a good surface roughness, and make sure that it is fixed firmly on the seating surface.



## Regulator (reducing valve)

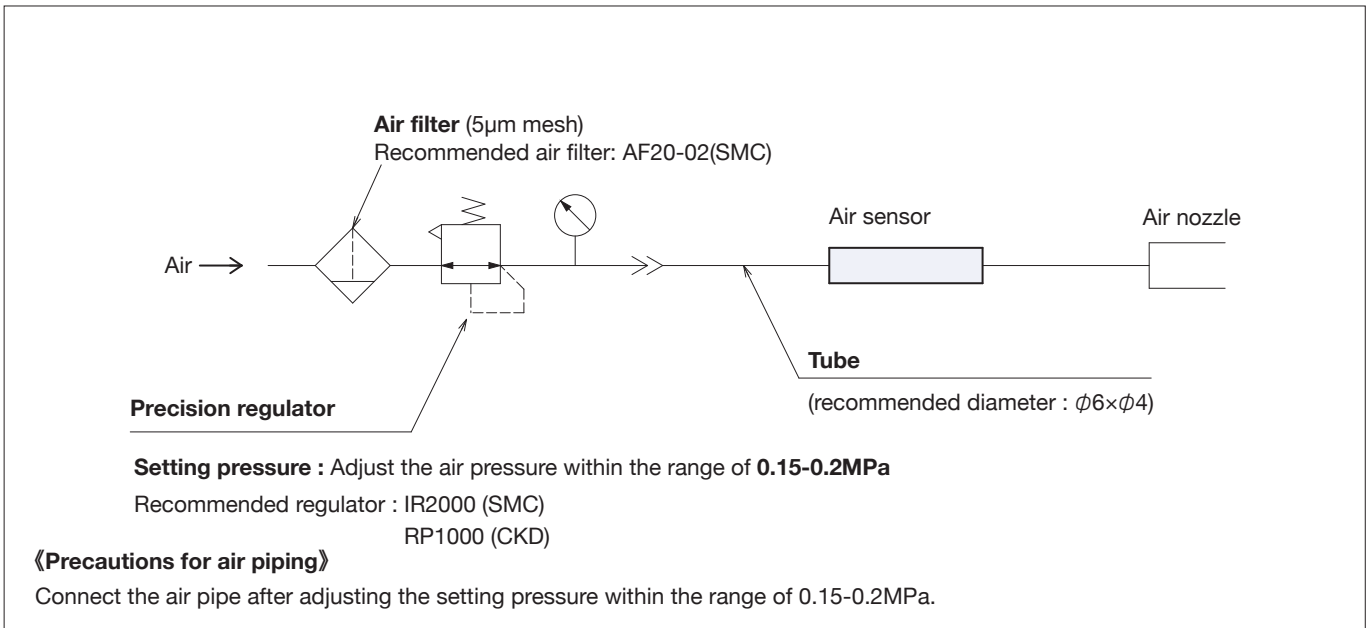

## Precision regulator (reducing valve)

It can be used to adjust the air supplied from the compressor to the appropriate pressure according to the specifications of the air equipment used.

The "precision regulator ( $\pm 0.5\%$  level)" needs to be provided on the air supply side of the Air gap sensor to reduce the pressure fluctuation.

## Air filter

- Prevents troubles such as malfunctions that are caused by dust and moisture entering into the regulator or Air Gap Sensor.
- As the moisture separation rate (removal rate) is about 30 to 90%, the use of dry air is desirable.
- There is a drainage valve at the lower end of the filter, which needs to be opened regularly in order to discharge.

## Recommended nozzle shape

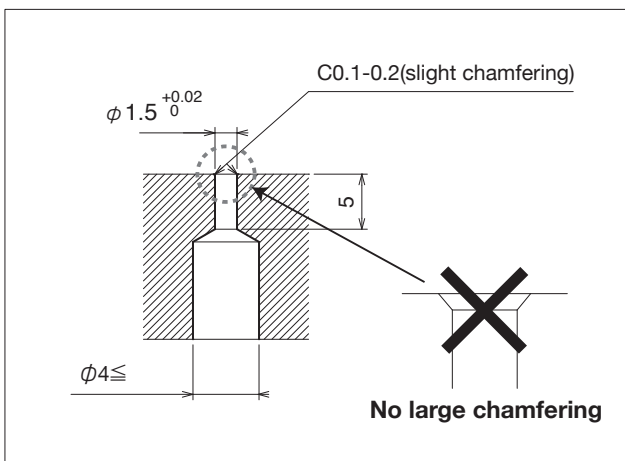

## Precautions for piping

- When installing air gap sensor, make sure to place it above the nozzle to prevent backflow of coolant.
- The shorter the air piping tube, the faster the response speed.
- For the piping from the body to the detection nozzle, do not use devices or joints which will lead to air leaks or resistance.
- When supplying air of 0.3MPa or higher to the device, there is a risk of sensor damage.  
Connect the air pipe after adjusting the setting pressure within the range of **0.15 to 0.2 MPa**.

# High-precision POSITIONING SWITCH SERIES

## ■ Ultra-small precision PT-Touch Switch

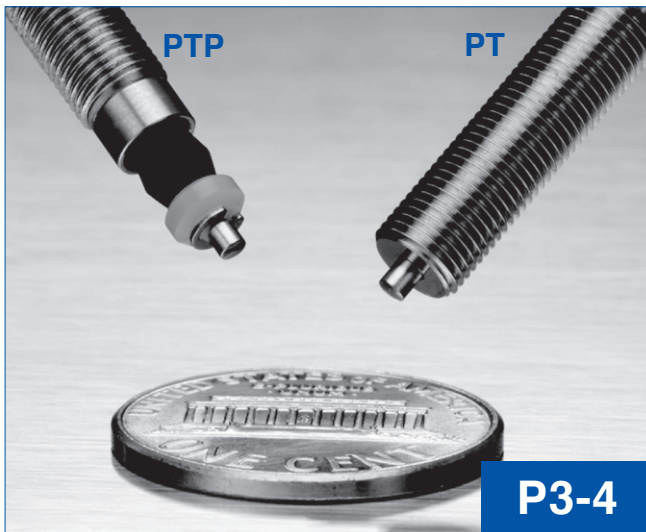

## ■ High-precision MT-Touch Switch



## ■ CS-Touch Switch



## Ultra-small precision PT-Touch Switch

■ 1 μm (range) in repetitive accuracy

■ M5×17mm

· Straight touch type (Metal bearing) **PT** ..... P3-4

## High-precision MT-Touch Switch

■ 0.5 μm (range) in repetitive accuracy

■ IP67 protective structure, high resistance to harsh environment

· Straight touch type (Metal bearing) **P08 / P10 / P12** .. P3-10

· Sliding and angled touch type (Ball bearing) **P10DH** ..... P3-16

· Straight touch, flat type (Metal bearing) **P11** ..... P3-22

## CS-Touch Switch

■ 5 μm (range) in repetitive accuracy

■ Compact design (M5-)

■ Wide variations

· Straight touch type (Metal bearing) **CS / CSJ / CSS / CSK / CSP** .. P4-3

· Sliding and angled touch type (Linear bushing bearing) Waterproof type **CSHP** ..... P4-9

· Sliding and angled touch type (Linear bushing bearing) **CSH** ..... P4-11

· Straight touch, short type (Metal bearing) **CSM** ..... P4-13

# Features and merits of High-precision positioning switches

## 1. High repetitive accuracy

Improvement in production efficiency and quality management.

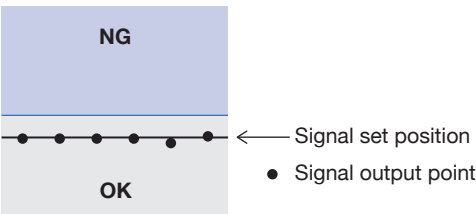
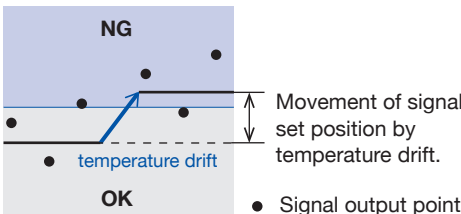
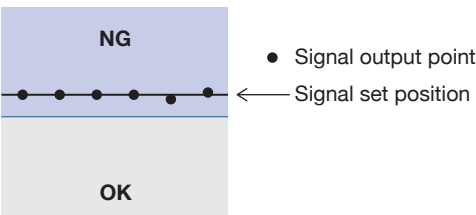
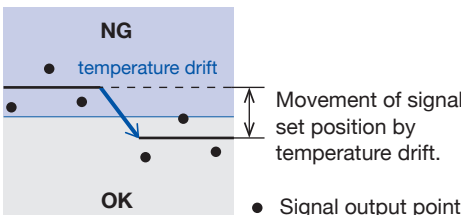
	High-precision positioning switches by Metrol	Existence detection sensors
	<ul style="list-style-type: none"> <li>- Small signal point adjustment variance</li> <li>- Possible to determine OK/NG even for detected object with narrow allowable tolerance.</li> <li>- Precision mechanical type without any electronic circuitry. Results in no movement differential of signal set position caused by temperature drift from its temperature characteristics.</li> </ul>	<ul style="list-style-type: none"> <li>- Signal point adjustment variance is large.</li> <li>- Unable to detect OK/NG objects where allowable tolerance range is small.</li> <li>- Signal set points are moved by temperature drift.</li> </ul>
Set signal position at limit value of OK range	 <p>Can be set to the extreme of limit value ⇒ <b>Improvement in both production efficiency and quality management.</b></p>	 <p>Determines NG item as OK item ⇒ <b>Decrease in production efficiency (yield rate)</b></p>
Set signal position at limit value of NG range	 <p>Can be set to the extreme of limit value ⇒ <b>Improvement in both production efficiency and quality management.</b></p>	 <p>Determines NG item as OK item ⇒ <b>Manufacture of defective item</b></p>

## 2. No movement differential

Can detect micro movement of workpiece.

### ✓ Workpiece seating check using High-precision Positioning Switches

No movement differential between set signal position and signal return position makes it possible to **detect micro movement of workpiece.**

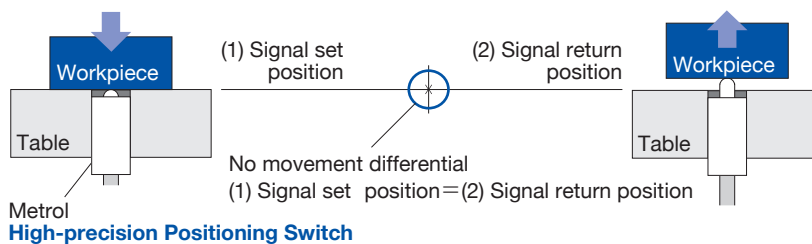

#### What is movement differential?

The difference in distance between the point where the sensor detects the detected object and activates and the point where it returns. (Distance from the signal set position to signal return position)

### ✗ Workpiece seating check using proximity sensor

**Micro movement of workpiece cannot be detected** as there is a movement differential between the signal set position and signal return position.

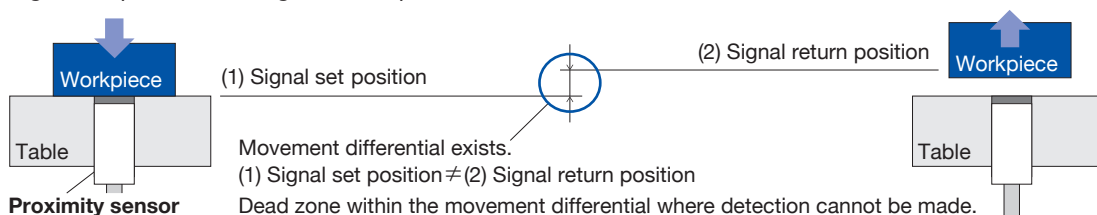

### 3. Robust under harsh environment

Stable detection of detected object without being affected by external environment such as material, shape, temperature and others.

#### ✗ Workpiece detection using a proximity and light sensor

Signal point varies with the change in external environment, necessitating frequent master alignment.

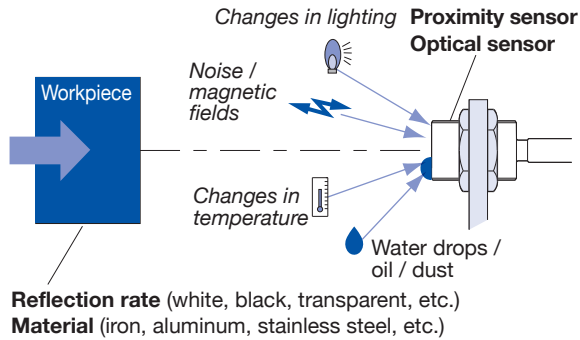

#### ✓ Workpiece detection using a High-precision Positioning Switch

Contact type switch makes it difficult to be affected by external environment making it usable as origin and reference points in NC machines.

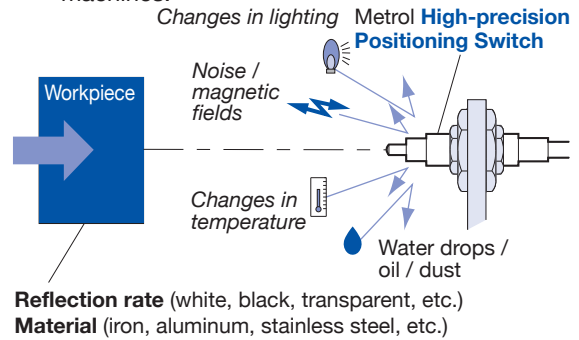

### 4. No mutual interference

Can be used for narrow pitches.

#### ✗ Detection of workpiece with proximity sensors

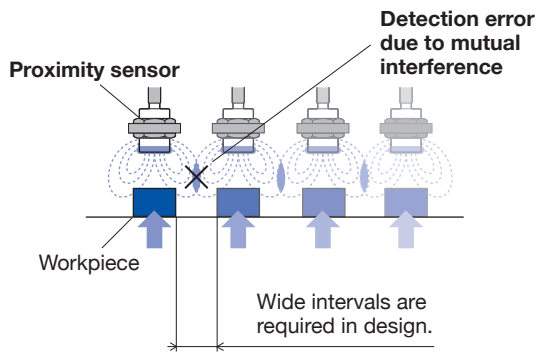

#### ✓ Detection of workpiece with High-precision Positioning Switches

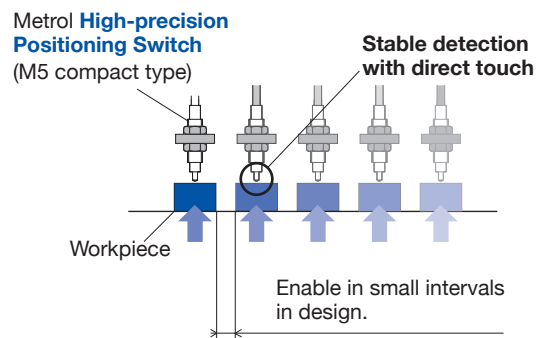

### 5. No need to manufacture intermediate actuator for stable detection.

Results in miniaturization of machine and equipment and in cost reduction.

#### ✗ Detection of screws in deep holes with a proximity sensor

Requires a mediating actuator for stable detection, making the mechanism complex.

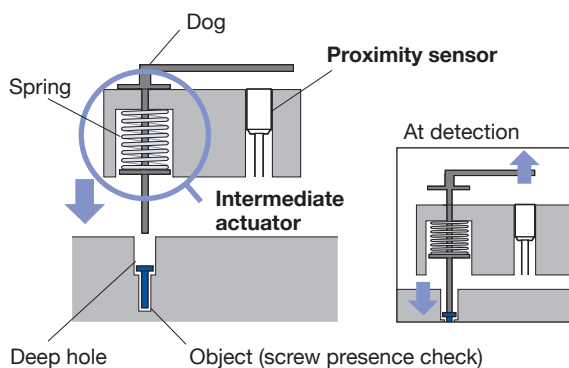

#### ✓ Detection of screws in deep holes with High-precision Positioning Switches

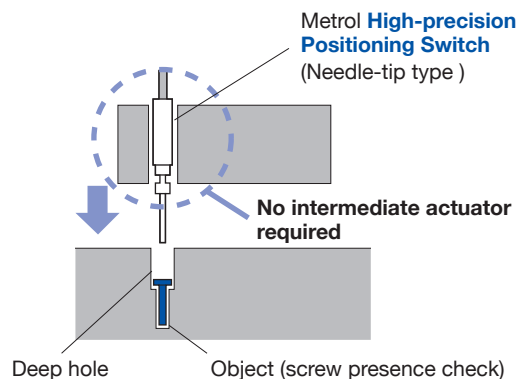

# PT

1 signal plunger type  
**Straight touch type (Metal bearing)**

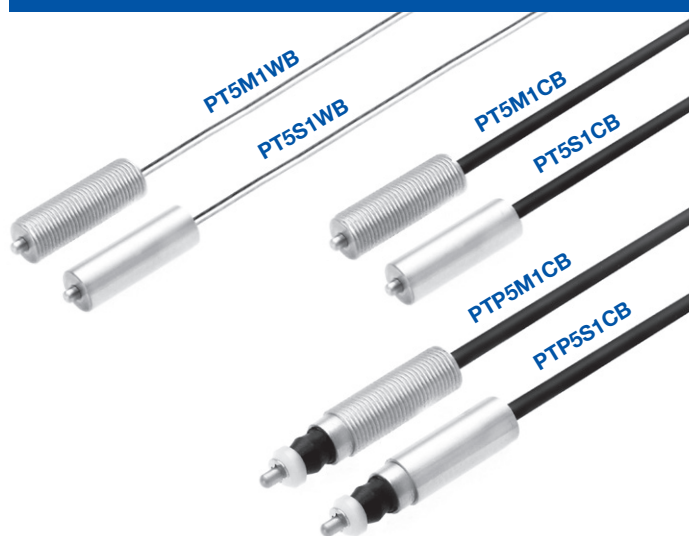

### Features

- M5 (or  $\phi 5$ ) x 17mm slim switches
- 1 $\mu$ m / 3 $\mu$ m in repetitive accuracy (user selectable)

### 《Application》

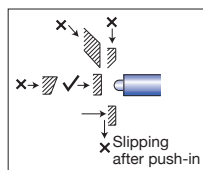

### Standard specification

Repeatability : 1 $\mu$ m type

Unit : mm

Repeatability <sup>1</sup>	Protective structure	Product name	Output mode	Pretravel	Contact force	Cable	Size	With LED
0.001mm(range) (Both ON $\leftrightarrow$ OFF)	IP40	PT5M1WB	B : NC	0 <sup>2</sup>	0.5N	Core-wire cable	M5x0.5	
		PT5S1WB					$\phi 5$	
		PT5M1CB				M5x0.5	PT5M1CB -L	
		PT5S1CB				$\phi 5$	PT5S1CB -L	
	IP67	PTP5M1CB	M5x0.5	PTP5M1CB -L				
		PTP5S1CB	$\phi 5$	PTP5S1CB -L				
IP40		PT5M1WA	A : NO	About 0.3	0.5N	Core-wire cable	M5x0.5	
		PT5S1WA	$\phi 5$					

Repeatability : 3 $\mu$ m type

Repeatability <sup>1</sup>	Protective structure	Product name	Output mode	Pretravel	Contact force	Cable	Size	With LED
0.003mm(range) (Both ON $\leftrightarrow$ OFF)	IP40	PT5M3WB	B : NC	0 <sup>2</sup>	0.5N	Core-wire cable	M5x0.5	
		PT5S3WB					$\phi 5$	
		PT5M3CB				M5x0.5	PT5M3CB -L	
		PT5S3CB				$\phi 5$	PT5S3CB -L	
	IP67	PTP5M3CB	M5x0.5	PTP5M3CB -L				
		PTP5S3CB	$\phi 5$	PTP5S3CB -L				
IP40		PT5M3WA	A : NO	About 0.3	0.5N	Core-wire cable	M5x0.5	
		PT5S3WA	$\phi 5$					

\*1 At operating speed 50-200mm/min (operating speed slower than 10mm/min is not recommended).

-L : LED indicator

\*2 Adjust the installed location of the switch by the signal switching point.

(120mm from the switch)

### Common specification

unit:mm

Switch structure	Dry contact
Movement differential	0
Contact life time	3 million (No bungle caused by vibration and use under contacting rating)
Stroke	1.5
Contact material	SUS HRC45
Case material	SUS303

Cable (Refer to P7-5)	Core-wire cable : 0.5m (x 2) Oil-resistant $\phi 0.6$ Tensile strength 15N
	Cabtyre cable : 2m Oil-resistant $\phi 2.8/2$ cores Tensile strength 30N Minimum bending R7
Operating temperature range	0°C-80°C (ice-free)
Temperature drift	0 (because of no amplifier)
Oscillation	10-55Hz Total amplitude 1.5 for X, Y, Z each direction
Impact	300m/s <sup>2</sup> for X,Y,Z each direction
Contact rating (Refer to P14-3)	DC5V-DC24V Steady current : 10mA or less (rush current : 20mA or less) <b>When using the switch with LED, limit the current below 10mA.</b>
Standard accessory	Two fixing nuts for threaded type

### ◎The following options are available

- Transistor output (refer to P7-3)
- Shape of contacting part
- Reverse connect protection
- Level conversion
- Output current is increased to 100mA
- LED indicator



Outer dimension

Output mode B : NC

For LED indicator (-L), refer to the next page.

Core-wire cable

**PT5M1WB** (B : NC)  
**PT5M3WB** (B : NC)

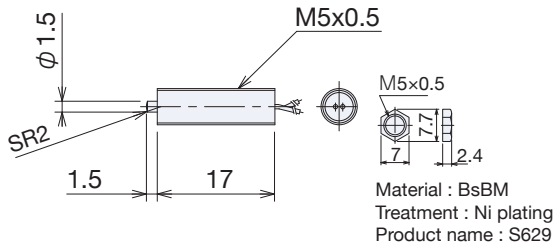

**PT5S1WB** (B : NC)  
**PT5S3WB** (B : NC)

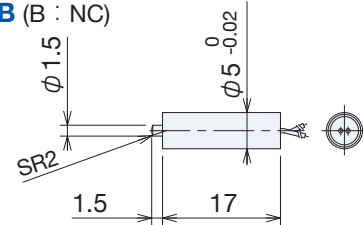

Cable type

**PT5M1CB** (B : NC)  
**PT5M3CB** (B : NC)

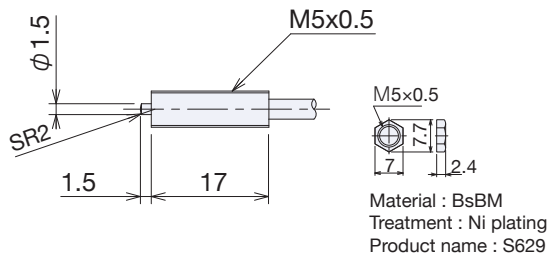

**PT5S1CB** (B : NC)  
**PT5S3CB** (B : NC)

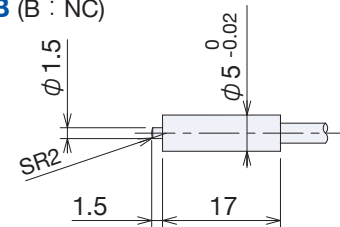

Waterproof type (IP67)<sup>\*3</sup>

**PTP5M1CB** (B : NC)  
**PTP5M3CB** (B : NC)

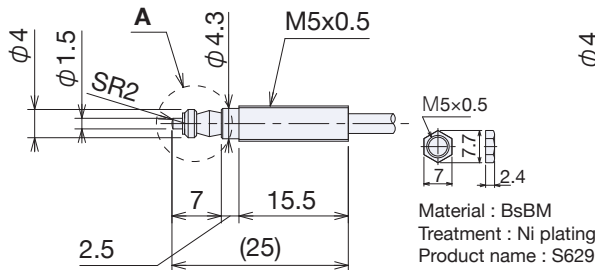

**PTP5S1CB** (B : NC)  
**PTP5S3CB** (B : NC)

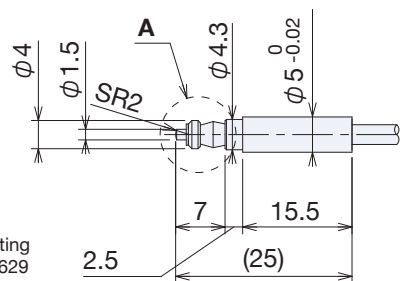

Details of part A

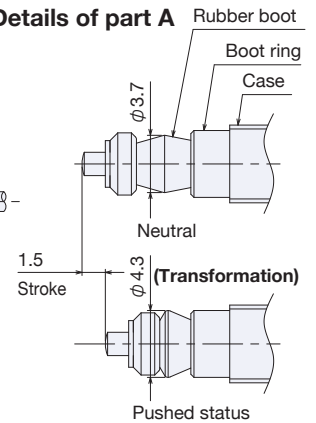

\*3 Not suitable for use in harsh environment such as where there are scattering of coolant.

The use of **High-precision MT-Touch Switch P085DB/P08SB** (P3-10) is recommended in that case.

Output mode A : NO

Core-wire cable

**PT5M1WA** (A : NO)  
**PT5M3WA** (A : NO)

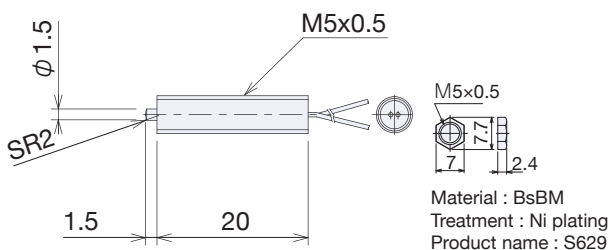

**PT5S1WA** (A : NO)  
**PT5S3WA** (A : NO)

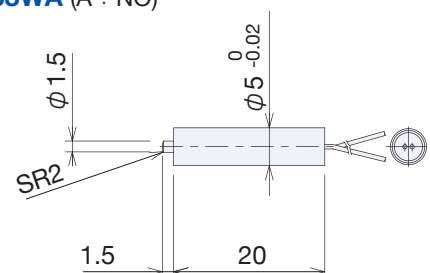

Ultra-small precision PT-Touch Switch

Options

Output mode B : NC

Product name	Transistor output	Shape of contacting part	LED Indicator
<b>Core-wire cable</b> PT5M1WB PT5S1WB PT5M3WB PT5S3WB  <b>Cabtyre cable</b> PT5M1CB PT5S1CB PT5M3CB PT5S3CB PTP5M1CB PTP5S1CB PTP5M3CB PTP5S3CB	<b>Blank :</b> Not required  <b>Only applicable for cabtyre cables</b> TNA TNB TPA TPB (refer to P7-3)	<b>Blank :</b> $\phi$ 1.5 plunger SR2  <b>Only applicable for PTP</b> <b>B :</b> $\phi$ 3 flat SUS Hardened	<b>Blank :</b> Not required  <b>Only applicable for cabtyre cables</b> <b>L :</b> 120mm from the switch

**B :  $\phi$ 3 flat**

**L : Tubular type**

- ▶ e.g.) PT5M1CB-L
- ▶ Transistor output e.g.) PT5M1CBTNA-L

Output mode A : NO

Product name	LED indicator
PT5M1WA PT5S1WA PT5M3WA PT5S3WA	Not available

- ▶ e.g.) PT5M1WA

How to use

Make contact with detected objects at right angle (within deflection angle  $\pm 3^\circ$ ).

If there is a possibility to press the plunger to the stroke end, install a stopper separately to prevent the malfunction.

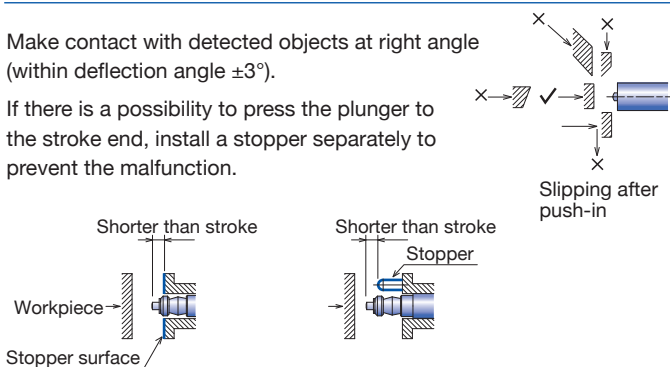

Circuit diagram

without LED	with LED
Normally closed (NC) 	Normally closed (NC) 
Normally Open (NO) 	

For electrical specification / circuit diagram (refer to P7-2)

**When using the switch with LED, limit the current below 10mA.**  
(Refer to P14-3 "Confirmation of switch operation")

Tightning torque for case screws and nuts

	Screw / Nut	Tightning torque
PT-Touch Switch	M5x0.5	1N·m

A series of horizontal dashed lines for writing notes.

# High-precision MT-TOUCH SWITCH

Selection by how to touch the objects

### Straight touch

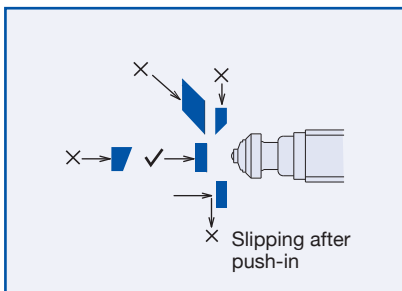

- Size: M8 / M10×0.5
- It is easy to adjust the set position thanks to fine thread.



- Size:  $\phi 8$  /  $\phi 10$
- With split clamp, position adjustment can be accurately done.



- No need of brackets



- Flat type which does not take up a large space.
- Suitable as a toolsetter

### Sliding and angled touch

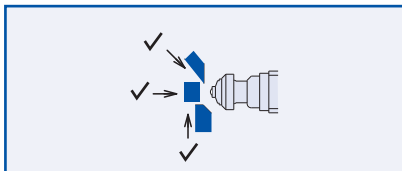

- Ball bearing type

## Merits of High-precision MT-Touch Switch

### ■ Small variance in operating point

Repetitive accuracy of 0.5 μm / 2 μm (range)

Can be used as origin and reference points in CNC machine tools.

Wrong decision and short time breakdowns due to wrong signals can be reduced.

### ■ Can be used in harsh environment

Tightly sealed water-resistant structure switch corresponding to IP67. (Except for P10MC)

### ■ No movement differential

Minute displacement can be continuously detected.



### ■ No temperature drift

No signal point drift due to the voltage of the power supply or self-generation.

### ■ Low current, low voltage switch that has a long life (3 million cycles) when used within the rated range.

## Product list

unit:mm

	Standard product name	Output mode	Protective structure	Size	Page
<b>Metal bearing</b> Threaded type / Non-threaded type 	P085DB	B : Normally close	IP 67	M8×0.5	<b>P3-10</b>
	P08SB			φ8	
	P10DA / P10DB	A : Normally open		M10×0.5	
	P10SA / P10SB	B : Normally close		φ10	
	P10DLB	B : Normally close		M10×0.5	
Square type 	P12DA / P12DB	A : Normally open	IP 67	2-M4	<b>P3-16</b>
	P12DLB	B : Normally close			
		B : Normally close			
<b>Ball bearing type</b> Threaded type 	P10DHA / P10DHB	A : Normally open	IP 67	M14×0.5	<b>P3-16</b>
	P10SHA / P10SHB	B : Normally close		φ14	
	P10DHLTB	B : Normally close		M14×0.5	

### Flat type

<b>Metal bearing</b> 	P11DDB / P11DMB	B : Normally close	IP 67	2-M4 /2-φ4.6	<b>P3-22</b>
	P11EDB / P11EMB				

## P08 / P10 / P12

1 signal plunger type  
**Straight touch type (Metal bearing)**

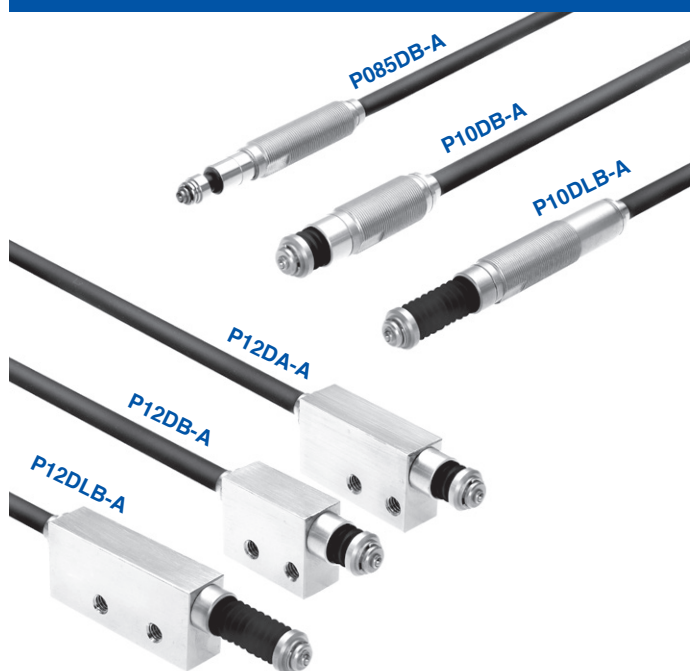

### Features

- **Small signal point adjustment variance**  
Repetitive accuracy of 0.5 μm (range)  
Wrong decision and short time breakdowns due to wrong signals can be reduced.
- **Can be used in harsh environment**  
Tightly sealed waterproof structure switch corresponding to IP67.
- **No movement differential**  
Minute displacement can be continuously detected.
- **No temperature drift**  
No signal point drift due to the voltage of the power supply or self-generation.
- **Low current, low voltage switch that has a long life (3 million cycles) when used within the rated range.**

### Standard specification

unit:mm

Shape	Product name	Output mode	Pretravel	Stroke	Size	with LED
Cylinder type (Threaded / Non-threaded)	P085DB-A	B : Normally close	0 (*1)	3	M8×0.5	P085DB-A-L
	P08SB-A				φ8	P08SB-A-L
	P10DA-A	A : Normally open	0.2		M10×0.5	P10DA-A-L
	P10DB-A	B : Normally close	0 (*1)			P10DB-A-L
	P10SA-A	A : Normally open	0.2		φ10	P10SA-A-L
	P10SB-A	B : Normally close	0 (*1)			P10SB-A-L
	P10DLB-A					P10DLB-A-L
Square type	P12DA-A	A : Normally open	0.2	3	10×18×31	P12DA-A-L
	P12DB-A	B : Normally close	0 (*1)		10×18×23	P12DB-A-L
	P12DLB-A				10×18×39	P12DLB-A-L

-A: Contacting part Sφ2 ball carbide

-L: LED indicator (120mm from the switch)

\*1 Adjust the installed location of the switch by the signal switching point.

### Common specification

unit:mm

Switch structure	Dry contact
Output mode	A : Normally open / B : Normally close
Repeatability	Both On→Off, Off→On/ 0.0005 (range) (At operating speed 50-200mm/min) *2
Movement differential	0
Contact life time	3 million (If no specified bungle caused by vibration and used under voltage and current rating)
Protective structure	IP67
Contact force	1N
Case material	SUS303 *BsBM+Ni Plating for P12D series
Standard accessory	Two fixing nuts for threaded type

\*2 Operating speed slower than 10mm/min is not recommended.

Cable (Refer to P7-5)	Standard length 3 m Oil resistant φ5 / 2 cores, φ4 / 2 cores for P085DB, P08SB, Tensile strength 30N, minimum bending R7
Operating temperature range	0°C-80°C (Ice-free)
Temperature drift	0 (because of no amplifier)
Oscillation	10-55Hz total amplitude 1.5 for X,Y,Z each direction
Impact	300m/s <sup>2</sup> for X,Y,Z each direction
Contact rating (Refer to P14-3)	DC5V-DC24V Steady current: 10 mA or less (rush current: 20 mA or less) <b>When using the switch with LED, limit the current below 10mA.</b>

◎The following options are available.

- Transistor output (Refer to P7-3)
- Reverse connect protection.
- Level conversion.
- Output current is increased to 100mA.
- Shape of contacting part
- Protective cover
- LED indicator
- Contact force
- Cable direction
- Cable



Outer dimension

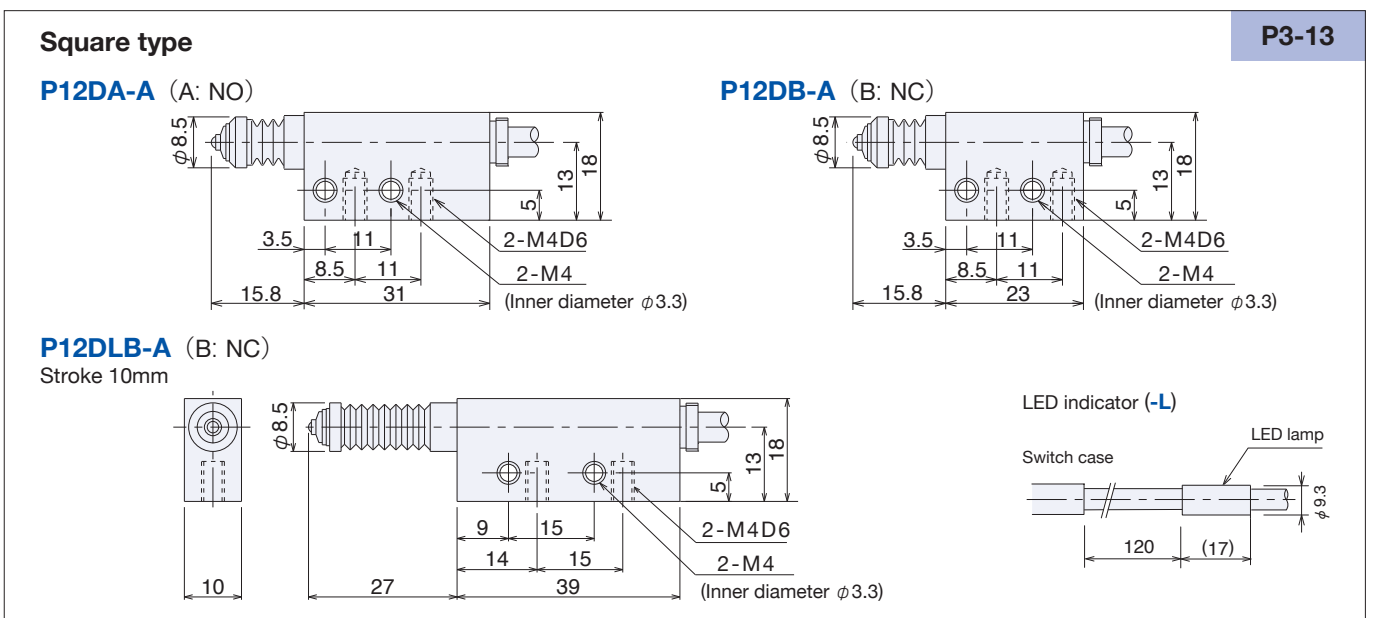
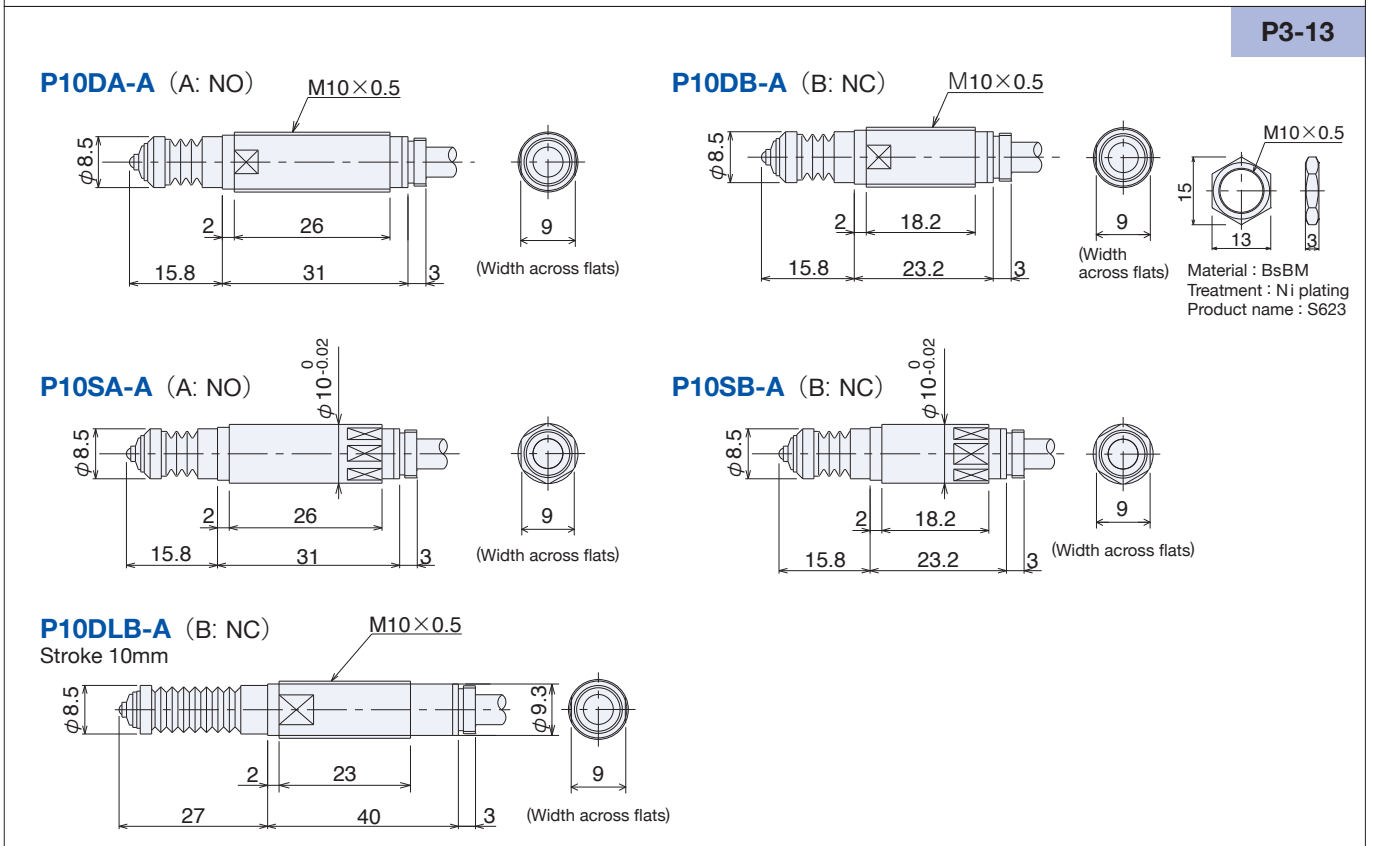
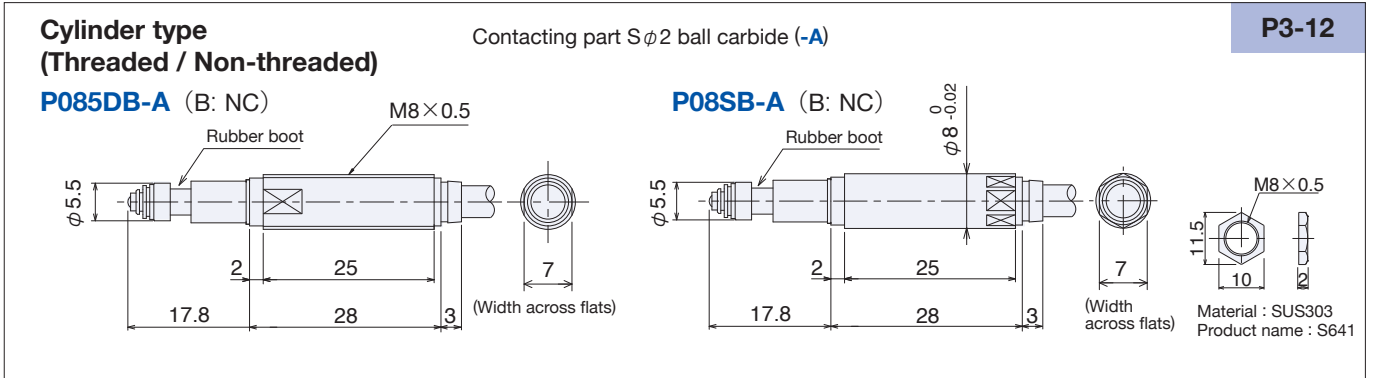

Options

Product name	Shape of contacting part	Protective cover	LED indicator	Contact force	Cable
<b>Cylinder type</b> <b>P085DB</b> <b>P08SB</b>	<b>A (Standard):</b> S $\phi$ 2 ball carbide  <b>B:</b> $\phi$ 3 flat carbide	<b>Blank:</b> Not required  <b>U:</b> Upward (Not available for "S" contact force option)	<b>Blank:</b> No LED  <b>L:</b> 120mm from the switch	<b>Blank:</b> 1N  <b>S:</b> 0.3N (No rubber boot is provided.IP40)  <b>G:</b> 0.5N  <b>H:</b> 1.5N	<b>Blank:</b> Standard (3m)  <b>5:</b> 5m
<b>Transistor                      output</b>  <b>TNA</b> Added to standard product name <b>TNB</b> <b>TPA</b> <b>TPB</b>  (Refer to P7-3)					

- ▶ e.g.) P085DB-AL-5
- ▶ Transistor output  
e.g.) P085DBTNA-AL-5

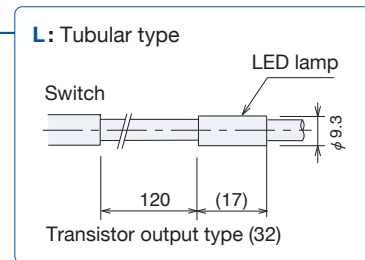
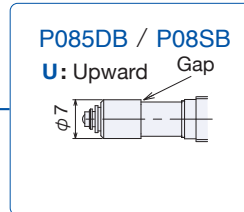
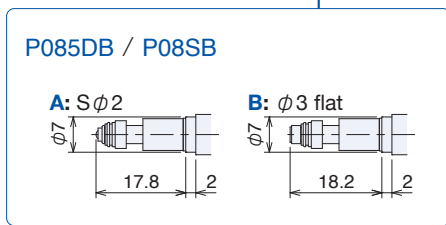

Shape of contacting part

Mark: Shape	Shape of detected objects
A: S $\phi$ 2 ball carbide	Flat
B: $\phi$ 3 flat	Convex, ball (Cutters, drills)

Contact force

Mark: Shape	Operating condition
S: 0.3N	No chattering caused by vibration or impact
G: 0.5N	(No rubber boot is provided for "S", IP40)
H: 1.5N	Intense vibration or impact

Refer to P6-2 for low contact force type (0.1N)

#### Options

Product name	Shape of contacting part	Protective cover	LED indicator	Contact force	Cable direction	Cable	Cable protection (Refer to P3-15)
<b>Cylinder type</b> <b>P10DA</b> <b>P10DB</b> <b>P10SA</b> <b>P10SB</b> <b>P10DLB</b> <b>Square type</b> <b>P12DA</b> <b>P12DB</b> <b>P12DLB</b>	<b>A (Standard):</b> S $\phi$ 2 ball carbide  <b>B:</b> $\phi$ 3 flat carbide  <b>T:</b> Replaceable (Threaded M2.5) No contacting part  * Contacting parts are sold separately (Refer to the next page)	<b>Blank:</b> Not required  <b>U:</b> Upward (Not available for non threaded type) (Not available for "S" contact force option)	<b>Blank:</b> No LED  <b>L:</b> 120mm from the switch	<b>Blank:</b> 1N  <b>S:</b> 0.3N (No rubber boot is provided.IP40)  <b>G:</b> 0.5N  <b>H:</b> 1.5N	<b>Blank:</b> Straight  <b>R:</b> 90° (Only P12 series can be applied)	<b>Blank:</b> Standard (3m)	<b>Blank:</b> Not required <3m cable> <b>W2:</b> 2m wire braid <b>P2:</b> 2m protective tube

Transistor output	
<b>TNA</b>	Added to standard product name
<b>TNB</b>	
<b>TPA</b>	
<b>TPB</b>	
(Refer to P7-3)	

- ▶ e.g.) P10DB-AL-5W4
- ▶ Transistor output e.g.) P10DBTNA-AL-5W4

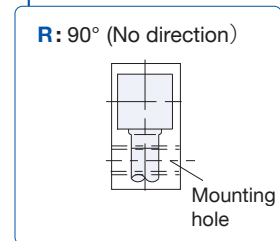
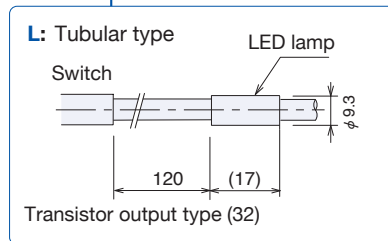

#### P10DA / P10DB / P10SA / P10SB

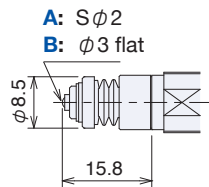

**T:** Replaceable (Threaded M2.5)  
No contacting part

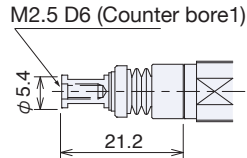

#### P12DA / P12DB

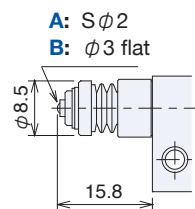

**T:** Replaceable (Threaded M2.5)  
No contacting part

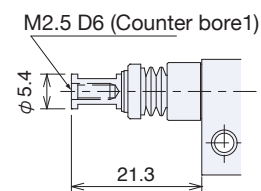

#### P10DLB

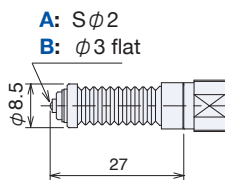

**T:** Replaceable (Threaded M2.5)  
No contacting part

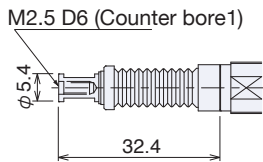

Compatible with contacting parts of commercially produced dial gauges

#### P12DLB

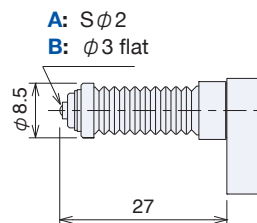

**T:** Replaceable (Threaded M2.5)  
No contacting part

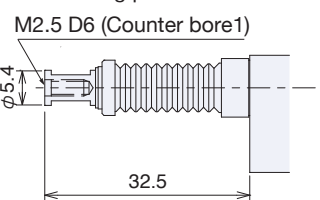

Compatible with contacting parts of commercially produced dial gauges

#### P10DA / P10DB

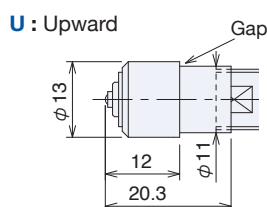

#### P10DLB

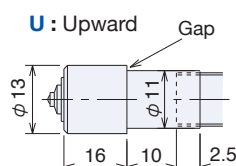

#### P12DA / P12DB

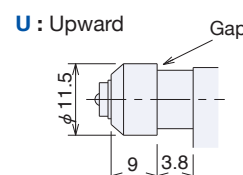

#### P12DLB

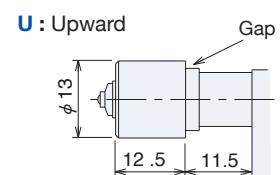

#### ■ Specification of option

#### Shape of contacting part

Mark: Shape	Shape of detected objects
A: S $\phi$ 2 ball carbide	Flat
B: $\phi$ 3 flat	Convex, ball (Cutters, drills)
T: Replaceable (Threaded M2.5)	Specify mounting direction when using special shape or heavy contacting parts

#### Contact force

Mark: Shape	Operating condition
S: 0.3N	No chattering caused by vibration or impact (No rubber boot is provided for "S", IP40)
G: 0.5N	
H: 1.5N	Intense vibration or impact

Refer to P6-2 for low contact force type (0.1N)

#### ■ Detachable contacting parts (sold separately)

#### Fixed contacting parts

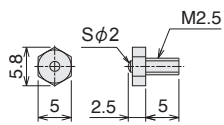
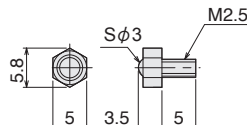
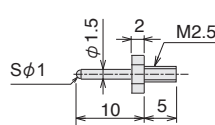
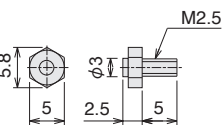
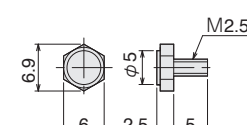
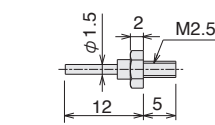
Outer dimension	Product name	Outer dimension	Product name	Outer dimension	Product name
<p>S<math>\phi</math>2 ball</p> 	<p><b>F4130W</b> Tungsten carbide</p>	<p>S<math>\phi</math>3 ball</p> 	<p><b>F4150W</b> Tungsten carbide</p>	<p>Needle</p> 	<p><b>F4129W</b> Tungsten carbide</p>
<p><math>\phi</math>3 flat</p> 	<p><b>F4131W</b> Tungsten carbide</p>	<p><math>\phi</math>5 flat</p> 	<p><b>F4132W</b> Tungsten carbide</p>	<p>Flat needle</p> 	<p><b>F4161W</b> Tungsten carbide</p>

This can make installation process easier and eliminate the risk of twisting the cable when adjusting the signal point of the switch.

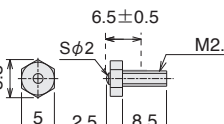
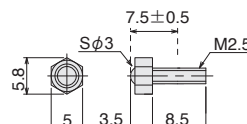
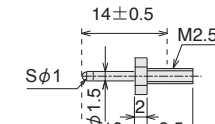
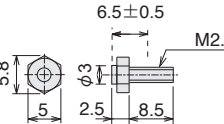
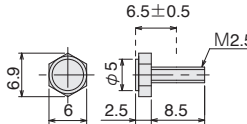
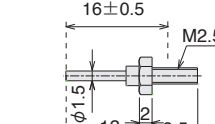
Outer dimension	Product name	Outer dimension	Product name	Outer dimension	Product name
<p>S<math>\phi</math>2 ball</p> 	<p><b>F4130AW</b> Tungsten carbide</p>	<p>S<math>\phi</math>3 ball</p> 	<p><b>F4150AW</b> Tungsten carbide</p>	<p>Needle</p> 	<p><b>F4129AW</b> Tungsten carbide</p>
<p><math>\phi</math>3 flat</p> 	<p><b>F4131AW</b> Tungsten carbide</p>	<p><math>\phi</math>5 flat</p> 	<p><b>F4132AW</b> Tungsten carbide</p>	<p>Flat needle</p> 	<p><b>F4161AW</b> Tungsten carbide</p>

Accessory for the adjustable contacting parts : Locknut for adjustment

#### Protective covers

U: Mostly for upward installation

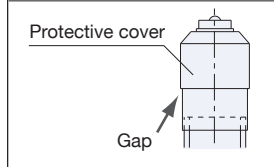

#### Precaution for attaching to brackets

When using protective covers or special contacting parts, insert cable side in the mounting hole. (In the case of using connector, undo it before insertion)

#### Precautions for installation of nuts :

When any of the following options is selected, the cover must be removed before installing the nut. (These options come with instructions for installing nuts.)

#### For metal cuttings and coolant

- Protective cover is strongly recommended to avoid damage from cuttings and coolant when the switch is used in machining environment. In addition, an extra cover is recommended to avoid direct hit by high-pressure coolant or heavy cuttings.
- For horizontal mounting, an extra cover prevents coolant or cuttings from entering inside and getting piled up on the body.
- Fabricate and place an extra cover to avoid metal chips adhering to the rubber boots during the grinding operation.

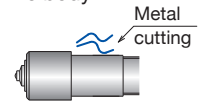

**Cable protection** (Protective structure, Refer to P14-5)

**Wire braid for protection**

Material : Steel wire, Clockwise tight winding  
Minimum bending radius : 7mm  
Mark : **W**

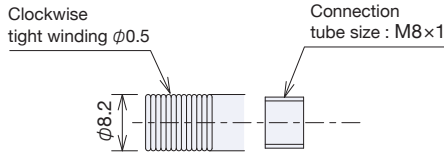

**Precautions**

- 1) Switch side is fastened with screws and machine side is simply cut. When extension is needed, use threaded connection tube.
- 2) Since gaps are formed at bend section (especially at the attachment end) of the wire braid, make sure the instruction of cuttings does not damage the cable.
- 3) Be careful not to damage the cable sheath as a result of crushing it during clamping.
- 4) When binding it up and clamp with other cables, make sure not to apply excessive force to the attachment end.
- 5) Wire braids extend by their own weight. Fabricate wire braids slightly shorter than the cable length.

**How to use**

Make contact with the object at right angle.  
Do not press the plunger to the stroke end. It may cause malfunction due to the impact.

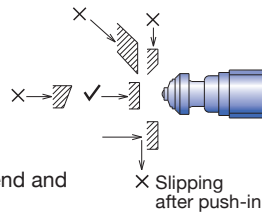

Action is limited between the tip end and the edge of the internal bearing.  
The end face may deform when the detector is hit, causing the failure in the return.

If there is a possibility to press the plunger to the stroke end, install a stopper separately to prevent the malfunction.

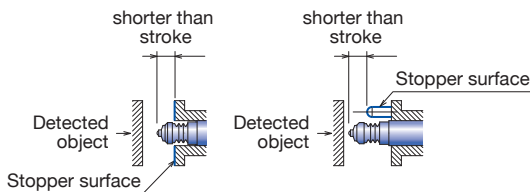

**How to set the signal point with adjustable contacts**

Fine adjustment by the contact screw. (About ±0.5)  
The switch is locked in position with the nut.

- 1) This also serves to prevent loosening.
- 2) Particularly convenient for making internal adjustment in machines.

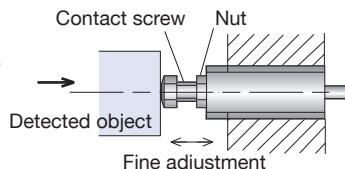

Extracted from Technical Guide P14-6

**Protective tube**

Used mainly in machining environment (Protection for cuttings).  
(Not applicable to the cable having diameter smaller than φ5)

Dimension : outer diameter φ9  
Minimum bending radius : 25mm  
Mark : **P**

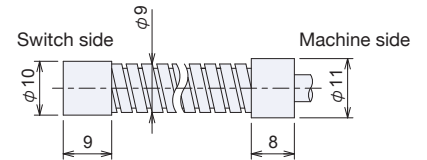

**Precautions**

- 1) Switch side is screwed in and metal ring is attached to machine side.
- 2) Because protective tube is not flexible, clamp it to fix so as not to apply excessive force to the switch.
- 3) When binding it up and clamping with other cables, make sure not to apply excessive force to the attachment end.
- 4) Cables are not waterproof.

**Tightening torque for case screws and nuts**

High-precision MT-Touch Switch	Screw / Nut	Tightening torque	Applicable models
	M8×0.5	4N·m	<b>P085DB</b>
	M10×0.5	8N·m	<b>P10</b>

**Circuit diagram**

without LED	with LED
<p>Normally open (NO)</p> <p>Brown + Blue -</p>	<p>Normally open (NO)</p> <p>Brown + Blue - LED Normally Off</p>
<p>Normally close (NC)</p> <p>Brown + Blue -</p>	<p>Normally close (NC)</p> <p>Brown + Blue - LED Normally On</p>

Electrical specification / circuit diagram. (Refer to P7-2)

When using the switches with LED option, limit the current below 10mA. (Refer to P14-3 "Confirmation of switch operation")

## P10DH

1-signal plunger type (Ball bearing)

### Sliding and angled touch type

#### Features

- A linear movement ball bearing makes it optimum for slide and deflection angle contacts.



#### 《Application》

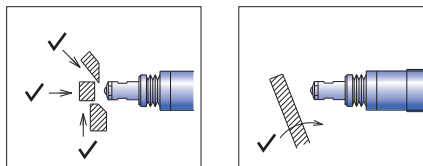

\* Photo shows the contacting part ( F4130W ) attached.

#### Standard specification

unit:mm

Product name	Output mode	Pretravel	Stroke	Size	with LED
P10DHA-T	A : Normally open	0.2	3	M14×0.5	P10DHA-T L
P10DHB-T	B : Normally close	0 (*1)			P10DHB-T L
P10SHA-T	A : Normally open	0.2		φ14	P10SHA-T L
P10SHB-T	B : Normally close	0 (*1)	10	M14×0.5	P10SHB-T L
P10DHLTB-T					P10DHLTB-T L

\*1 Adjust the installed location of the switch by the signal switching point.

-L: LED indicator (120mm from the switch)

#### Common specification

unit:mm

Switch structure	Dry contact	Cable	Standard length 3 m Oil resistant φ5 / 2 cores, Tensile strength 30N, minimum bending R7
Output mode	A : Normally open / B : Normally close	(Refer to P7-5)	
Repeatability	Both On→Off, Off→On/ 0.0005 (axial direction) (At operating speed 50-200mm/min) <sup>*2</sup>	Operating temperature range	0°C-80°C (Ice-free)
Movement differential	0	Temperature drift	0 (because of no amplifier)
Contact life time	3 million (If no specified bungle caused by vibration and used under voltage and current rating)	Oscillation	10-55Hz total amplitude 1.5 for X,Y,Z each direction
Protective structure	IP67	Impact	300m/s <sup>2</sup> for X,Y,Z each direction
Contact force	1N (axial direction)	Contact rating (Refer to P14-3)	DC5V-DC24V Steady current: 10 mA or less (rush current: 20 mA or less) <b>When using the switch with LED, limit the current below 10mA.</b>
Plunger shaft	Anti-rotating lock	Standard accessory	Two fixing nuts for threaded type

\*2 Operating speed slower than 10mm/min is not recommended.

#### ◎The following options are available.

- Transistor output (Refer to P7-3)
  - Reverse connect protection.
  - Level conversion.
  - Output current is increased to 100mA.
- Shape of contacting part
- Protective cover
- LED indicator
- Contact force
- Cable direction
- Cable

Outer dimension

**P10DHA-T (A: NO)**

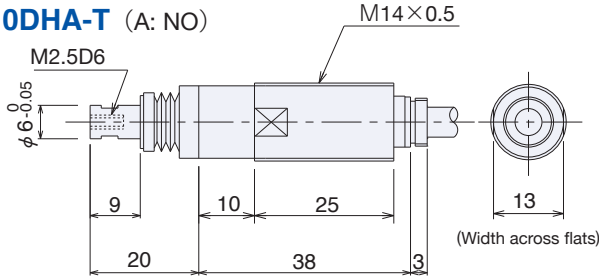

**P10DHB-T (B: NC)**

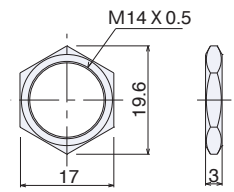
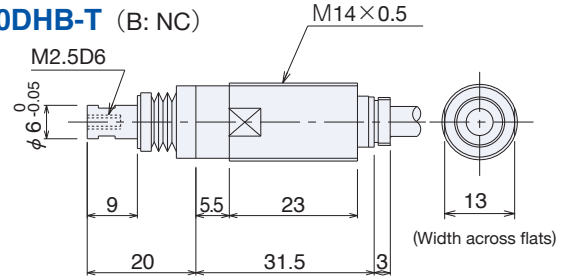

Material : BsBM  
Treatment : Ni plating  
Product name : S621

**P10SHA-T (A: NO)**

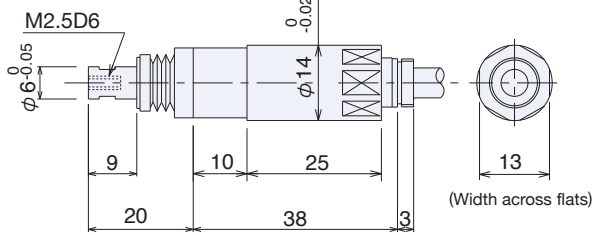

**P10SHB-T (B: NC)**

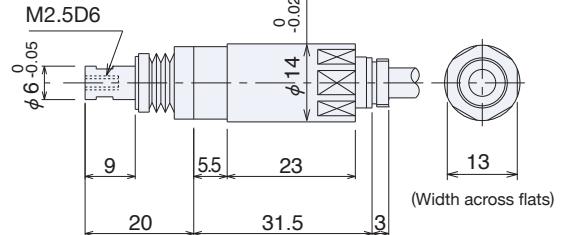

(-L: LED indicator)

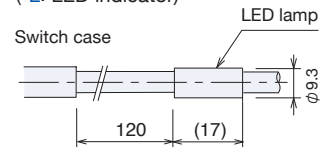

Long stroke type

**P10DHLTB-T (B: NC) \*3**

Stroke 10mm

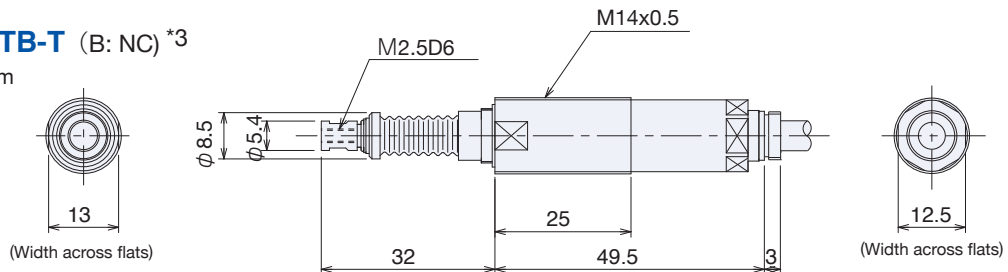

\*3 Conventional contact integrated one-piece type has been changed to removable type.



## Options

Product name	Shape of contacting part	Protective cover	LED indicator	Contact force	Cable direction	Cable	Cable protection (Refer to P3-15)
P10DHA P10DHB P10SHA P10SHB P10DHLTB	<b>T:</b> Replaceable (Threaded M2.5) No contacting part  * Contacting parts are sold separately (Refer to the next page)	<b>Blank:</b> Not required  <b>D:</b> Downward (Not available for "S" contact force option)  <b>U:</b> Upward (Not available for "S" contact force option)	<b>Blank:</b> No LED  <b>L:</b> 120mm from the switch	<b>Blank:</b> 1N  <b>S:</b> 0.3N (No rubber boot is provided. IP40.)  <b>G:</b> 0.5N <b>H:</b> 1.5N	<b>Blank:</b> Straight  <b>R:</b> 90° (unavailable when boot protection shape <b>U</b> is selected, except for P10DHLTB)	<b>Blank:</b> Standard (3m)  <b>5:</b> 5m	<b>Blank:</b> Not required <3m cable> <b>W2:</b> 2m wire braid <b>P2:</b> 2m protective tube  ----- <5m cable> <b>W4:</b> 4m wire braid <b>P4:</b> 4m protective tube

Transistor output
Added to standard product name  <b>TNA</b> <b>TNB</b> <b>TPA</b> <b>TPB</b> (Refer to P7-3)

- ▶ e.g.) P10DHA-TDL-5
- ▶ Transistor output
- e.g.) P10DHATNA-T

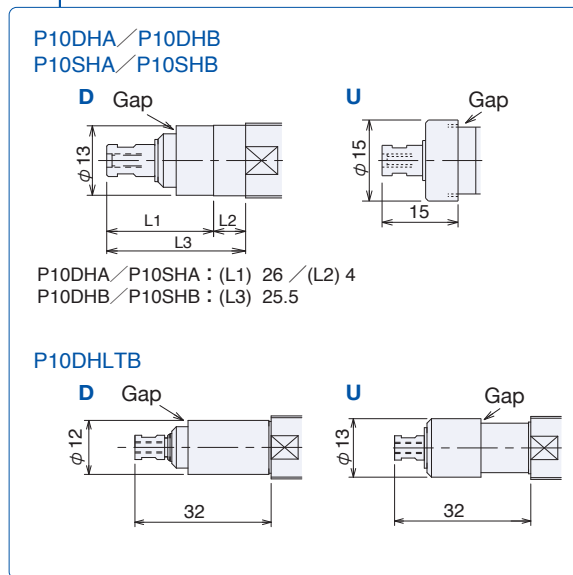
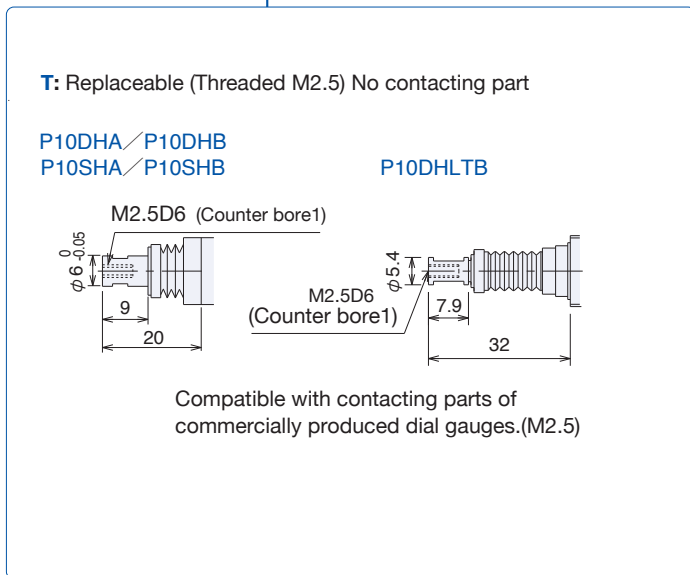
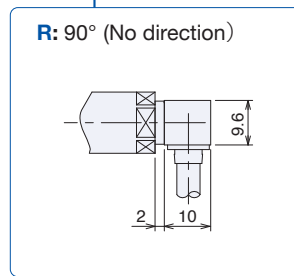
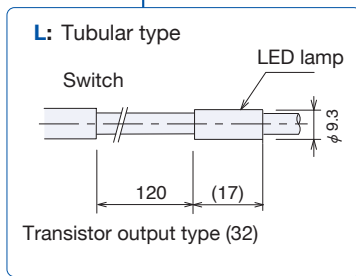

**Options**

**Shape of contacting part**

<b>Mark:</b> Shape	Operating condition
<b>T:</b> Replaceable (Threaded M2.5)	Specify mounting direction when using special shape or heavy contacting part

**Protective covers**

Choose the suitable cover according to switch mounting direction so that the metal cuttings and coolant can't enter from the gaps. (Refer to P14-5)

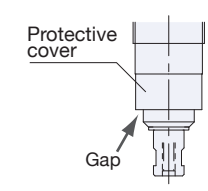
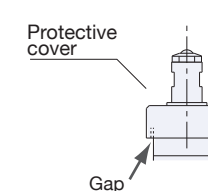
<b>D:</b> Mostly for downward installation	<b>U:</b> Mostly for upward installation
	

**Precaution for attaching to brackets**

When using U type protective covers or special contacting parts, insert cable side in the mouting hole.

**Contact force**

<b>Mark:</b> Shape	Operating condition
<b>S:</b> 0.3N	No chatting caused by vibration or impact (No rubber boot is provided for "S", IP40)
<b>G:</b> 0.5N	
<b>H:</b> 1.5N	Intense vibration or impact

**For metal cuttings and coolant**

- Protective cover is strongly recommended to avoid damage from cuttings and coolant when the switch is used in machining environment.
- In addition, an extra cover is recommended to avoid direct hit by high-pressure coolant or heavy cuttings.
- For horizontal mounting, an extra cover prevents coolant or cuttings from entering inside and getting piled up on the body.
- Fabricate and place an extra cover to avoid metal chips adhering to the rubber boots during the grinding operation.

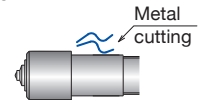

**Detachable contacting parts (sold separately)**

**Fixed contacting parts**

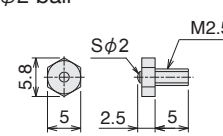
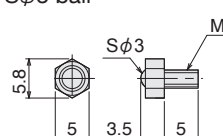
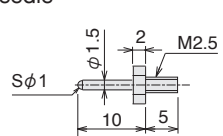
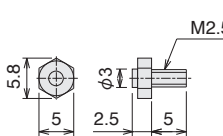
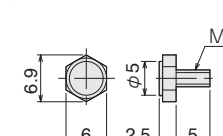
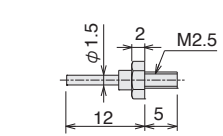
Outer dimension	Product name	Outer dimension	Product name	Outer dimension	Product name
Sφ2 ball 	<b>F4130W</b> Tungsten carbide	Sφ3 ball 	<b>F4150W</b> Tungsten carbide	Needle 	<b>F4129W</b> Tungsten carbide
φ3 flat 	<b>F4131W</b> Tungsten carbide	φ5 flat 	<b>F4132W</b> Tungsten carbide	Flat needle 	<b>F4161W</b> Tungsten carbide

**This can make installation process easier and eliminate the risk of twisting the cable when adjusting the signal point of the switch.**

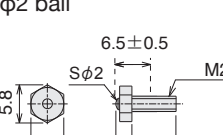
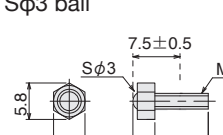
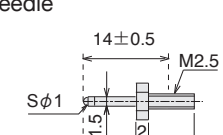
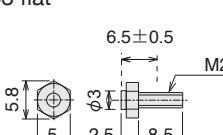
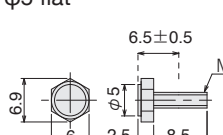
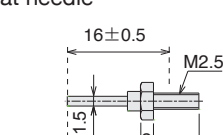
Outer dimension	Product name	Outer dimension	Product name	Outer dimension	Product name
Sφ2 ball 	<b>F4130AW</b> Tungsten carbide	Sφ3 ball 	<b>F4150AW</b> Tungsten carbide	Needle 	<b>F4129AW</b> Tungsten carbide
φ3 flat 	<b>F4131AW</b> Tungsten carbide	φ5 flat 	<b>F4132AW</b> Tungsten carbide	Flat needle 	<b>F4161AW</b> Tungsten carbide

Accessory for the adjustable contacting parts : Locknut for adjustment

**Cable protection** (Protective structure, Refer to P14-5)

**Wire braid for protection**

Material : Steel wire, Clockwise tight winding  
Minimum bending radius : 7mm  
Mark : **W**

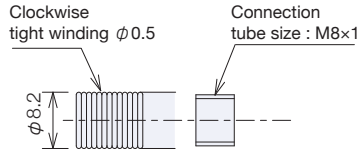

**Precautions**

- 1) Switch side is fastened with screws and machine side is simply cut. When extension is needed, use threaded connection tube.
- 2) Since gaps are formed at bend section (especially at the attachment end) of the wire braid, make sure the instruction of cuttings does not damage the cable.
- 3) Be careful not to damage the cable sheath as a result of crushing it during clamping.
- 4) When binding it up and clamp with other cables, make sure not to apply excessive force to the attachment end.
- 5) Wire braids extend by their own weight. Fabricate wire braids slightly shorter than the cable length.

**How to set the signal point with adjustable contacts**

Fine adjustment by the contact screw. (About ±0.5)  
The switch is locked in position with the nut.

- 1) This also serves to prevent loosening.
- 2) Particularly convenient for making internal corrections.

Extracted from  
Technical Guide P14-6

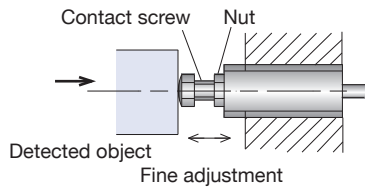

**Circuit diagram**

without LED	with LED
<p>Normally open (NO)</p> <p>Brown + Blue -</p>	<p>Normally open (NO)</p> <p>Brown + Blue -</p> <p>LED Normally Off</p>
<p>Normally close (NC)</p> <p>Brown + Blue -</p>	<p>Normally close (NC)</p> <p>Brown + Blue -</p> <p>LED Normally On</p>

Electrical specification / circuit diagram. (Refer to P7-2)

**When using the switches with LED option, limit the current below 10mA.** (Refer to P14-3 "Confirmation of switch operation")

**Protective tube**

Used mainly in machining environment (Protection for cuttings).  
(Not applicable to the cable having diameter smaller than φ5)

Dimension: outer diameter φ9  
Minimum bending radius : 25mm  
Mark : **P**

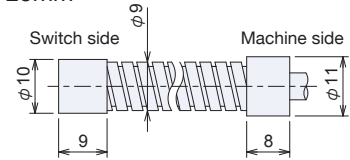

**Precautions**

- 1) Switch side is screwed in and metal ring is attached to machine side.
- 2) Because protective tube is not flexible, clamp it to fix so as not apply excessive force to the switch.
- 3) When binding it up and clamping with other cables, make sure not to apply excessive force to the attachment end.
- 4) Cables are not waterproof.

**How to use**

Suitable for sliding and angled objects.

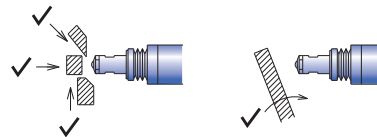

Action is limited between the tip end and the edge of the internal bearing.

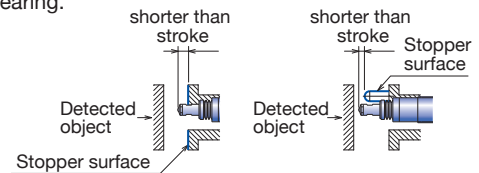

If there is a possibility to press the plunger to the stroke end, install a stopper separately to prevent the malfunction.

**Tightening torque for case screws and nuts**

	Screw / Nut	Tightening torque	Applicable models
High-precision MT-Touch Switch	M14x0.5	10N · m	<b>P10DH</b>



## P11

1 signal flat type

### Straight touch type (Metal bearing)

PAT.PEND.

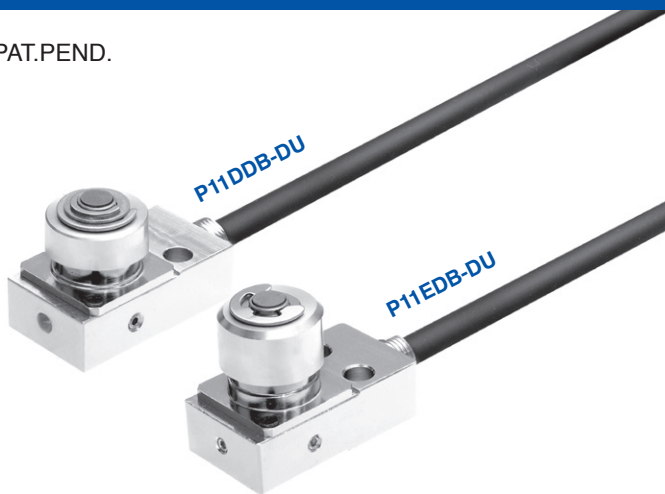

#### Features

■ **Installation** : Due to there is no fine tuning mechanism for signal setting, use as follows.

- The origin for the object which is moving or displacing
- Ideal for tool setter of the NC machine (Usable for the thermal displacement correction of machine)
- Providing the adjustment section to the moving object (Refer to P14-6 Technical guide - Setting methods)

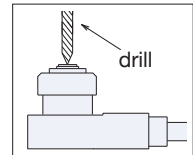

■ Since this will be used at the circumstances which the coolant and cutting chips spatter, the typical specification will be gap-less, boot protection.

■ Parallelism : 0.01mm

■ Contact diameter : Up to  $\phi 10$

#### Standard specifications

unit mm

Product name	Stroke	Mounting hole	With LED
P11DDB-DU	3	2- $\phi 4.6$	P11DDB-DU LD
P11DMB-DU		2-M4	P11DMB-DU LD
P11EDB-DU	5	2- $\phi 4.6$	P11EDB-DU LD
P11EMB-DU		2-M4	P11EMB-DU LD

-DU :  $\phi 5$  Flat carbide,  
Protective cover for upward installation

LD : LED indicator (attached to the sensor)

#### Common specifications

unit mm

Contact structure	Dry contact
Output mode	B : Normally close
Pretravel	0*1
Repeatability	Both ON→OFF OFF→ON 0.0005 (range) (At operating speed 50-200mm/min)*2
Movement differential	0
Contact life time	3 million ( If no specified bungle caused by vibration and ) ( used under voltage and current rating )
Protective structure	IP67
Contact force	1.5N

Cable (Refer to P7-5)	Standard length 3m Oil resistant $\phi 5 / 2$ cores Tensile strength 30N, Minimum bending R7
Operating temperature range	0°C-80°C (Ice-free)
Temperature drift	0 (because of no amplifier)
Oscillation	10-55Hz total amplitude 1.5 for X,Y,Z each direction
Impact	300m/s <sup>2</sup> for X,Y,Z each direction
Contact rating (Refer to P14-3)	DC5V - DC24V Steady current : 10mA or less Rush current : 20mA or less When using the switches with LED option, limit the current below 10mA.

\*1 Adjust the installed location of the sensor by the signal switching point.

\*2 Operating speed slower than 10mm/min is not recommended.

◎ The following options are available.

- Transistor output (Refer to P7-3)
- Air pipe
- Contact force
- Reverse connect protection.
- Shape of contacting part
- Cable direction
- Level conversion.
- Protective covers
- Cable
- Output current is increased to 100mA.
- LED indicator

Outer dimension

φ5 Flat carbide (-D)  
Protective cover for upward installation (U)

**P11DDB-DU** (B : NC)

**P11DMB-DU** (B : NC)

Stroke 3mm

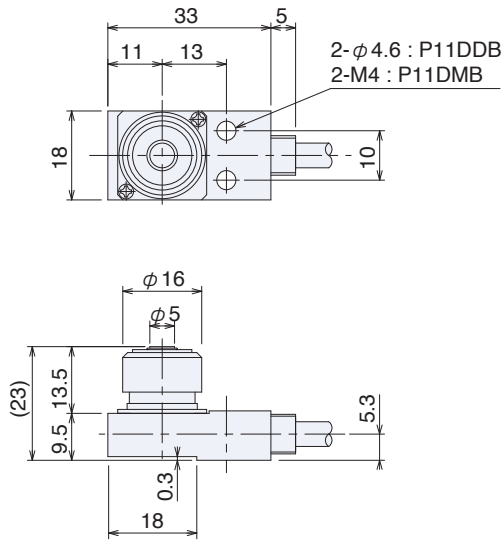

**P11EDB-DU** (B : NC)

**P11EMB-DU** (B : NC)

Stroke 5mm

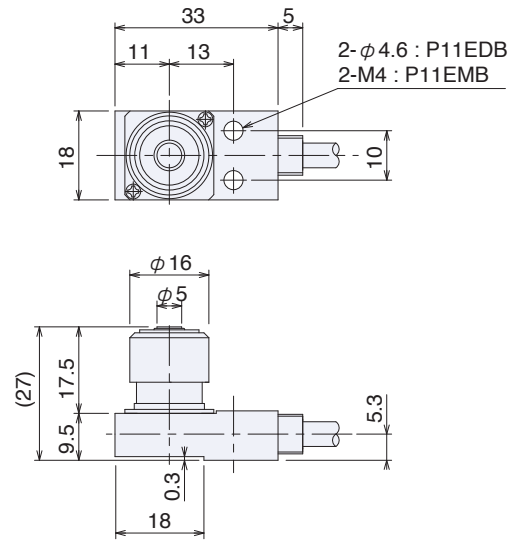

Circuit diagram

Without LED	With LED
<p>Nomally Closed (NC)</p>	<p>Nomally Closed (NC)</p>

Electrical specification / circuit diagram. (Refer to P7-2)

**When using the sensors with LED option, limit the current below 10mA**  
(refer to P14-3 "Confirmation of Sensor Operation" ).

How to use

Make contact with detected objects at right angle.

Action is limited between the tip end and the edge of the bearing. The end face of the bearing may deform when the detector is hit, causing the failure in the return.

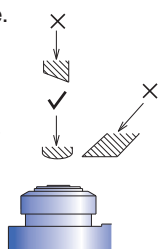

#### Options

Product name	Shape of contacting part	Protective cover	LED indicator	Contact force	Cable direction	Cable	Cableprotection (Refer to P3-25)
<b>P11DDB</b> <b>P11DMB</b> <b>P11EDB</b> <b>P11EMB</b>	<b>Standard D :</b> $\phi 5$ flat carbide  <b>A :</b> $\phi 2$ ball carbide  <hr/> <b>F :</b> $\phi 10$ flat carbide (Only applicable for P11DDB/P11DMB)	<b>Standard U :</b> For upward installation  <b>D :</b> For downward installation (Not available for "F" contacting part)  <b>Blank :</b> Not required (Not available for "F" contacting part)	<b>Blank :</b> Not required  <b>LD :</b> attached to the sensor	<b>Blank :</b> 1.5N  <b>K :</b> 1N (Not available for "F" contacting part)	<b>Blank :</b> Straight  <b>R3 :</b> 90°	<b>Blank:</b> Standard (3m)  <hr/> <b>5 :</b> 5m	<b>Blank:</b> Not required <3m cable> <b>W2 :</b> 2m wire braid <b>P2 :</b> 2m protective tube  <hr/> <5m cable> <b>W4 :</b> 4m wire braid <b>P4 :</b> 4m protective tube

Transistor output	Air pipe
Added to standard product name  <b>TNA</b> <b>TNB</b> <b>TPA</b> <b>TPB</b>  (refer to P7-3)	<b>Blank :</b> Not required  <b>P/PR :</b> Added to standard product name or after transistor output (refer to P3-25)

- ▶ e.g.) P11DDB-DULDR3-5
- ▶ Transistor output e.g.) P11DDBTNA-DU
- ▶ Air pipe e.g.) P11DDBP-DU

**LD:** attached to the sensor

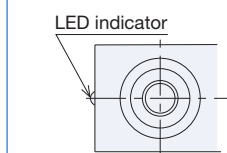

**R3**

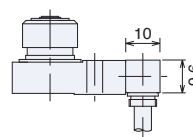

**A :** S  $\phi 2$

P11DDB/P11DMB : (L) 13.9  
P11EDB/P11EMB : (L) 17.9

**D :**  $\phi 5$  flat

P11DDB/P11DMB : (L) 13.5  
P11EDB/P11EMB : (L) 17.5

**F :**  $\phi 10$  flat Only applicable for P11DDB / P11DMB

▶ e.g.) P11DDB-FU

**D**

P11DDB/P11DMB : (L) 13.5  
P11EDB/P11EMB : (L) 17.5

**U**

P11DDB/P11DMB : (L) 13.5  
P11EDB/P11EMB : (L) 17.5



**Cable protection** (Protective structure, Refer to P14-5)

**Wire braid for protection**

Material : Steel wire, Clockwise tight winding  
Minimum bending radius : 7mm  
Mark : **W**

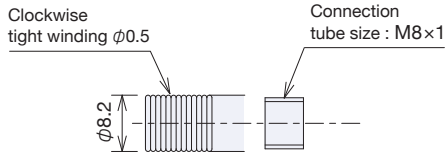

**Precautions**

- 1) Switch side is fastened with screws and machine side is simply cut. When extension is needed, use threaded connection tube.
- 2) Since gaps are formed at bend section (especially at the attachment end) of the wire braid, make sure the instruction of cuttings does not damage the cable.
- 3) Be careful not to damage the cable sheath as a result of crushing it during clamping.
- 4) When binding it up and clamp with other cables, make sure not to apply excessive force to the attachment end.
- 5) Wire braids extend by their own weight. Fabricate wire braids slightly shorter than the cable length.

**Options**

**Shape of contacting part**

Mark : Shape	Shape of detected objects
<b>D</b> : $\phi 5$ flat, carbide	Convex, ball (cutters, drills)
<b>A</b> : $\phi 2$ ball, carbide	Flat
<b>F</b> : $\phi 10$ flat, carbide	Convex, ball (cutters, drills)

**Contact force**

Mark : Contact force	Operating condition
<b>K</b> : 1N	Drills of $\phi 5$ or smaller

Refer to P6-2 for low contact force type (0.1N)

**Protective covers**

Choose a suitable cover such that metal cuttings and coolant do not enter from the gaps (horizontal types prevent coolant from penetrating and building up inside). (Refer to P14-5)

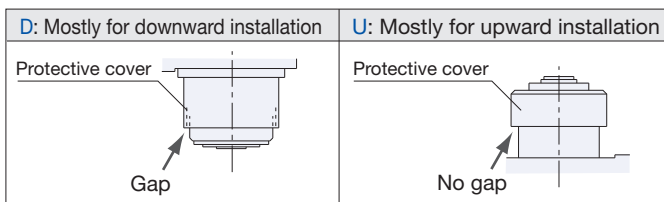

**Coolant and cutting chips**

As the rubber boots may be torn in an environment where chips can scatter and adhere or coolant can splash on the boots, be sure to select the boot protection.

In addition, please provide a separate cover if the high pressure coolant or water jet violently hit the contact or boots protection.

When using the protective cover in a horizontal position, be sure to provide a cover or the like so that the chips do not accumulate on the switch body.

When using a grinding machine, if polishing or grinding chips are deposited on the rubber surface, please provide a cover separately.

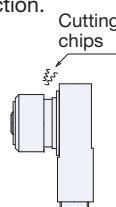

**Protective tube**

Used mainly in machining environment (Protection for cuttings). (Not applicable to the cable having diameter smaller than  $\phi 5$ )

Dimension : outer diameter  $\phi 9$   
Minimum bending radius : 25mm  
Mark : **P**

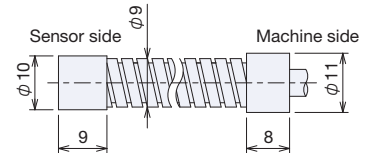

**Precautions**

- 1) Switch side is screwed in and metal ring is attached to machine side.
- 2) Because protective tube is not flexible, clamp it to fix so as not to apply excessive force to the switch.
- 3) When binding it up and clamping with other cables, make sure not to apply excessive force to the attachment end.
- 4) Cables are not waterproof.

**Air pipe**

Air pipes are used to blow off cuttings or coolant that have adhered to the contact surface or tool.

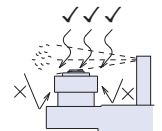

Product name
Standard product name + <b>P</b>
Standard product name + <b>PR</b>

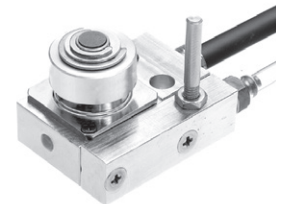

**Example**

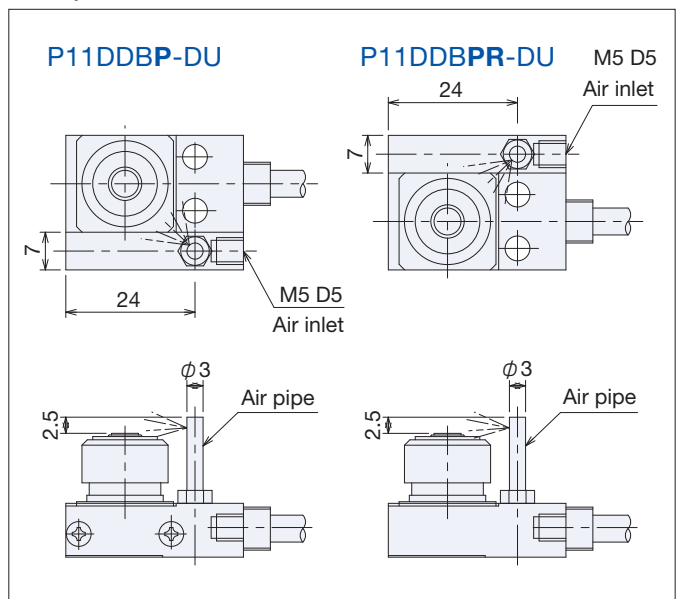

# CS-TOUCH SWITCH

Selection by how to touch the objects

**Straight touch**

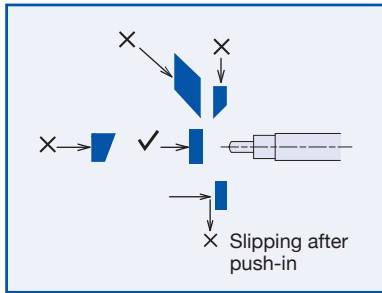

- Size: M5 / M6 / M8
- It is easy to adjust the set position thanks to fine thread.



- Size:  $\phi 5$  /  $\phi 6$  /  $\phi 8$
- With split clamp, position adjustment can be accurately done.



- Mini switch (M10×15)

**Sliding and angled touch**

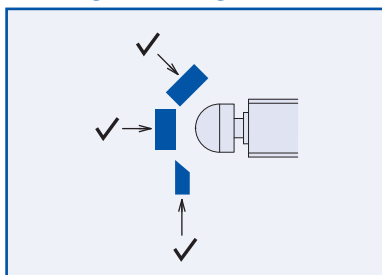

- Size : M8
- Ball bearing type
- IP67 Waterproof



- Size : M12
- Ball bearing type
- IP65 Waterproof

## Merits of CS-Touch Switch

### ■ Slim design allows side by side installation, wide range of variations.

From M5 size

### ■ High performance at reasonable price

Repetitive accuracy of 5 μm

### ■ No movement differential

Minute displacement can be continuously detected.



### ■ No temperature drift

No signal point drift due to the voltage of the power supply or self-generation.

### ■ Low current, low voltage switch that has a long life (10 million) when used within the rated range.

## ■ Product list

unit:mm

	Standard product name	Output mode	Protective structure	Size	Page
<b>Metal bearing</b> Threaded type/ Non-threaded type 	CSJ055A	A : Normally open	IP65	M5×0.5	P4-3
	CSJS50A			φ5	
	CS065A			M6×0.5	
	CSS60A / CSS60B	A : Normally open B : Normally close		φ6	
	CS067A / CS067B	A : Normally open		M6×0.75	
	CSS80A			φ8	
	CS087A	A : Normally open B : Normally close		M8×0.75	
	CSK087A / CSK087B		M8×0.75		
<b>Ball bearing type</b> Threaded type 	CSP087A / CSP087B	A : Normally open B : Normally close	IP67	M8×0.75	P4-9
	CSHP085A / CSHP085B		IP65	M12×1	P4-11
	CSH121A / CSH121B				

## Mini type

<b>Metal bearing</b> 	CSM105WA	A : Normally open	IP65	M10×0.5	P4-13
	CSM105CA		IP65		
	CSMP105CA		IP67		

# CS-Touch Switch

High-precision positioning switch series  
www.metrol.co.jp/en

## CS / CSJ / CSS / CSK / CSP

1-signal plunger type  
**Straight touch type (Metal bearing)**



### Features

■ **Slim design allows side by side installation, wide range of variations.**

From M5 / Long stroke / Water-resistant

■ **High performance at reasonable price**

5 micron in repetitive accuracy

### 《Application》

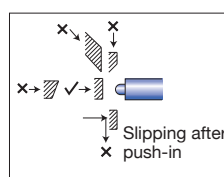

### Standard specification

unit:mm

	Product name	Output mode	Stroke	Size	Contacting part	Protective structure	with LED
Cylinder type (Threaded / Non-threaded)	CSJ055A	A : NO	2.8	M5×0.5	φ2 plunger, SR1.5 SUS, Hardened HRC50	IP65	CSJ055A-L
	CSJS50A			φ5			CSJS50A-L
	CS065A	A : NO		M6×0.5			CS065A-L
	CSS60 A / B	A : NO		φ6			CSS60A / B -L
	CS067 A / B	B : NC		M6×0.75			CS067A / B -L
	CSS80A	A : NO		φ8			CSS80A-L
CS087A	M8×0.75		CS087A-L				
Long stroke	CSK087 A / B	A : NO	5	M8×0.75	φ3.5 plunger, SR3 SUS, Hardened HRC50	IP67	CSK087A / B -L
Waterproof	CSP087 A / B-A	B : NC	2.8				Sφ2 SUS, Hardened HRC50

-A : Contacting part φ2 ball, SUS, Hardened HRC50

-L : LED indicator (120mm from the switch)

### Common specification

unit:mm

Switch structure	Dry contact	Cable (Refer to P7-5)	Standard length 3m Oil resistant φ2.8 / 2 cores, Tensile strength 30N, minimum bending R7
Output mode	A : Normally open / B : Normally close	Operating temperature range	0°C-80°C (Ice-free)
Pretravel	0.3	Temperature drift	0 (because of no amplifier)
Repeatability	Both On→Off, Off→On/ 0.005 (range) (At operating speed 50-200mm/min) *	Oscillation	10-55Hz total amplitude 1.5 for X,Y,Z each direction
Movement differential	0	Impact	300m/s <sup>2</sup> for X,Y,Z each direction
Contact life time	10million (If no specified bungle caused by vibration and used under voltage and current rating)	Contact rating (Refer to P14-3)	DC5V-DC24V Steady current: 10 mA or less (rush current: 20 mA or less)  When using the switch with LED, limit the current below 10mA.
Contact force	1N		
Case material	SUS HRC50		
Standard accessory	Two fixing nuts for threaded type		

\* Operating speed slower than 10mm/min is not recommended.

#### ◎The following options are available.

- Transistor output (Refer to P7-3)
  - Reverse connect protection.
  - Level conversion.
  - Output current is increased to 100mA.
- Shape of contacting part
- Protective cover
- LED indicator
- Contact force
- Cable direction
- Heat-resistance (P6-4)

Outer dimension

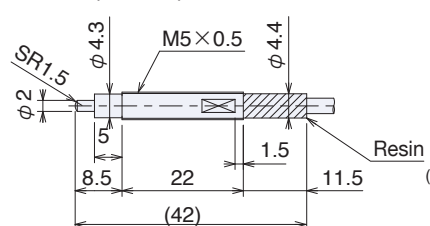
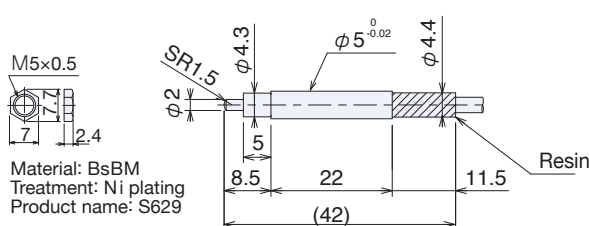
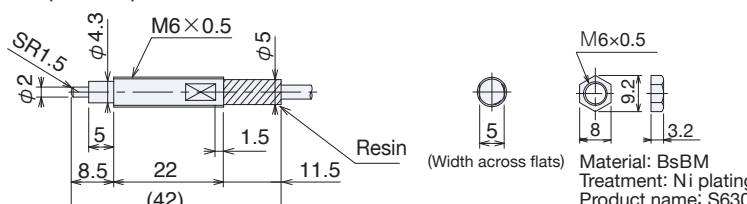
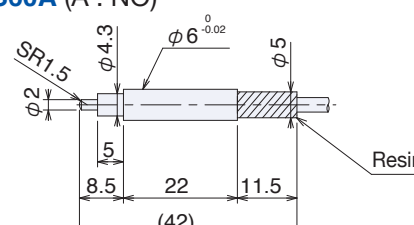
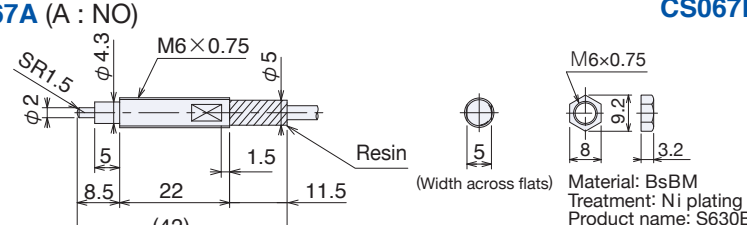
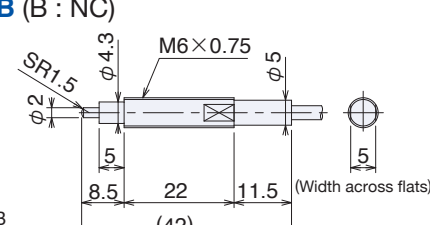
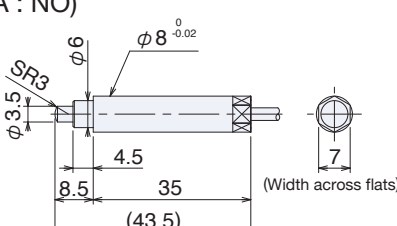
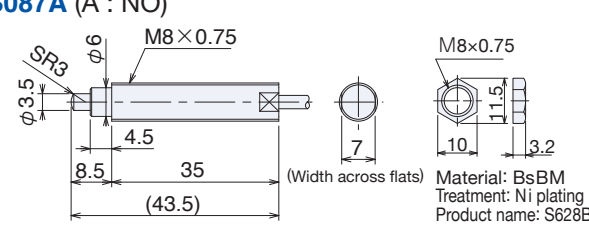
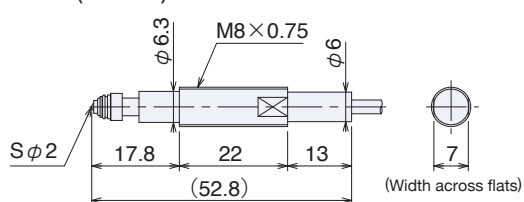
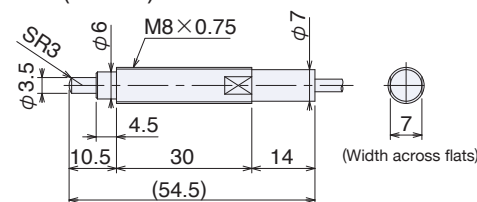
M5 / $\phi 5$	<p><b>CSJ055A (A : NO)</b></p> 	<p><b>CSJS50A (A : NO)</b></p> 
	<p><b>CS065A (A : NO)</b></p> 	<p><b>CSS60A (A : NO)</b></p> 
M6 / $\phi 6$	<p><b>CS067A (A : NO)</b></p> 	<p><b>CS067B (B : NC)</b></p> 
	<p><b>CSS80A (A : NO)</b></p> 	<p><b>CS087A (A : NO)</b></p> 
M8 / $\phi 8$	<p><b>Waterproof type (IP67)</b></p> <p><b>CSP087A-A (A : NO)</b> <b>CSP087B-A (B : NC)</b></p> 	<p><b>Long stroke type (Stroke 5mm)</b></p> <p><b>CSK087A (A : NO)</b> <b>CSK087B (B : NC)</b></p> 

## Cable direction 90°(Option)

### Features

- **Slim design allows side by side installation, wide range of variations.**

From M5 / long stroke / water-resistant

- **High performance at reasonable price**

5 micron in repetitive accuracy without an amplifier



### Representative specification (Cable direction 90°)

unit:mm

	Product name	Output mode	Stroke	Size	Contacting part	Protective structure	with LED
Cylinder type (Threaded/ Non-threaded)	CSJ055A-R	A : NO	2.8	M5×0.5	φ2 plunger, SR1.5 SUS, Hardened HRC50	IP65	CSJ055A-LR
	CSJS50A-R			φ5			CSJS50A-LR
	CS065A-R	A : NO	2.8	M6×0.5	φ2 plunger, SR1.5 SUS, Hardened HRC50	IP65	CS065A-LR
	CSS60A-R			φ6			CSS60A-LR
	CS067A-R			M6×0.75			CS067A-LR
		CSS80A-R	A : NO	2.8	φ8	φ3.5 plunger, SR3 SUS, Hardened HRC50	IP65
CS087A-R		M8×0.75			CS087A-LR		
Long stroke	CSK087 A / B -R	A : NO B : NC	5	M8×0.75			CSK087 A / B -LR

-R: Cable direction 90°

-L: LED indicator (120mm from the switch)

**Caution:** If the shape of contact is larger than the screw or case diameter,

it cannot be inserted through the installation hole. In such case, please use either a split bush or by a bracket U-cut, etc.

### Common specification

unit:mm

Switch structure	Dry contact
Output mode	A : Normally open / B : Normally close
Pretravel	0.3
Repeatability	Both On→Off, Off→On/ 0.005(range) (At operating speed 50~200mm/min)*
Movement differential	0
Contact life time	10million (If no specified bungle caused by vibration and used under voltage and current rating)
Contact force	1N
Case material	SUS HRC50
Standard accessory	Two fixing nuts for threaded type

Cable (Refer to P7-5)	Standard length 3m Oil resistant φ2.8 / 2 cores, Tensile strength 30N, minimum bending R7 Cable protector (Detachable)
Operating temperature range	0°C~80°C (Ice-free)
Temperature drift	0
Vibration	10-55Hz total amplitude 1.5 for X,Y,Z each direction
Shock	300m/s <sup>2</sup> for X,Y,Z each direction
Contact rating (Refer to P14-3)	DC5V-DC24V Steady current: 10 mA or less (rush current: 20 mA or less) <b>When using the switch with LED, limit the current below 10mA.</b>

#### ◎The following options are available.

• Transistor output (Refer to P7-3)

- Reverse connect protection.
- Level conversion.
- Output current is increased to 100mA.

- Shape of contacting part
- Protective cover
- LED indicator
- Contact force
- Cable direction
- Heat-resistance (P6-4)

\*Operating speed slower than 10mm/min is not recommended.

**Outer dimension**

**M5 / φ5 Threaded / Non-threaded Cable direction: -R (90°)**

**CSJ055A - R (A: NO)**

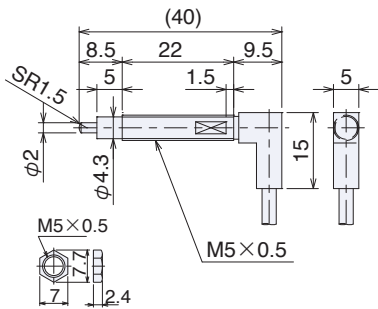

Material: BsBM  
Treatment: Ni plating  
Product name: S629

**CSJS50A - R (A: NO)**

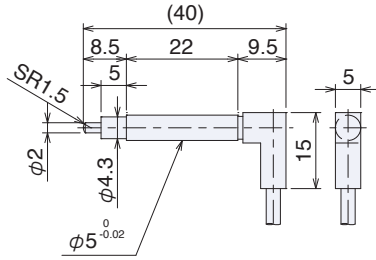

**CS065A - R (A: NO)**

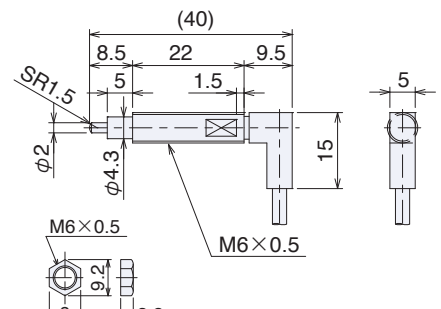

Material: BsBM  
Treatment: Ni plating  
Product name: S630

**M6 / φ6 Threaded / Non-threaded Cable direction: -R (90°)**

**CSS60A - R (A: NO)**

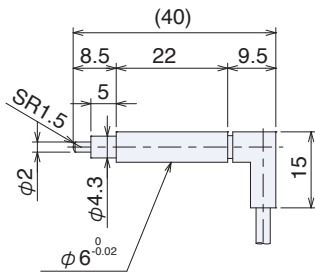

**CS067A - R (A: NO)**

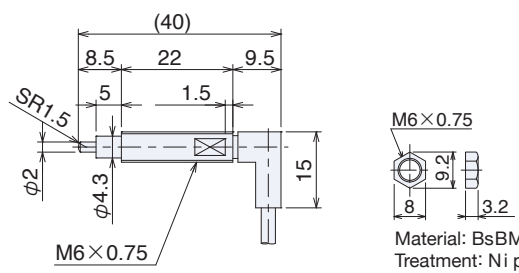

Material: BsBM  
Treatment: Ni plating  
Product name: S630B

**M8 / φ8 Threaded / Non-threaded Cable direction: -R (90°)**

**CSS80A - R (A: NO)**

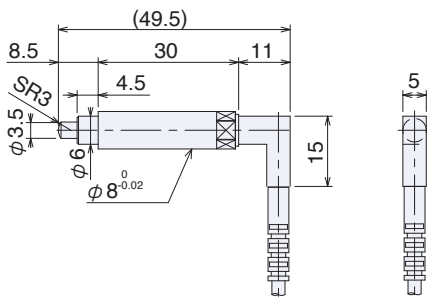

**CS087A - R (A: NO)**

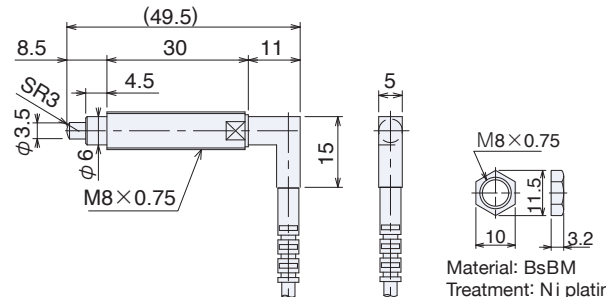

Material: BsBM  
Treatment: Ni plating  
Product name: S628B

**Long stroke type Cable direction: -R (90°)**

**CSK087A - R (A: NO)**

**CSK087B - R (B: NC)**

Stroke 5mm

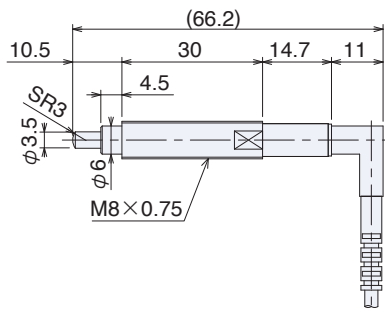

LED indicator

-L□R: Specify the position >120mm

LED indicator

-LD□R: Switch

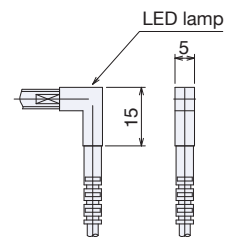
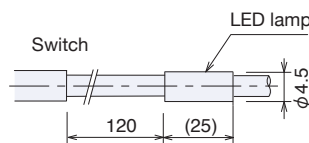



Options

Product name	Shape of contacting part	Protective cover	LED indicator	Contact force	Cable direction
φ2 plunger <b>CSJ055A</b> <b>CSJS50A</b> <b>CS065A</b> <b>CSS60 A / B</b> <b>CS067 A / B</b>	<b>Blank:</b> φ2 plunger SR1.5 <b>A:</b> φ2 flat <b>B:</b> φ4 flat <b>C:</b> Needle <b>DP:</b> Plastic	<b>Blank:</b> Not required	<b>Blank:</b> No LED <b>L:</b> 120mm from the switch <b>LD *:</b> Attached to the switch *Available only when perpendicular cable direction <b>R</b> is selected.	<b>Blank:</b> 1N <b>S:</b> 0.3N <b>G:</b> 0.5N <b>H:</b> 1.5N (The rubber scraper is not provided for "S". IP40) (Normally close type not acceptable for <b>S</b> and <b>G</b> )	<b>Blank:</b> Straight <b>R:</b> 90° (Normally close type not acceptable for <b>R</b> )
φ3.5 plunger <b>CSS80A</b> <b>CS087A</b> <b>CSK087 A / B</b>	<b>Blank:</b> φ3.5 plunger SR3 <b>B:</b> φ3.5 flat			<b>Blank:</b> 1N <b>S:</b> 0.3N <b>G:</b> 0.5N <b>H:</b> 1.5N (The rubber scraper is not provided for <b>S,G</b> . IP40) (Normally close type not acceptable for <b>S</b> and <b>G</b> )	<b>Blank:</b> Straight <b>R:</b> 90°
<b>Water resistant type</b> <b>CSP087 A / B</b>	<b>A(Standard):</b> Sφ2 ball SUS, Hardened steel <b>B:</b> φ3 flat	<b>Blank:</b> No protective <b>D:</b> Downward <b>U:</b> Upward	<b>Blank:</b> No LED <b>L:</b> 120mm from the switch	<b>Blank:</b> 1N	<b>Blank:</b> Straight

**Transistor output**

**TNA** Added to standard product name  
**TNB**  
**TPA**  
**TPB**

(Refer to P7-3)

- ▶ e.g.) CSJ055A-ALSR
- ▶ Transistor output e.g.) CSJ055ATNA

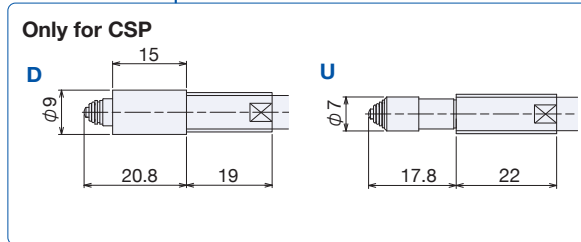

**R: 90° (Not available for CSP)**

CSJ055A / CSJS50A  
 CS065A / CSS60A / CS067A  
 φ2 plunger : (L) 9.5  
 CSS80A / CS087A / CSK087 A / B  
 φ3.5 plunger : (L) 11

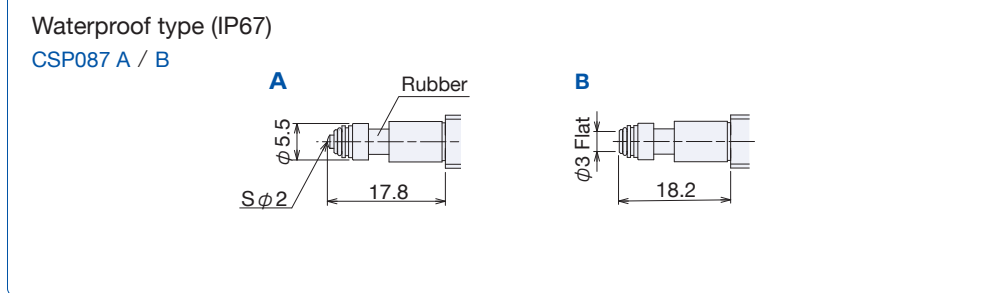
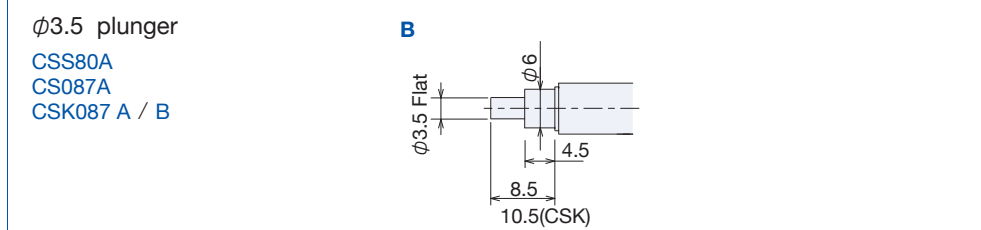
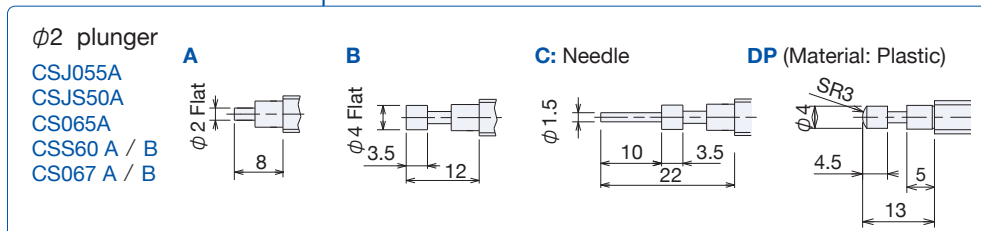

**L: Tubular type**

LED lamp

Switch

Transistor output type : φ9.3×(32)

**LD□R: Integrated with sensor \* (Not available for CSP)**

LED lamp

CSJ055A / CSJS50A  
 CS065A / CSS60A / CS067A  
 φ2 plunger : (L) 9.5  
 CSS80A / CS087A / CSK087 A / B  
 φ3.5 plunger : (L) 11

\*Available only when perpendicular cable direction **R** is selected.

Options

Shape of contacting part

Product name	Mark: Shape	Shape of detected objects
$\phi$ 2 plunger CSJ055A CSJS50A CS065A CSS60 A/B CS067 A/B	Blank: $\phi$ 2 plunger SR1.5 A: $\phi$ 2 flat B: $\phi$ 4 flat C: Needle DP: $\phi$ 3.5, SR3	Flat Convex, ball (Cutters, drills) The bottom of the deep hole, Small detected surface Flat
$\phi$ 3.5 plunger CSS80A CS087A CSK087 A/B	Blank: $\phi$ 3.5 plunger SR3 B: $\phi$ 3.5 flat	Flat Convex, ball (Cutters, drills)

Product name	Mark: Shape	Shape of detected objects
Waterproof (IP67) CSP087 A/B	A: S $\phi$ 2 ball carbide B: $\phi$ 3 flat	Flat Convex, ball (Cutters, drills)

Contact force (Not available for CSP)

Mark: Shape	Operating condition
S: 0.3N	No chattering caused by vibration or impact
G: 0.5N	(No rubber boot is provided for "S", IP40)
H: 1.5N	Intense vibration or impact

Refer to P6-2 for low contact force type (0.1N)

Protective covers (CSP only)

Choose the suitable cover according to switch mounting direction so that the metal cuttings and coolant can't enter from the gaps. (Refer to P14-5)

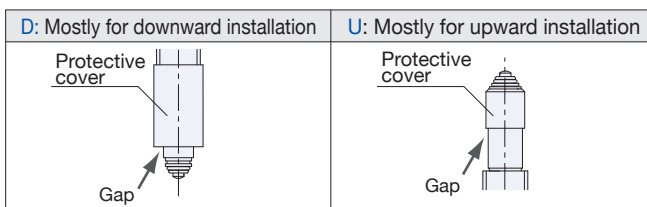

Note when installing on brackets, etc. :

When the diameter is large or a D shaped protection boot or special contact is used, pass the switch from the front side of the installation hole (remove the relay connector before installation).

Tightening torque for case screws and nuts

	Screw / Nut	Tightening torque	Applicable models
CS-Touch Switch	M5x0.5	2N · m	CSJ055
	M6x0.5	4N · m	CS065
	M6x0.75	4N · m	CS067
	M8x0.75	7N · m	CSP087

Circuit diagram

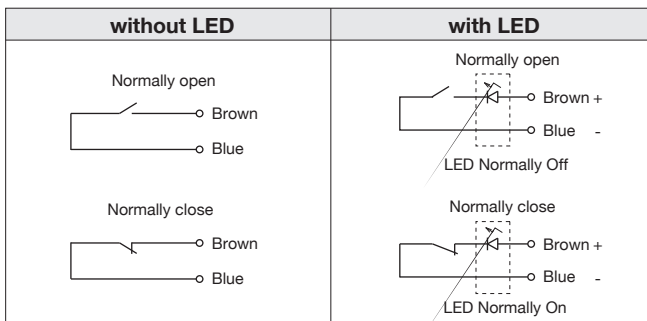

Electrical specification / circuit diagram. (Refer to P7-2)

When using the switches with LED option, limit the current below 10mA. (Refer to P14-3 "Confirmation of switch operation")

For metal cuttings and coolant (CSP only)

- Protective cover is strongly recommended to avoid damage from cuttings and coolant when the switch is used in machining environment. In addition, an extra cover is recommended to avoid direct hit by high-pressure coolant or heavy cuttings.
- For horizontal mounting, an extra cover prevents coolant or cuttings from entering inside and getting piled up on the body.
- Fabricate and place an extra cover to avoid metal chips adhering to the rubber boots during the grinding operation.

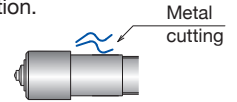

Protective structure

CSP type (IP67)

A rubber boot is applied to the plunger. As it has no rotation stopper, please do not twist the rubber boot by rotating the shaft.

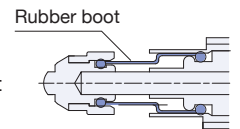

Product other than CSP (IP65)

Rubber scraper is applied to the plunger. When the lip of the scraper is damaged by cuttings, the water resistance becomes impaired.

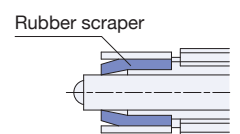

How to use

Make contact with detected objects at right angle (within deflection angle  $\pm 3^\circ$ )

If there is a possibility to press the plunger to the stroke end, install a stopper separately to prevent the malfunction.

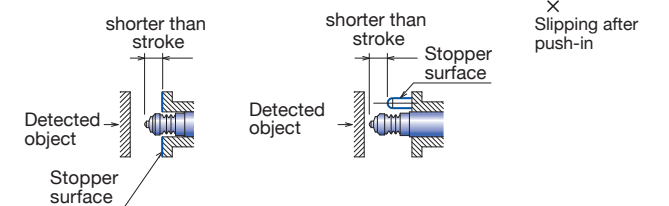

# CSHP

1 signal plunger type (Linear bushing bearing)  
**Sliding and angled touch, Waterproof type**



### Features

- A linear bushing bearing makes it optimum for slide and deflection angle contacts.
- IP67 protective structure, can be used in harsh environment.

### 《Application》

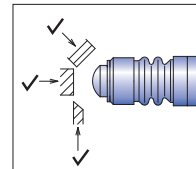

### Standard specification

unit: mm

Product name	Output mode	Contacting part	With LED
CSHP085A	A : NO	φ4.7 plunger SR3 SUS, Hardened HRC45-50	CSHP085A-L
CSHP085B	B : NC		CSHP085B-L

-L : LED indicator (120mm from the switch)

### Common specification

unit: mm

Switch structure	Dry contact
Output mode	A : Normally open / B : Normally close
Pretravel	0.3
Stroke	2.8 (axial direction)
Repeatability	Both On→Off, Off→On/ 0.005 (axial direction) (At operating speed 50-200mm/min)*
Movement differential	0
Contact life time	10 million (If no specified bungle caused by vibration and used under voltage and current rating)
Protective structure	IP67
Contact force	1N (axial direction)
Plunger shaft	No rotation stopper
Case material	SUS303

\* Operating speed slower than 10mm/min is not recommended

Cable (refer to P7-5)	Standard length 2m Oil resistant φ2.8/2 cores, Tensile strength 30N, Minimum bending R7
Operating temperature range	0°C-80°C (ice-free)
Temperature drift	0 (because of no amplifier)
Oscillation	10-55Hz total amplitude 1.5 for X,Y,Z each direction
Impact	300m/s <sup>2</sup> for X,Y,Z each direction
Contact rating (Refer to P14-3)	DC5V-DC24V Steady current: 10 mA or less (rush current: 20 mA or less) <b>When using the switches with LED option, limit the current below 10mA.</b>
Standard accessory	Two fixing nuts

### ◎The following options are available.

- Transistor output (Refer to P7-3)
  - Reverse connect protection
  - Level conversion
  - Output current is increased to 100mA.
- LED indicator

### ■Circuit diagram

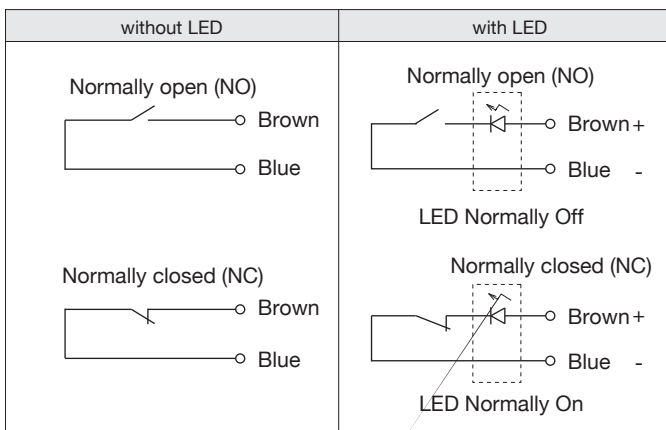

Electrical specification / circuit diagram. (Refer to P7-2)

**When using the switches with LED option, limit the current below 10mA.**  
 (Refer to P14-3 "Confirmation of switch operation")

### ■How to use

Suitable for sliding and angled objects.

Action is limited between the tip end and the edge of the internal bearing.

The end face may deform when the detector is hit, causing the failure in the return.

When sliding, be sure that rotational torque is not applied to the plunger shaft.

Do not press the contact to the stroke end.

If there is a possibility to press it to the stroke end, install a stopper separately to prevent malfunction.

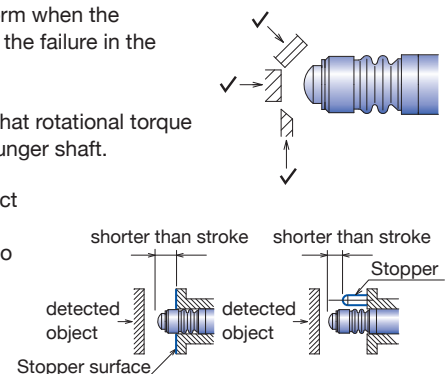

■ Outer dimension

**CSHP085A** (A : NO)  
**CSHP085B** (B : NC)

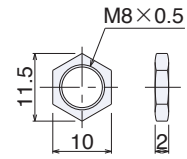
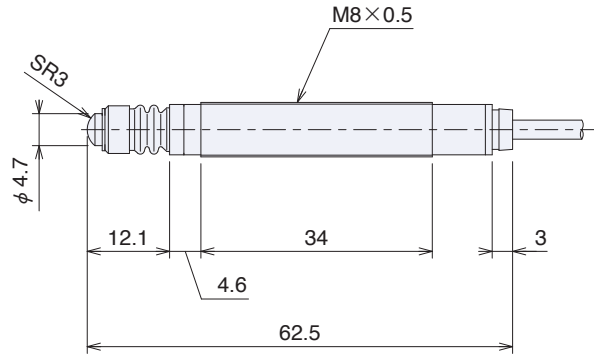

Material : SUS303  
 Product name : S641

■ Options

Product name	LED indicator
<b>CSHP085A</b> <b>CSHP085B</b>	<b>Blank</b> : No LED  <b>L</b> : 120mm from the switch

Transistor output	L : Tubular type
<b>TNA</b> Added to standard product name <b>TNB</b> <b>TPA</b> <b>TPB</b>  (Refer to P7-3)	<p>Transistor output type : <math>\phi 9.3 \times (32)</math></p>

▶ e.g.) **CSHP085A-L**

▶ Transistor output e.g.) **CSHP085ATNA**

■ Tightening torque for case screws and nuts

	Screw/Nut	Tightening torque	Applicable model
<b>CS-Touch Switch</b>	M8x0.5	4N·m	<b>CSHP</b>

■ Protective structure

Rubber boots are used.

As it has no rotation stopper, please do not twist the rubber boot by rotating the shaft.

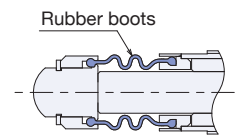



### Features

- A linear bushing bearing makes it optimum for slide and deflection angle contacts.

### 《Application》

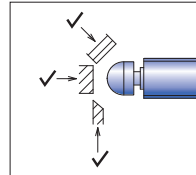

### Standard specification

Product name	Output mode	with LED
CSH121A-A	A : NO	CSH121A-AL
CSH121B-A	B : NC	CSH121B-AL

-A: S  $\phi$  10 hemisphere SUS, Hardened HRC 45-50

-L: LED indicator (120mm from the switch)

### Common specification

Switch structure	Dry contact
Output mode	A : Normally open / B : Normally close
Pretravel	0.3
Stroke	2.8 (axial direction)
Repeatability	Both On→Off, Off→On/ 0.005 (axial direction) (At operating speed 50-200mm/min)*1
Movement differential	0
Contact life time	10million (If no specified bungle caused by vibration and used under voltage and current rating)
Protective structure	IP65
Contact force	1.5N (axial direction)
Plunger shaft	No rotation stopper
Case material	SUS 303

\*1 Operating speed slower than 10mm/min is not recommended.

	unit:mm
Cable (Refer to P7-5)	Standard length 2m Oil resistant $\phi$ 4 / 2 cores, Tensile strength 30N, minimum bending R7
Operating temperature range	0°C-80°C (Ice-free)
Temperature drift	0 (because of no amplifier)
Oscillation	10-55Hz total amplitude 1.5 for X,Y,Z each direction
Impact	300m/s <sup>2</sup> for X,Y,Z each direction
Contact rating (Refer to P14-3)	DC5V-DC24V Steady current: 10 mA or less (rush current: 20 mA or less) <b>When using the switch with LED, limit the current below 10mA.</b>
Standard accessory	Two fixing nuts

### ◎The following options are available.

- Transistor output (Refer to P7-3)
- Shape of contacting part
- Reverse connect protection.
- LED indicator
- Level conversion.
- Contact force
- Output current is increased to 100mA.
- Cable

### ■Circuit diagram

without LED	with LED
<p>Normally open (NO)</p>	<p>Normally open (NO)</p>
<p>Normally close (NC)</p>	<p>Normally close (NC)</p>

Electrical specification / circuit diagram. (Refer to P7-2)

**When using the switches with LED option, limit the current below 10mA.** (Refer to P14-3 "Confirmation of switch operation")

## Outer dimension

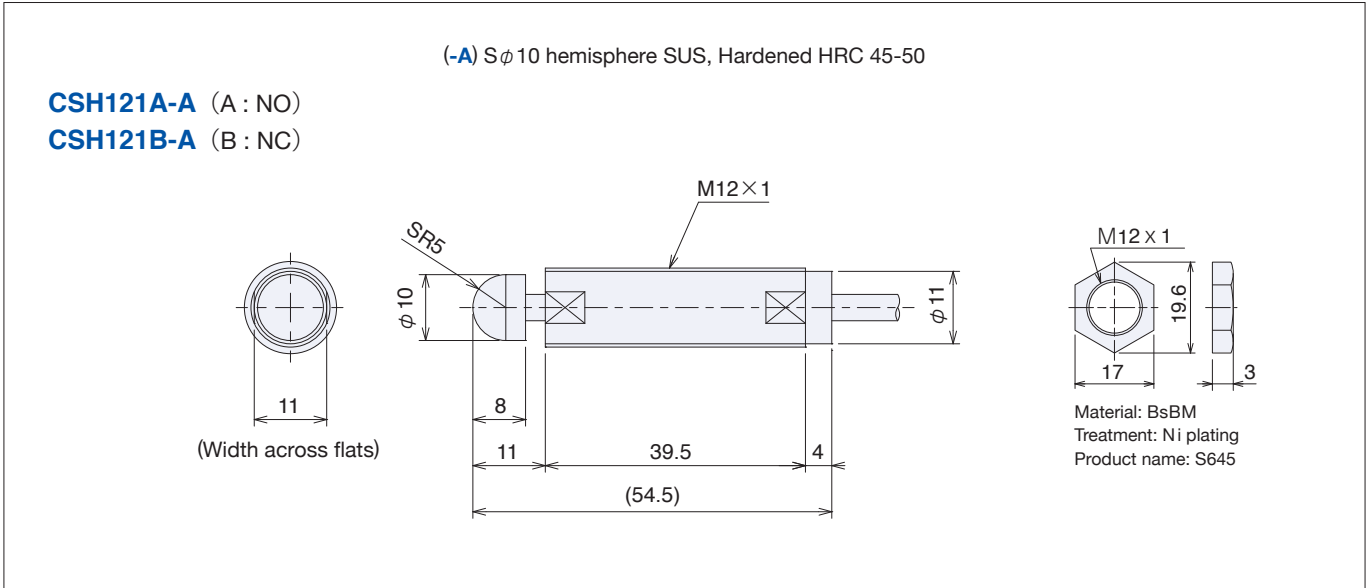

## Options

Product name	Shape of contacting part	LED indicator	Contact force
CSH121A CSH121B	<b>A(Standard):</b> Sφ10 hemisphere SUS, Hardened HRC45-50 <b>AP:</b> Sφ10 hemisphere plastic	<b>Blank:</b> No LED <b>L:</b> 120mm from the switch	<b>Blank:</b> 1.5N <b>J:</b> 0.8N (The rubber scraper is not provided for "J", IP40)

Transistor output
<b>TNA</b> Added to <b>TNB</b> standard <b>TPA</b> product <b>TPB</b> name  (Refet to P7-3)

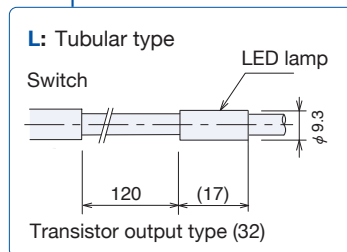
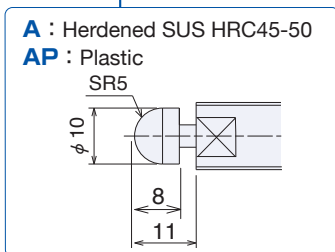

- ▶ e.g.) CSH121A-AL
- ▶ Transistor output  
e.g.) CSH121BTNA-A

## How to use

Suitable for sliding and angled objects.  
Action is limited between the tip end and the edge of the internal bearing.  
The end face may deform when the detector is hit, causing the failure in the return.

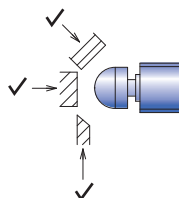

When sliding, be sure that rotational torque is not applied to the plunger shaft.

## Protective structure

Rubber scraper is applied to the plunger.  
When the lip of the scraper is damaged by cuttings, the water resistance becomes impaired.

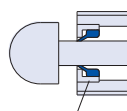

Rubber scraper

## Shape of contacting part

Mark: Shape	Operating condition
<b>A:</b> Sφ10 hemisphere	Flat (sliding, rotating objects)
<b>AP:</b> Sφ10 hemisphere plastic	

## Contact force

Mark: Shape	Operating condition
<b>J:</b> 0.8N	The rubber scraper is not provided for "J". (IP40)

## Tightening torque for case screws and nuts

	Screw / Nut	Tightening torque	Applicable model
CS-Touch Switch	M12x1	12N · m	CSH

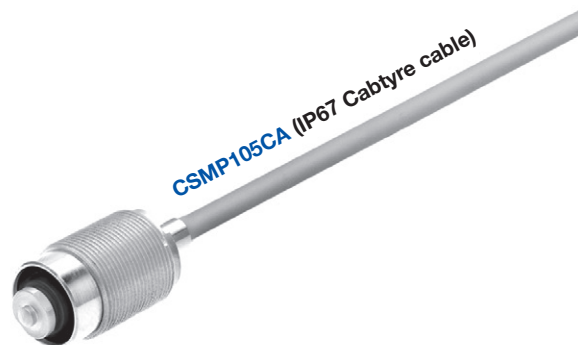

### Features

#### ■ Mini size

Suitable for machines required to be small and for narrow installation space.

### 《Application》

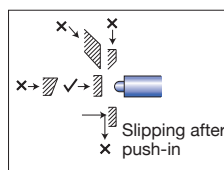

### ■ Standard specification

Output mode	Pretravel	Product name	Cable	Protective structure	Size	unit:mm with LED
A : Normally open	0.3	CSM105WA	Core-wire cable	IP65	M10×0.5	
		CSM105CA	Cabtyre cable			CSM105CA -L
		CSMP105CA		IP67		CSMP105CA -L

-L: LED indicator  
(120mm from the switch)

### ■ Common specification

Switch structure	Dry contact
Output mode	A : Normally open
Stroke	1.5
Repeatability	Both On→Off, Off→On/ 0.003 (range) (At operating speed 50-200mm/min)*1
Movement differential	0
Contact life time	10million (If no specified bungle caused by vibration and used under voltage and current rating)
Contact force	1N
Case material	SUS303
Contacting part material	SUS HRC50

\*1 Operating speed slower than 10mm/min is not recommended.

#### ◎ The following options are available.

- Transistor output (Refer to P7-3)
- LED indicator
- Reverse connect protection.
- Level conversion.
- Output current is increased to 100mA.

	unit:mm
Cable (Refer to P7-5)	Core-wire cable: 0.5m (×2) Oil-resistant $\phi$ 0.6 Tensile strength 15N Cabtyre cable: 2m Oil resistant $\phi$ 2.8 / 2 cores, Tensile strength 30N
Operating temperature range	0°C-80°C (Ice-free)*2
Temperature drift	0 (because of no amplifier)
Oscillation	10-55Hz total amplitude 1.5 for X,Y,Z each direction
Impact	300m/s <sup>2</sup> for X,Y,Z each direction
Contact rating (Refer to P14-3)	DC5V-DC24V Steady current : 10 mA or less (rush current: 20 mA or less) <b>When using the switch with LED, limit the current below 10mA.</b>
Standard accessory	One fixing nut and a spanner for threaded type

\*2 The sealed waterproof structure causes delay in return, when used under temperature (below 5°C) .

### ■ Protective structure

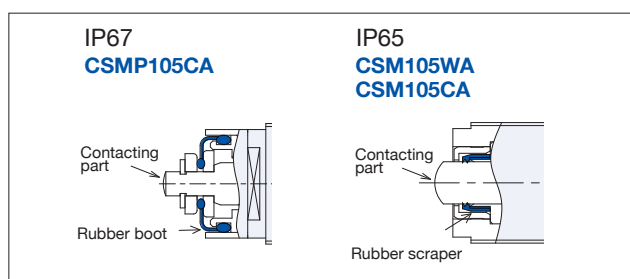

### ■ For metal cuttings and coolant

The products in this series are not suitable for operating in a harsh machining environment (even IP67 type) where coolant contains metal cuttings.

### ■ Tightening torque for case screws and nuts

	Screw / Nut	Tightening torque	Applicable model
CS-Touch Switch	M10x0.5	8N · m	CSM



**Outer dimension**

**Output mode A : NO**

**Core-wire cable (IP65)**

**CSM105WA** (A: NO)

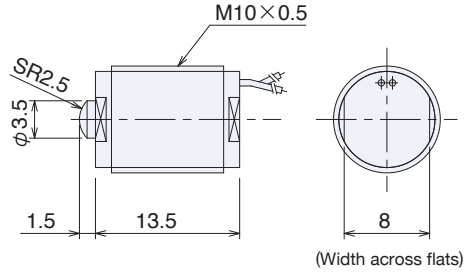

**Cabtyre cable (IP65)**

**CSM105CA** (A: NO)

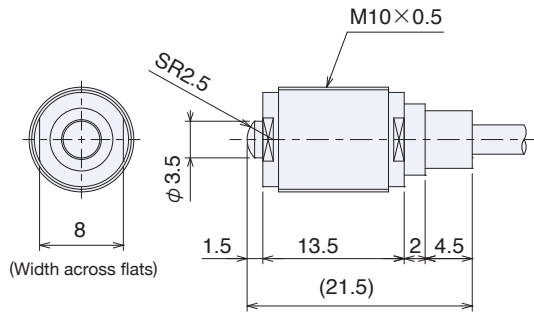

**Cabtyre cable Waterproof (IP67)**

**CSMP105CA** (A: NO)

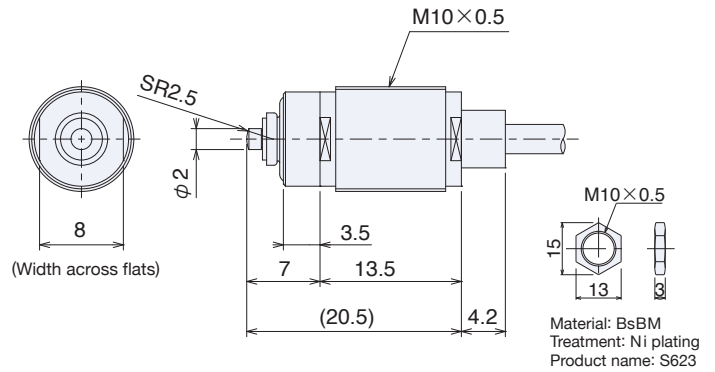

Material: BsBM  
Treatment: Ni plating  
Product name: S623

**Options**

Standard product	LED indicator
Core-wire cable <b>CSM105WA</b>	<b>Blank:</b> No LED
Cabtyre cable <b>CSM105CA</b> <b>CSMP105CA</b>	<b>L:</b> 120mm from the switch *Only for cabtyre cable

Transistor output	
Only for cabtyre cable	
<b>TNA</b>	Added to standard product name
<b>TNB</b>	
<b>TPA</b>	
<b>TPB</b>	
(Refer to P7-3)	

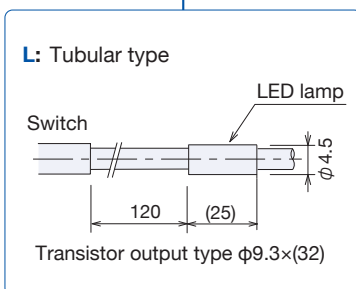

- ▶ e.g.) **CSM105CA-L**
- ▶ Transistor output e.g.) **CSM105CATNA**

**How to use**

Make contact with detected objects at right angle (within deflection angle  $\pm 3^\circ$ )

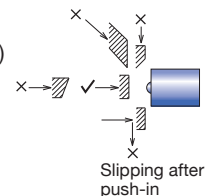

Do not press the plunger to the stroke end. It may cause malfunction due to the impact.

If there is a possibility to press the plunger to the stroke end, install a stopper separately to prevent the malfunction.

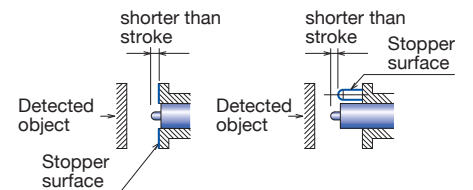

**Circuit diagram**

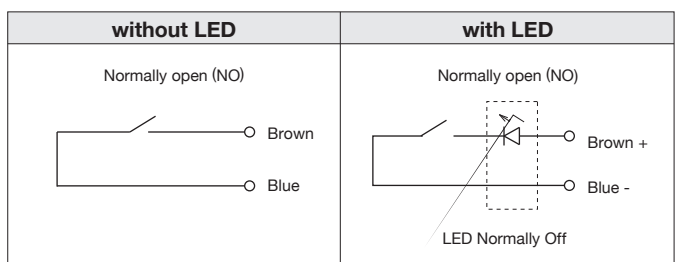

Electrical specification / circuit diagram. (Refer to P7-2)

**When using the switches with LED option, limit the current below 10mA.**(Refer to P14-3 "Confirmation of switch operation")

# Machine Components with a **BUILT-IN SWITCH** SERIES

## ■ Stopper Bolt Switch



## ■ Mini Stopper Switch

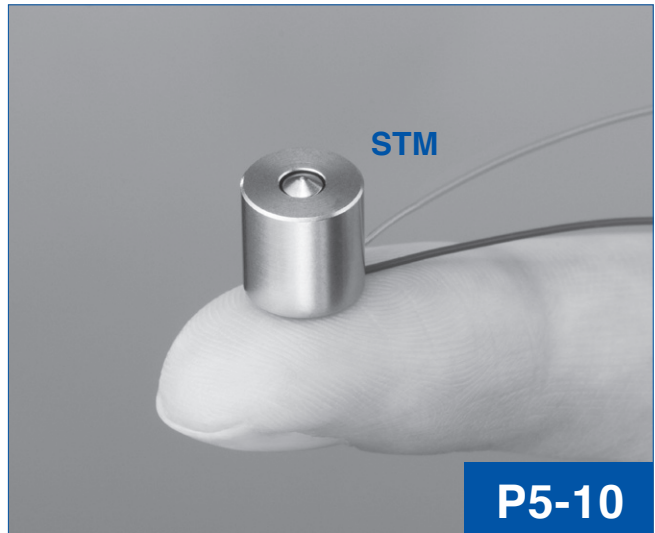

## ■ Ball Plunger Switch

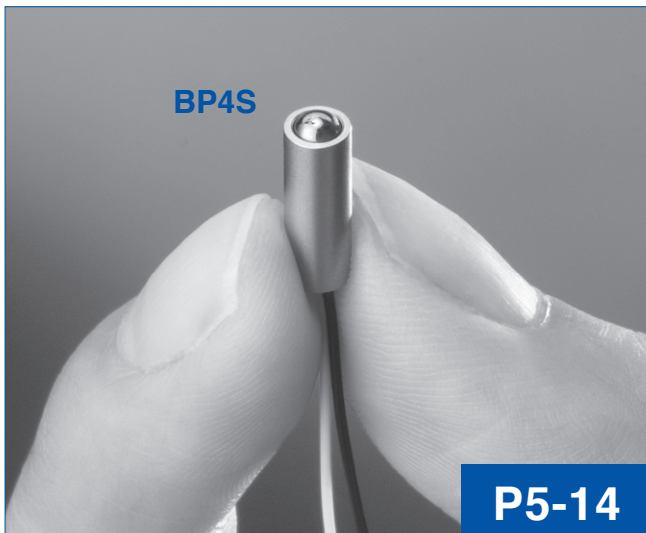

## ■ Spring Plunger Switch



## Stopper Bolt Switch

- 2 tasks with one device  
Housing a high-accuracy built-in switch in a stopper bolt
- The built-in switch is cartridge type
- For downsizing and cost-saving the machine

· Straight touch type (Metal bearing)

**STS / STE / STP** ..... P5-4

## Mini Stopper Switch

- $\phi 8 \times 8$  Mini-stopper with a built-in switch

· Mini type

**STM** ..... P5-10

## Ball Plunger Switch

- Housing a built-in switch in a ball plunger

· Indexing check / Sliding touch type (Contacting ball type)

**BP** ..... P5-14

## Spring Plunger Switch

- Housing a built-in switch in a spring plunger

· Knocking out check type (Metal bearing)

**SP** ..... P5-18

# MACHINE COMPONENTS WITH A BUILT-IN SWITCH

## Selection by how to touch the objects

### Stopper Bolt Switch

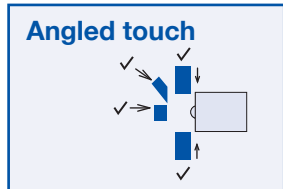
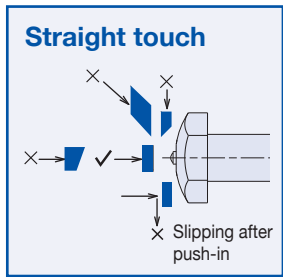

### Ball Plunger Switch

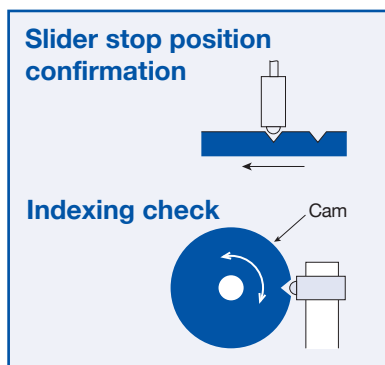

### Spring Plunger Switch

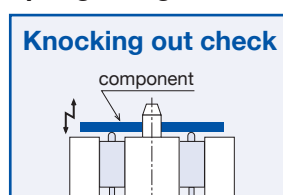

- Size: M6 / M8 / M10
- The built-in switch is cartridge type



- Size: M6 / M8 / M10
- The built-in switch is cartridge type



- Protective structure IP67
- The built-in switch is cartridge type



- $\phi 8 \times 8$  (the smallest) Mini type
- Protective structure IP67



- The ball rolls over Contacting ball type



- Size:  $\phi 4$  / M5
- Housing a built-in switch in a ball plunger



- Size: M6
- Housing a built-in switch in a ball plunger



- Housing a built-in switch in a spring plunger

Product list

unit:mm

	Output mode	Standard product name	Protective structure	Size	Page	
 <b>Stopper Bolt Switch</b>	A : Normally open B : Normally close	STS060PA / STS060PB	IP65	M6×1	Straight bolt type	P5-4
		STS080PA / STS080PB		M8×1.25		
		STS100PA / STS100PB		M10×1.5		
		STE060PA / STE060PB		M6×1	Hexagonal bolt type	
		STE080PA / STE080PB		M8×1.25		
		STE100PA / STE100PB		M10×1.5		
		STP080UA / STP080UB	IP67	M8×1.25	Waterproof type with upward a protective cover	
		STP100UA / STP100UB		M10×1.5		
		STP080DA / STP080DB		M8×1.25	Water-resistant type with downward a protective cover	
		STP100DA / STP100DB		M10×1.5		

 <b>Mini Stopper Switch</b>	Short type/Core-wire cable A : Normally open	STM11A	IP44	φ8×8	Non-threaded type	P5-10
		STM31A		M10×8	Threaded type	
		STMB11A		φ8×11	Non-threaded type (contacting ball)	
		STM35A		M10×11	Threaded type (contacting ball)	
		STM12A		IP44	φ8×15	
	Long type/Cable type A : Normally open	STM62A	IP67	φ9×18.5	Threaded type	
		STM32A	IP44	M10×15		
		STM82A	IP67	M10×19.5	Non-threaded type (contacting ball)	
		STMB12A	IP44	φ8×18		
		STM36A		M10×18		

<b>Ball Plunger Switch</b>	A : Normally open	BP4SWA	IP40	φ4	Indexing output	P5-14
		BP5MWA		M5×0.5		
	A : Normally open	BP060A	IP40	M6×1	Indexing output	P5-16

<b>Spring Plunger Switch</b>	A : Normally open	SP060A	IP40	M6×1	Knocking out check	P5-18
		SP080A		M8×1.25		

# Stopper Bolt Switch

Machine Components with a Built-in Switch series  
www.metrol.co.jp/en

## STS / STE / STP

Seating check, plunger type  
**Straight touch type (Metal bearing)**

PAT.PEND.

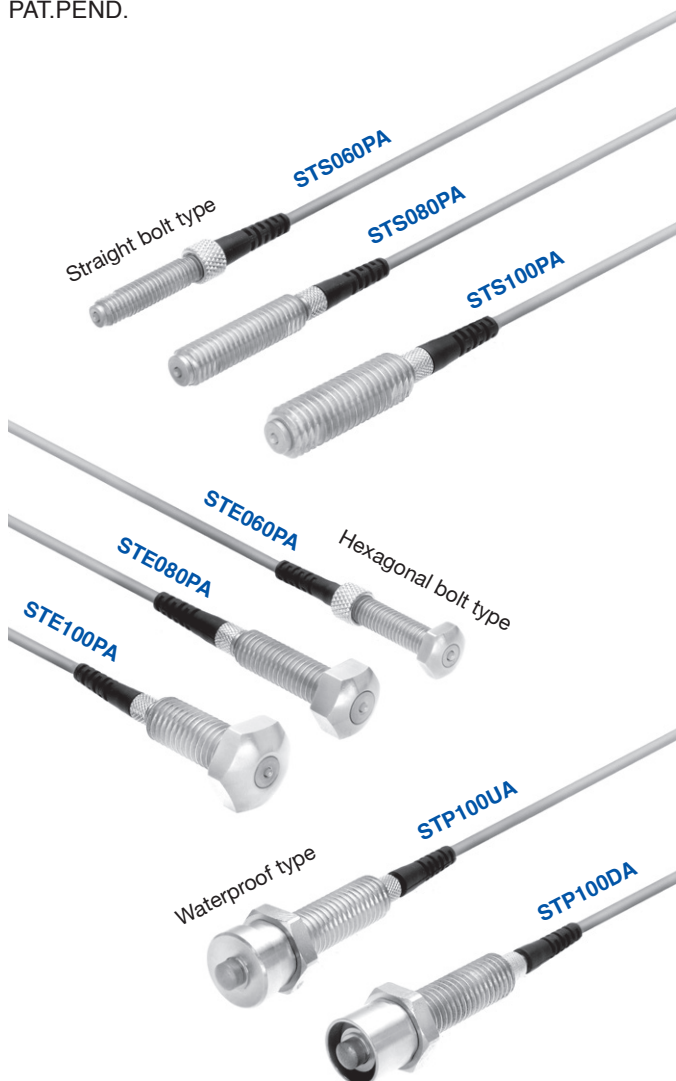

### Features

- **2 tasks with 1 device.**  
Housing a high-accuracy built-in switch in a stopper bolt.

Compact machine size by reducing the number of parts.

\*Use Air Gap Sensor(P2-1), for precision seating confirmation.

### Differences from conventional switches

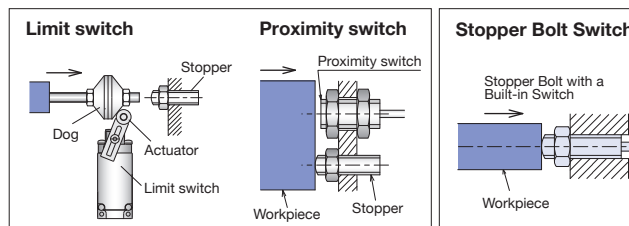

No need of dogs and stopper bolts → Compact machine design

- **Maintenance cost is greatly reduced by applying cartridge type.**

When replacing the switch because of breakdown, no need for detaching the stopper bolt or adjusting the position of it, thereby simplifying the maintenance procedure.





No need to visit customer sites for repair

Install stopper bolt and adjust the position before installing the built-in type switch to avoid the twisting of the cable.



### Standard specification

unit:mm

Shape	Product name	Output mode	Size	Protective structure	with LED	Cartridge name
Straight bolt type		A: Normally open B: Normally close	M6×1	IP65	STS060P A / B- L	KS21PA / KS21PB
			M8×1.25		STS080P A / B- L	
			M10×1.5		STS100P A / B- L	
Hexagonal bolt type		A: Normally open B: Normally close	M6×1	IP65	STE060P A / B- L	KS21PA / KS21PB
			M8×1.25		STE080P A / B- L	
			M10×1.5		STE100P A / B- L	
Water-proof type	with upward protective cover 	A: Normally open B: Normally close	M8×1.25	IP67	STP080U A / B- L	KS30A / KS30B
			M10×1.5		STP100U A / B- L	
	with downward protective cover 		M8×1.25		STP080D A / B- L	
			M10×1.5		STP100D A / B- L	

e.g.) STS060PA

-L: LED indicator (120mm from the switch)



## Common specification

unit:mm

Switch structure	Dry contact
Output mode	A: Normally open / B: Normally close
Signal point	0.3 from stopper surface*1
Stroke	0.7
Repeatability	Both On→Off, Off→On/ 0.01 (range) (At operating speed 50-200mm/min) *2
Movement differential	0
Contact life time	10 million (No bungle caused by vibration and use under contact rating)
Contact force	STS / STE: 2N STP: 4N
Contacting part material	SUS HRC40-50
Hardness of the stopper surface	SUS HRC40-50

Withstand load	5000N
Impact resistance	0.4J
Cable (Refer to P7-5)	Standard length 2m Oil resistant $\phi 2.8 / 2$ cores, Tensile strength 30N, minimum bending R7 Cable protector (Detachable)
Operating temperature range	0°C-80°C (Ice-free) *3
Temperature drift	0 (because of no amplifier)
Vibration	10-55Hz total amplitude 1.5 for X,Y,Z each direction
Shock	300m/s <sup>2</sup> for X,Y,Z each direction
Contact rating (Refer to P14-3)	DC5V-DC24V Steady current : 10 mA or less (rush current: 20 mA or less) <b>When using the switch with LED, limit the current below 10mA.</b>
Standard accessory	Two fixing nuts and a toothed washer

\*1 Refer to the following.

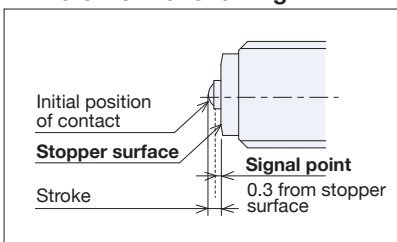

\*2 Operating speed slower than 10mm/min is not recommended.

\*3 The sealed waterproof structure causes delay in return, when used under temperature (below 5°C).

☉The following options are available.

- Transistor output (Refer to P7-3)
- Reverse connect protection.
- Level conversion.
- Output current is increased to 100mA.

## Outer dimension

### Straight bolt type

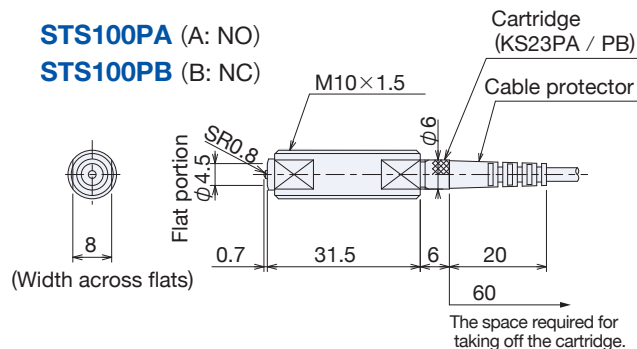
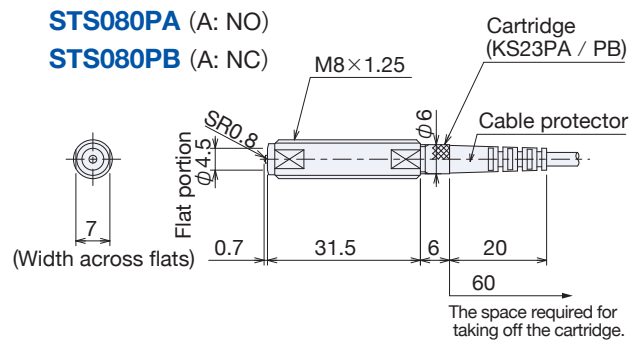
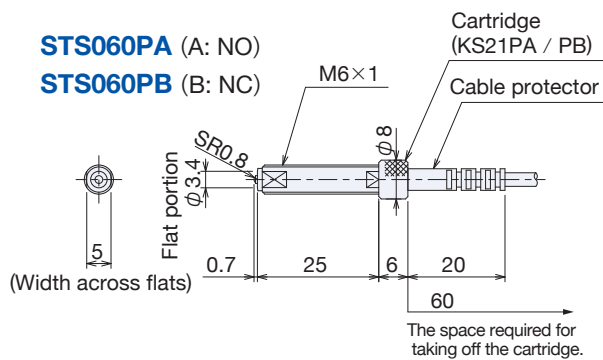

Drawing of cartridge

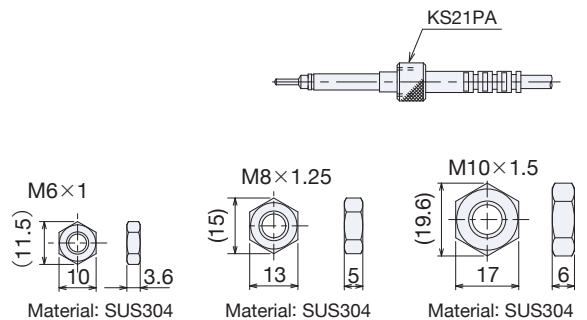



Outer dimension

Hexagonal bolt type

**STE060PA** (A: NO)  
**STE060PB** (B: NC)

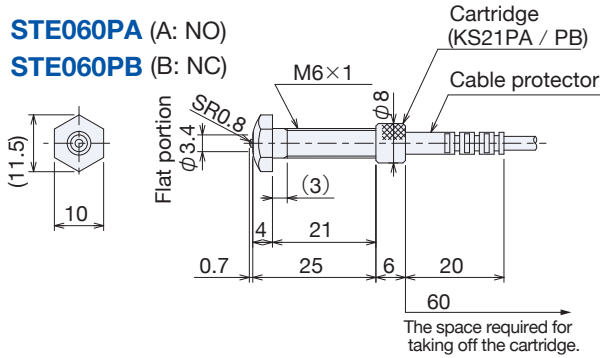

**STE080PA** (A: NO)  
**STE080PB** (B: NC)

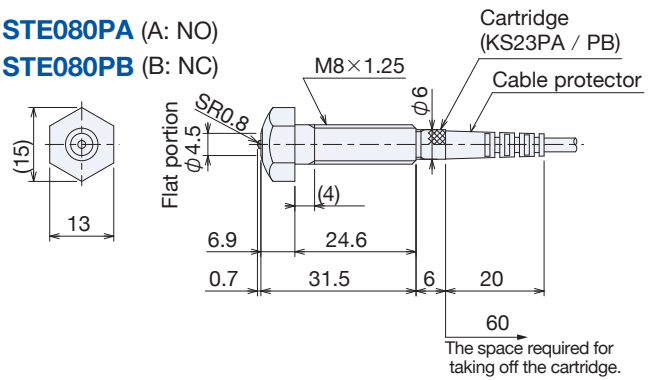

**STE100PA** (A: NO)  
**STE100PB** (B: NC)

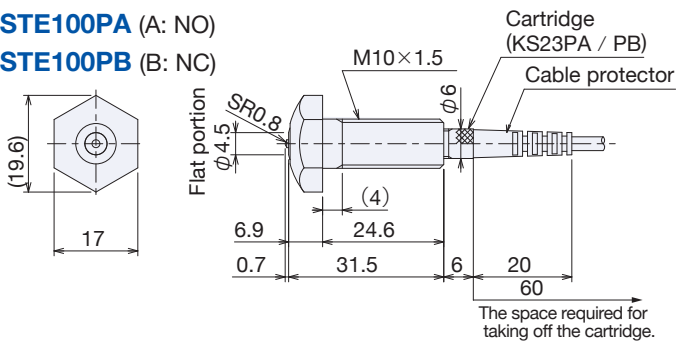

LED indicator(-L)

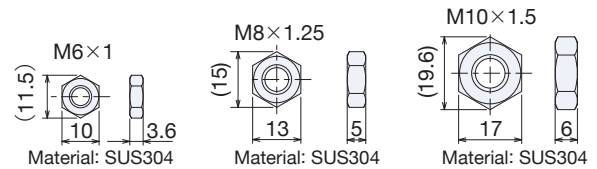
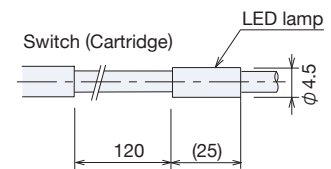

Waterproof type (IP67)

with upward protective cover

**STP080UA** (A: NO)  
**STP080UB** (B: NC)

**STP100UA** (A: NO)  
**STP100UB** (B: NC)

STP080U : M8 x 1.25  
STP100U : M10 x 1.5

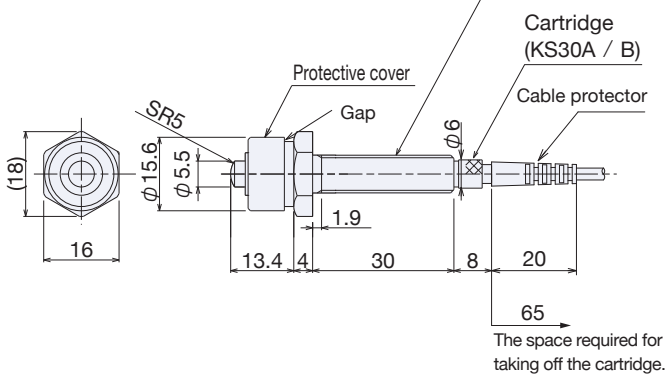

with downward protective cover

**STP080DA** (A: NO)  
**STP080DB** (B: NC)

**STP100DA** (A: NO)  
**STP100DB** (B: NC)

STP080U : M8 x 1.25  
STP100U : M10 x 1.5

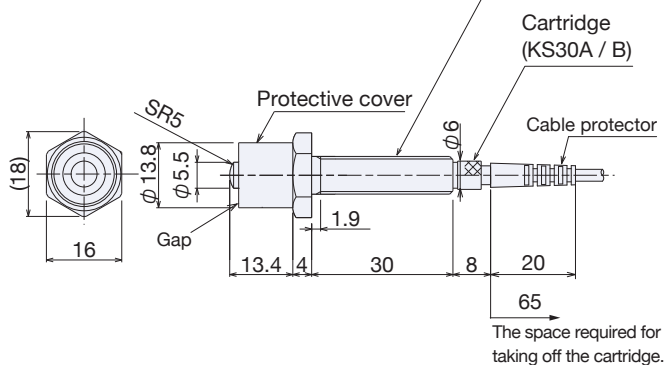

## Options

Product name		LED indicator
<b>Straight bolt type</b> STS060P A / B STS080P A / B STS100P A / B	<b>Waterproof type</b> with upward protective cover STP080U A / B STP100U A / B	<b>Blank:</b> No LED  <b>L:</b> 120mm from the switch
<b>Hexagonal bolt type</b> STE060P A / B STE080P A / B STE100P A / B	with downward protective cover STP080D A / B STP100D A / B	

Transistor output	
<b>TNA</b> <b>TNB</b> <b>TPA</b> <b>TPB</b>	Added to standard product name  (Refer to P7-3)

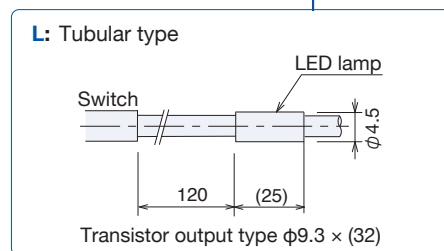

- ▶ e.g.) STS060PA-L
- ▶ Transistor output e.g.) ST060PATNA

## Tightening torque for case screws and nuts

Applicable models	Tightening torque	
	L1 : 5N·m	L2 : 2.5N·m
STS060PA / B	L1 : 5N·m	L2 : 2.5N·m
STE060PA / B		
STS080PA / B	10N·m	
STE080PA / B		
STP080UA / B		
STP080DA / B		
STS100PA / B	25N·m	
STE100PA / B		
STP100UA / B		
STP100DA / B		

STS060PA / B

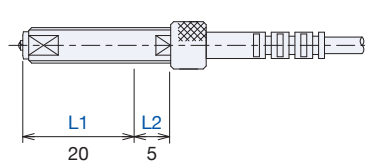

STE060PA / B

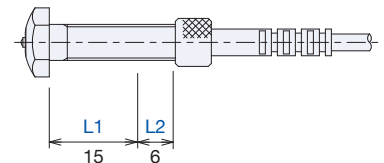

### Caution

Use the lower torque (i.e. torque corresponding to L2) while tightening the bolt between the lengths L1 and L2 in the above picture. Please make sure to use a locknut if the bolt is likely to shift in position due to the vibrational impacts.

**How to use**

Make contact with the detected object at right angle (with deflection angle  $\pm 3^\circ$ )

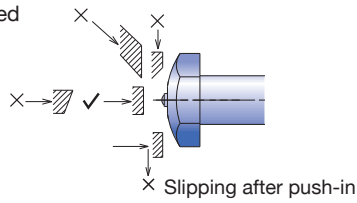

**Circuit diagram**

without LED	with LED
<p>Normally open (NO)</p>	<p>Normally open (NO)</p>
<p>Normally close (NC)</p>	<p>Normally close (NC)</p>

Electrical specification / circuit diagram. (Refer to P7-2)

**When using the switches with LED option, limit the current below 10mA.** (Refer to P14-3 "Confirmation of switch operation")

**How to fix the switch**

Simply screw in (No need for position setting)

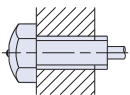

Screw in to the mounting hole and apply a lock nut \*

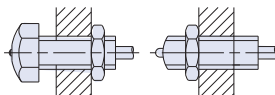

Insert the switch in the mounting hole and apply two fixing nuts \*

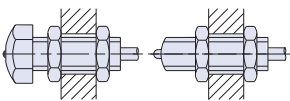

\* Use level 2 bracket screw, and note the increase of impact resistance.

**Impact-resistance calculation**

**Inertia collision**

$E = mv^2/2$   
 m: Mass kg  
 v: Speed m/s

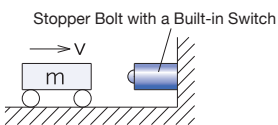

e.g.)

m	v	$mv^2/2$ [J]
80	0.1	0.4
320	0.05	0.4
80	0.05	0.1

**Vertical free fall**

$E = mgh$   
 g: Gravitational acceleration 9.8m/s<sup>2</sup>  
 h: Dropping height m

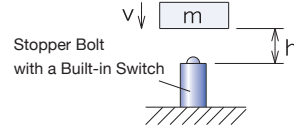

e.g.)

m	h	$v = \sqrt{2gh}$	$mgh$ [J]
0.4	0.05	1	0.2
0.4	0.1	1.4	0.4

**Protective covers** (Only for Water-resistant type)

Choose the suitable cover according to switch mounting direction so that the metal cuttings and coolant can't enter from the gaps. (Refer to P14-5)

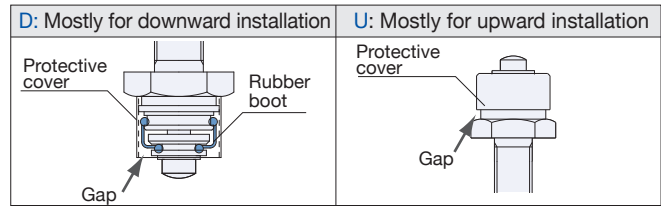

**For metal cuttings and coolant**

- Protective cover is strongly recommended to avoid damage from cuttings and coolant when the switch is used in machining environment. In addition, an extra cover is recommended to avoid direct hit by high-pressure coolant or heavy cuttings.
- For horizontal mounting, an extra cover prevents coolant or cuttings from entering inside and getting piled up on the body.
- Fabricate and place an extra cover to avoid metal chips adhering to the rubber boots during the grinding operation.

**Precautions for installing cartridge**

- When the cartridge is delivered, locking coating is applied to the screw, which is tightened lightly. Tighten the nuts with fingers to optimize the locking agent.
- Tighten the cartridge firmly by fingers. Do not use pliers to fix it. That may cause malfunction.
- The cartridge is thin. Carefully handle it.
- When installing the cartridge type switch, give considerable space to replace the cartridge.



# Mini Stopper Switch

Machine Components with a Built-in Switch series

www.metrol.co.jp/en

# STM

Seating check plunger type

## Mini type

US.PAT.

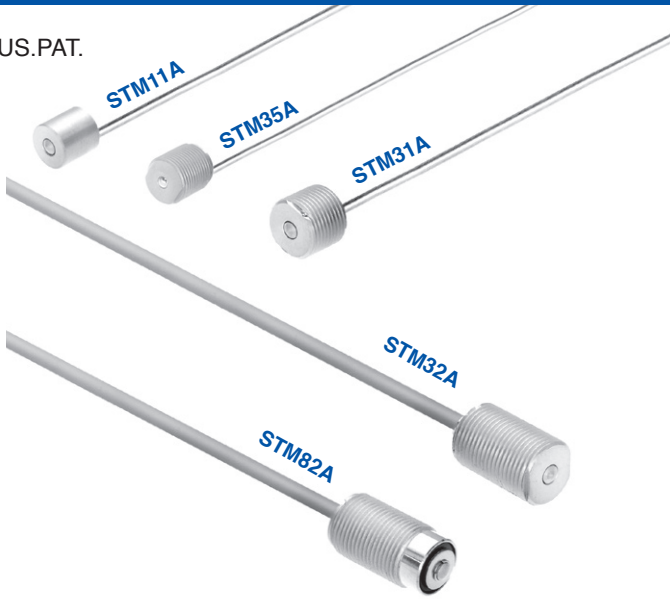

### Features

- $\phi 8 \times 8$  Smallest size
- Mini switch with a hardened stopper surface
- Best suited to demanding application and equipment for installation space.
- There are straight touch type and angled touch type.

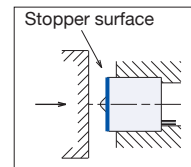
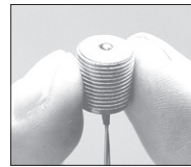

- Friction-less plate spring is applied to this product
- As for waterproof type, the stopper surface is stored in the rubber boot.
- High dimensional accuracy for mounting simple setting at replacement.

### Standard specification

unit:mm

Shape	Product name	Protective structure	Contact force	Size	Stroke	with LED
Short type core-wire cable	Non-threaded type straight touch <b>STM11A</b>	IP44	0.8N	$\phi 8 \times 8$	0.5	
	Threaded type straight touch <b>STM31A</b>	IP44	0.8N	M10 $\times$ 8	0.5	
	Non-threaded/ threaded with a contacting ball type angle touch <b>STMB11A</b> <b>STM35A</b>	IP44	0.8N	$\phi 8 \times 11$ M10 $\times$ 11	0.5	
Long type cabtyre cable	Non-threaded type straight touch <b>STM12A</b>	IP44	0.8N	$\phi 8 \times 15$	0.5	<b>STM12A-L</b>
	Non-threaded type straight touch <b>STM62A</b>	IP67	1N	$\phi 9 \times 18.5$	0.3	<b>STM62A-L</b>
	Threaded type straight touch <b>STM32A</b>	IP44	0.8N	M10 $\times$ 15	0.5	<b>STM32A-L</b>
	Threaded type straight touch <b>STM82A</b>	IP67	1N	M10 $\times$ 19.5	0.3	<b>STM82A-L</b>
	Non-threaded/ threaded with a contacting ball type angle touch <b>STMB12A</b> <b>STM36A</b>	IP44	0.8N	$\phi 8 \times 18$ M10 $\times$ 18	0.5	<b>STMB12A-L</b> <b>STM36A-L</b>

○When stopper property is not required,  
CS-Touch Switch CSM with 1.5mm stroke is recommended. (Refer to P4-13)

-L : LED indicator (120mm from the switch)

### Common specification

unit:mm

Switch structure	Dry contact
Output mode	A : Normally open
Signal point	Middle of the stroke
Repeatability	Both On→Off, Off→On/ 0.01 (range) (At operating speed 50~200mm/min) *1
Movement differential	0
Contact life time	10 million (No bungle caused by vibration and use under contact rating)
Withstand load	3000N 1500N : In the case the contacting surface of the detected object is smaller than $\phi 6$ and the selected switch is IP44 (STM11-STM36)
Impact resistance	0.2J
Case and stopper surface material	SUS HRC45
Contacting part material	SUS HRC50-

Cable (Refer to P7-5)	Short type: Core-wire cable 0.5m( $\times$ 2) Oil-resistant $\phi 0.6$ Tensile strength 15N Long type: Cabtyre cable 2m Oil-resistant $\phi 2.8 / 2$ cores, Tensile strength 30N
Operating temperature range	0°C-80°C (Ice-free)*2
Temperature drift	0 (because of no amplifier)
Vibration	10-55Hz total amplitude 1.5 for X,Y,Z each direction
Impact	300m/s <sup>2</sup> for X,Y,Z each direction
Contact rating (Refer to P14-3)	DC5V-DC24V Steady current : 10 mA or less (rush current: 20 mA or less) <b>When using the switch with LED, limit the current below 10mA.</b>
Standard accessory	Refer to Outer dimension(P5-11)

\*2 The sealed waterproof structure causes delay in return,  
when used under temperature (below 5°C).

○The following options are available.

- Transistor output (Refer to P7-3)
- LED indicator
- Reverse connect protection.
- Cable direction
- Level conversion.
- Heat-resistance (P6-4)
- Output current is increased to 100mA.

\*1 Operating speed slower than 10mm/min is not recommended.

Outer dimension Straight touch type **Short type (Core-wire cable)**

Mini Stopper Switch

Drip-proof type (IP44)	
Non-threaded type	<p><b>STM11A (A: NO)</b></p>
Threaded type	<p><b>STM31A (A: NO)</b></p> <p>Material : BsBM Treatment : Ni plating Product name : S623B</p> <p>Accessory : Spanner × 1, nut × 1</p>

Options

<p><b>Product name</b></p> <p>STM series</p>	<p><b>LED indicator</b></p> <p>Blank: No LED Only long type (cabtyre cable) L: 120mm from the switch</p>
<p><b>Transistor output</b></p> <p>Only for long type (cabtyre cable)</p> <p>TNA Added to standard product name TNB TPA TPB</p> <p>(Refer to P7-3)</p> <p>▶ e.g.) STM12A-L ▶ Transistor output e.g.) STM12ATNA</p>	<p>L: Tubular type</p>

Outer dimension Straight touch type **Long type (Cabtyre cable)**

Drip-proof type (IP44)		Waterproof type (IP67)	
Non-threaded type	<p><b>STM12A (A: NO)</b></p>	Non-threaded type	<p><b>STM62A (A: NO)</b></p>
Threaded type	<p><b>STM32A (A: NO)</b></p> <p>Accessory : Spanner × 1, nut × 2, toothed washer</p>	Threaded type	<p><b>STM82A (A: NO)</b></p> <p>Accessory : nut × 2, toothed washer</p>

(-L) Refer to below for LED indicator

Outer dimension Angled touch type **Contacting ball (IP44)**

Short type (Core-wire cable)		Long type (Cabtyre cable)	
Non-threaded type	<p><b>STMB11A (A: NO)</b></p>	Non-threaded type	<p><b>STMB12A (A: NO)</b></p>
Threaded type	<p><b>STM35A (A: NO)</b></p> <p>Accessory : Spanner × 1, nut × 1</p>	Threaded type	<p><b>STM36A (A: NO)</b></p> <p>Accessory : Spanner × 1, nut × 2, toothed washer</p>

## How to use

### Contacting ball type

Suitable for angular touch

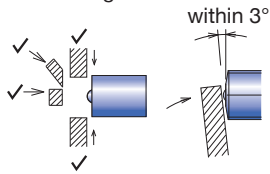

The angle required to turn on the switch when the object can not make contact with the switch end.

Do not press the plunger beyond the stopper.  
(The contact surface of the objects should be more than 3.5mm in diameter for drip-proof type)

### Other types

Make contact with the object at right angle (within deflection angle  $\pm 2^\circ$ )

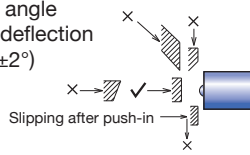

## Tightening torque for case screws and nuts

	Screw / Nut	Tightening torque	Applicable model
Mini Stopper Switch	M10	10N · m	STM

## Protective structure

### Drip-proof type (IP44)

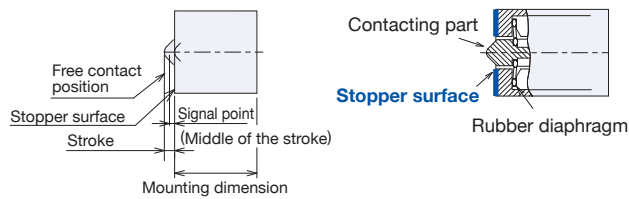

### Waterproof type (IP67)

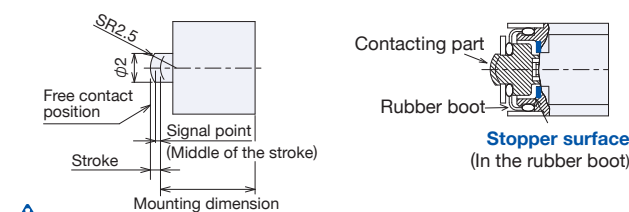

The products in this series are not suitable for operating in a harsh machining environment (even IP67 type) where coolant contains metal cuttings.

## Circuit diagram

without LED	with LED
<p>Normally open(NO)</p>	<p>Normally open(NO)</p>

Electrical specification / circuit diagram. (Refer to P7-2)

**When using the switches with LED option, limit the current below 10mA.** (Refer to P14-3 "Confirmation of switch operation")

## Stopper surface

1) When using under the specified static load resistance, the stopper surface of the product can be used as a stopper.

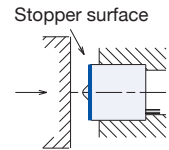

Do not let dust or metal cuttings pile up on the stopper surface when using drip-proof type

2) When the expected load is larger than the specification, embed the switch in a sturdy stopper (to be prepared by the customer) for use.

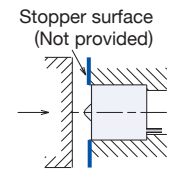

**Assembly: press fitting not allowed**

## How to install

### Non-threaded type

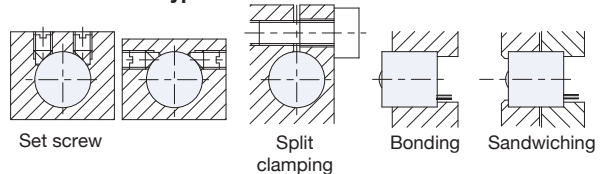

### Threaded type

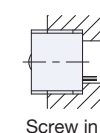





## BP4S / BP5M

1 signal plunger type (Contacting ball type)  
**Indexing check / sliding touch type**

**NEW**

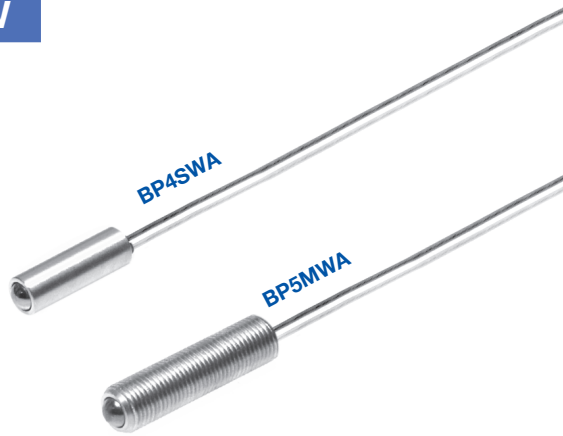

### Features

■ **Two functions in one, a touch switch built into the ball plunger.**

Able to provide identifying and positioning functions using notches on index rotating or sliding objects as well as output a confirmation signal.

Reduces the number of components and design manhours, allowing miniaturization of the machine.

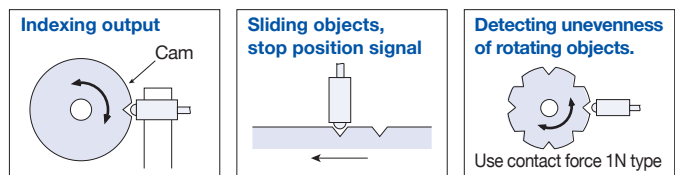

### Standard specification

Unit: mm

Product name	Size	Stroke	Contact force (axial direction)	Protective structure
<b>BP4SWA</b>	φ4	0.8	1N	IP40
<b>BP5MWA</b>	M5×0.5	1		

Switch structure	Dry contact
Output mode	A : Normally open
Pretravel	0.3
Repeatability	Both On→Off, Off→On/ 0.01 (range)(axial direction) (At operating speed 50-200mm/min)*
Movement differential	0
Contact life time	<b>BP4SWA</b> : 1 million <b>BP5MWA</b> : 3 million
Case material	SUS 303
Contact material	Tungsten carbide

Cable	Core-wire cable 0.5m×2 Oil resistant φ0.66 Tensile strength 15N
Operating temperature range	0°C-80°C (ice-free)
Temperature drift	0 (because of no amplifier)
Oscillation	10-55Hz total amplitude 1.5 for X,Y,Z each direction
Impact	300m/s <sup>2</sup> for X,Y,Z each direction
Contact rating	DC5V-DC24V Steady current : 10 mA or less (rush current: 20 mA or less)
Standard accessory	<b>BP5MWA</b> : Two fixing nuts

\*Operating speed slower than 10mm/min is not recommended.

### How to use

Suitable for sliding / angled touch

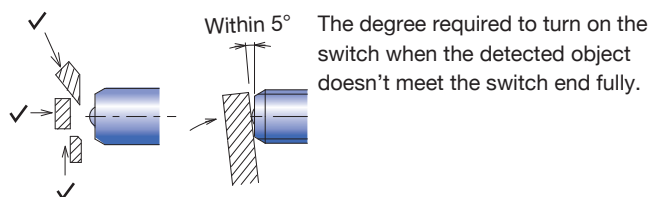

- When using for rotation indexing, adjust the position in consideration of eccentricity and core blurring accuracy of rotating objects.
- According to the operating circumstance, the signal point varies due to wear of the contacting part.
- Carefully calculate the angle and roughness of chamfer so that the contacting part is not easily worn off.
- Try not to bend the threaded part during installation. It will cause malfunction.

## Outer dimension

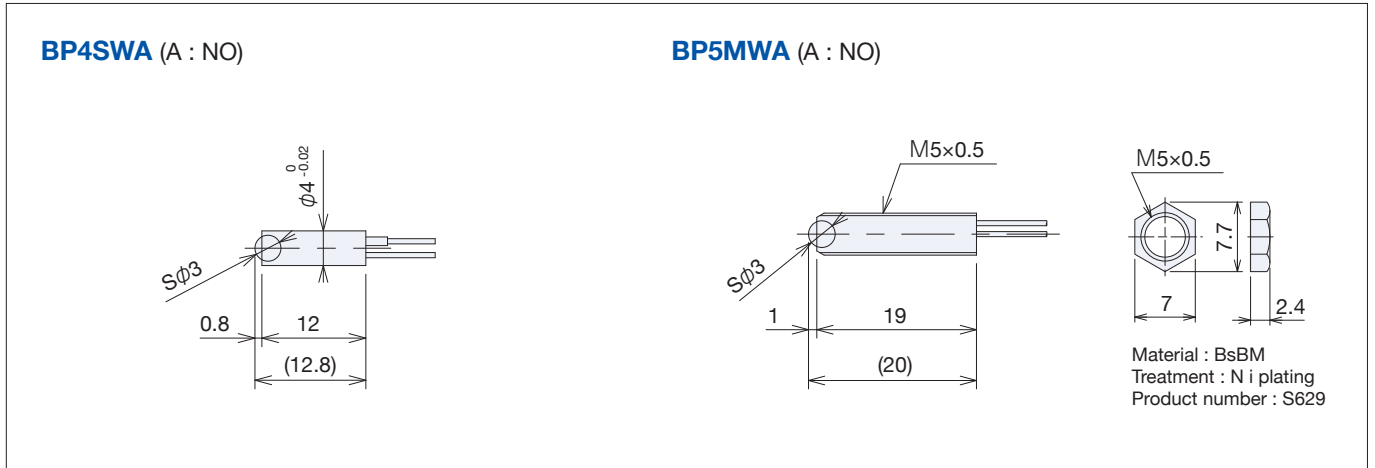

## Tightening torque for case screws and nuts

	Screw / Nut	Tightening torque	Applicable models
Ball Plunger Switch	Set screw*	0.1N·m or less	BP4SWA
	M5×0.5	1 N·m	BP5MWA

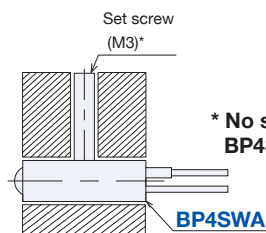

\* No set screws are provided with BP4SWA/BP5MWA.

## Circuit diagram

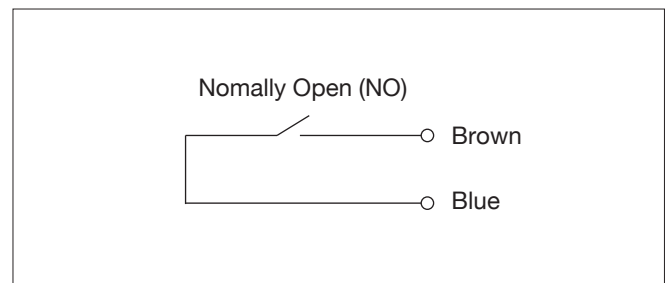

# Ball Plunger Switch

Machine Components with a Built-in Switch series

www.metrol.co.jp/en

# BP

1 signal plunger type (Contacting ball type)

## Indexing check / sliding touch type



### Features

■ **Two functions in one, a touch switch built into the ball plunger.**

Able to provide identifying and positioning functions using notches on index rotating or sliding objects as well as output a confirmation signal.

Reduces the number of components and design man-hours, allowing miniaturization of the machine.

■ **For customers selecting contact force of 1 N (-F)**

Please select CS-Touch Switch (refer to P4-3) in case of position or presence detection by straight travel contact and not for sliding.

◎ **CS-Touch Switch provides long stroke with small pre-travel making signal setting easy.**

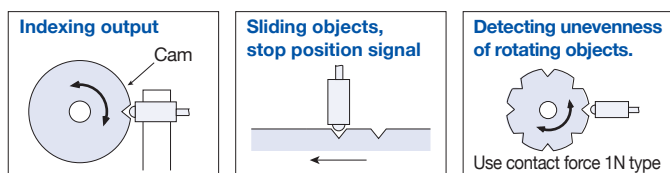

### Standard specification

#### Indexing check

unit: mm

Product name	Contact force(N) (axial direction)	with LED
<b>BP060A</b>	8N (max.13N)	<b>BP060A -L</b>

#### Sliding touch

unit: mm

Product name	Contact force(N) (axial direction)	with LED
<b>BP060A -F</b>	1	<b>BP060A -LF</b>

-F: Contact force 1N

-L: LED indicator (120mm from the sensor)

◎The edge surface has not been tempered. Do NOT use it as a stopper.

### Common specification

unit: mm

Switch structure	Dry contact	Cable	Standard length 2m Oil resistant $\phi$ 2.8 / 2 cores,
Output mode	A : Normally open	(Refer to P7-5)	Tensile strength 30N, minimum bending R7
Pretravel	0.3	Operating temperature range	0°C-80°C (Ice-free)
Stroke	0.8	Temperature drift	0 (because of no amplifier)
Repeatability	Both On→Off, Off→On/ 0.01 (At operating speed 50-200mm/min)*	Vibration	10-55Hz total amplitude 1.5 for X,Y,Z each direction
Movement differential	0	Shock	300m/s <sup>2</sup> for X,Y,Z each direction
Protective structure	IP40	Contact rating (Refer to P14-3)	DC5V-DC24V Steady current : 10 mA or less (rush current: 20 mA or less) <b>When using the switch with LED, limit the current below 10mA.</b>
Contact life time(Spring)	3 million	Standard accessory	Two fixing nuts and a toothed washer
Contact material	SUS 440 HRC 50-		
Case material	SUS 303		

\*Operating speed slower than 10mm/min is not recommended.

◎The following options are available.

· LED indicator

### Tightening torque for case screws and nuts

Applicable model	Tightening torque		
	L1	L2	L3
<b>BP060A</b>	2.5N·m	5N·m	2.5N·m

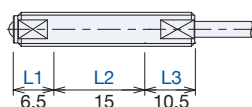

### Caution

Use the lower torque (i.e. torque corresponding to L1 and L3) while tightening the bolt between lengths L1 and L2 or L2 and L3 in the picture. Please make sure to use a locknut if the bolt is likely to shift in position due to the vibrational impacts.

Outer dimension

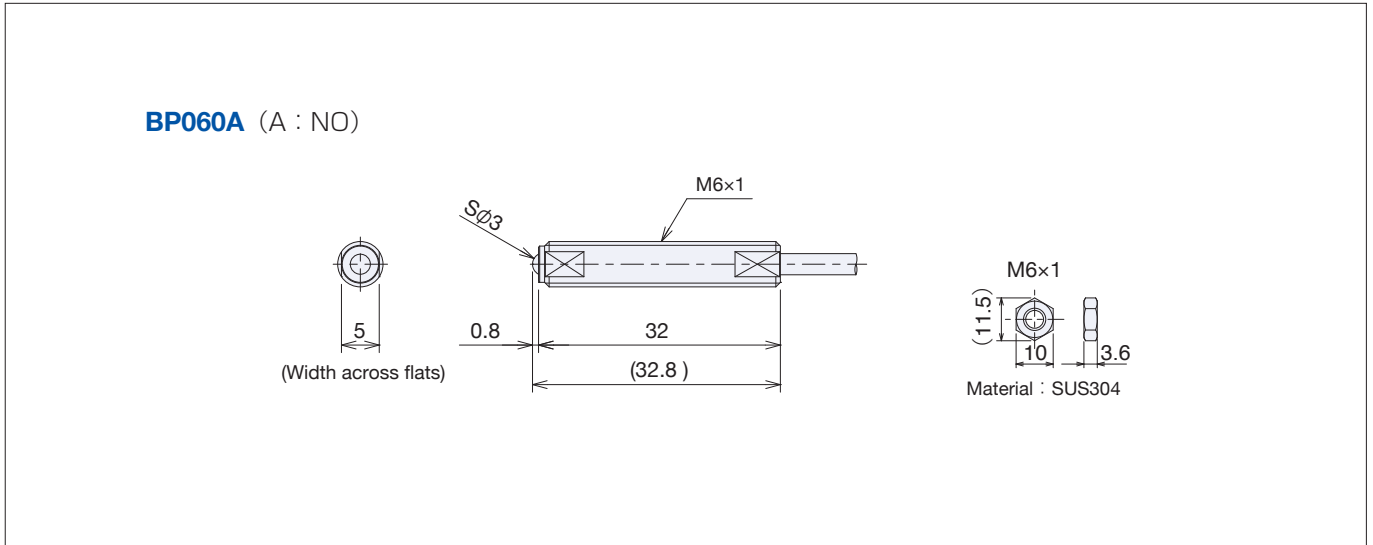

Options

Product name	LED indicator	Contact force
<b>BP060A</b>	<b>Blank:</b> No LED <b>L:</b> 120mm from the switch	<b>Blank:</b> Standard <b>F:</b> 1N

▶ e.g.) BP060A-L

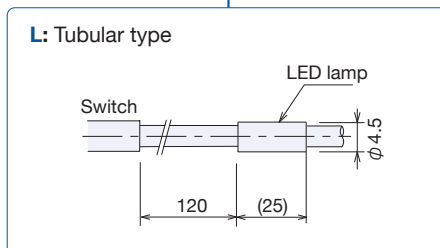

How to use

Suitable for angled touch

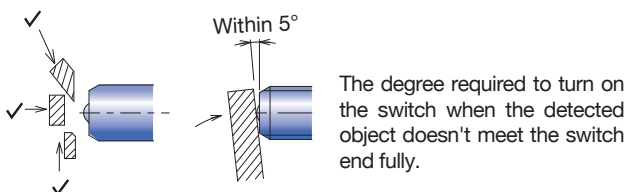

- When using for rotation indexing, adjust the position in consideration of eccentricity and core blurring accuracy of rotating objects.
- According to the operating circumstance, the signal point varies due to wear of the contacting part.
- Carefully calculate the angle and roughness of chamfer so that the contacting part is not easily worn off.
- Try not to bend the threaded part during installation. It will cause malfunction.

Circuit diagram

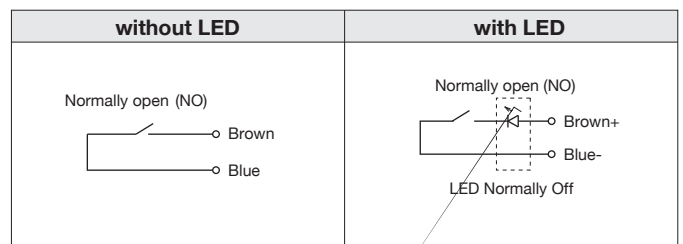

Electrical specification / circuit diagram. (Refer to P7-2)

**When using the switches with LED option, limit the current below 10mA.** (Refer to P14-3 "Confirmation of switch operation")



### Features

■ **Two functions in one, a touch switch built into the spring plunger.**

Reduces the number of components and design man-hours, allowing miniaturization of the machine.

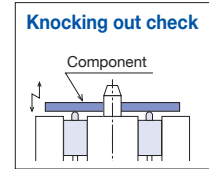

■ **Spring plunger with switch is dedicated for checking the ejection, with large movements till activation and little movement after activation.**

Please use CS-Touch Switch (refer to P4-3) for ordinary position detection without the ejection checking function.

(Large "clearance" in action after activation makes signal setting easier, no possibility of over-pressing damage.)

### Standard specification

unit: mm

Product name	Size	with LED
SP060A	M6×1	SP060A -L
SP080A	M8×1.25	SP080A -L

◎ Do not use the switch end as stopper.  
The end surface is not hardened.

-L : LED indicator (120mm from the sensor)

### Common specification

unit: mm

Switch structure	Dry contact
Output mode	A: Normally open
Pretravel	2.2
Stroke	3
Repeatability	Both On→Off, Off→On/ 0.01 (range) (At operating speed 50~200mm/min)*
Movement differential	0
Contact life time (Spring)	3 million
Protective structure	IP40
Contact force	8N (max. 11N)
Case material	SUS 303
Contacting part material	SUS HRC50-55

\*Operating speed slower than 10mm/min is not recommended.

Cable (Refer to P7-5)	Standard length 2m Oil resistant $\phi$ 2.8 / 2 cores, Tensile strength 30N, minimum bending R7
Operating temperature range	0°C-80°C (Ice-free)
Temperature drift	0 (because of no amplifier)
Oscillation	10-55Hz total amplitude 1.5 for X,Y,Z each direction
Impact	300m/s <sup>2</sup> for X,Y,Z each direction
Contact rating (Refer to P14-3)	DC5V-DC24V Steady current : 10 mA or less (rush current: 20 mA or less)  <b>When using the switch with LED, limit the current below 10mA.</b>
Standard accessory	Two fixing nuts and a toothed washer

◎ **The following options are available.**

·LED indicator

### Circuit diagram

without LED	with LED
Normally open (NO) Brown Blue	Normally open (NO) Brown+ Blue- LED Normally Off

Electrical specification / circuit diagram. (Refer to P7-2)

**When using the switches with LED option, limit the current below 10mA.** (Refer to P14-3 "Confirmation of switch operation")

### How to use

Make contact with detected object at right angle.  
(within deflection angle  $\pm 3^\circ$ )

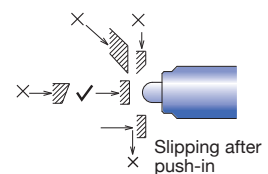

Outer dimension

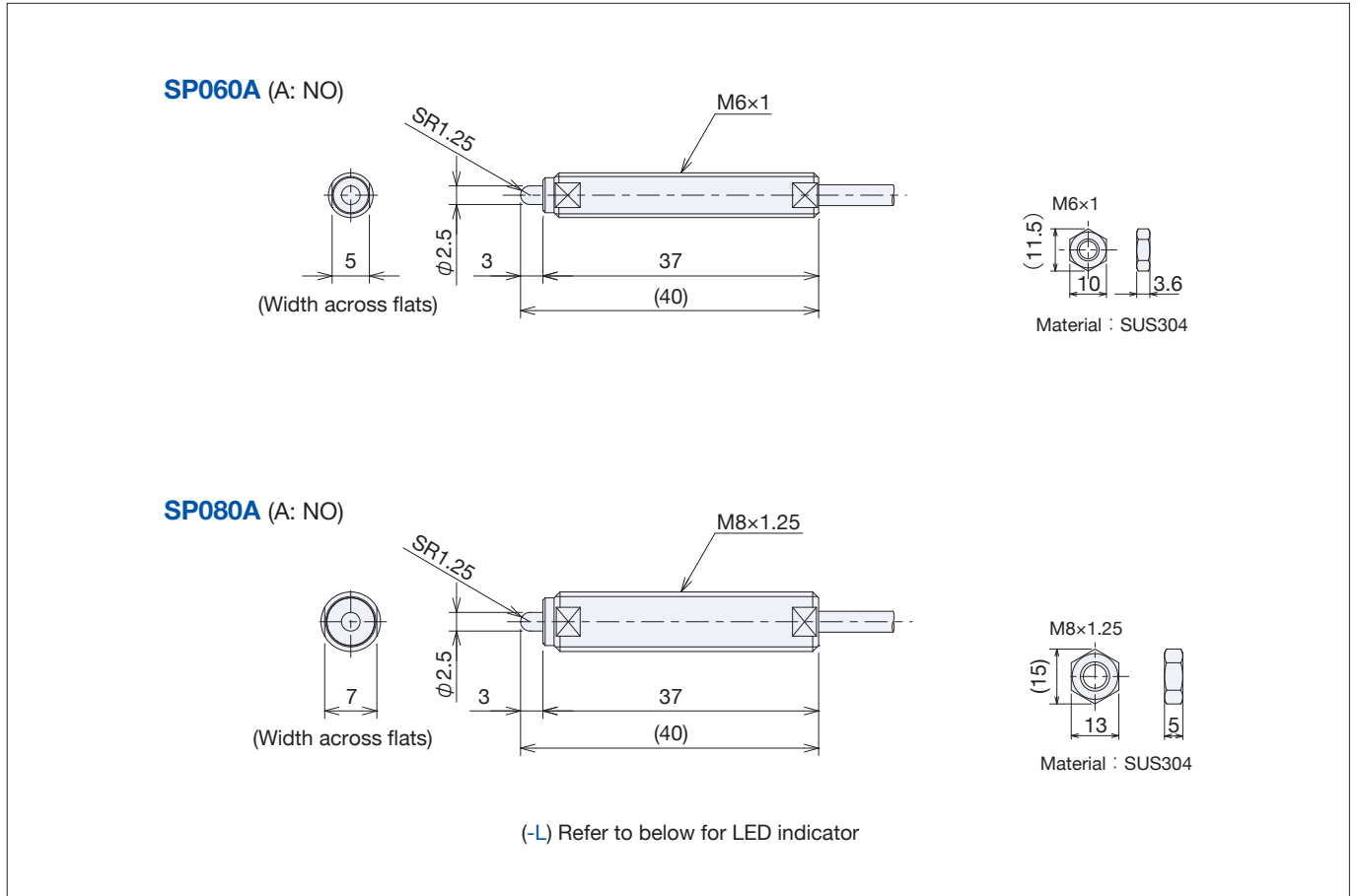

Options

Product name	LED indicator
SP060A SP080A	<b>Blank:</b> No LED <b>L:</b> 120mm from the switch

▶ e.g.) SP060A-L

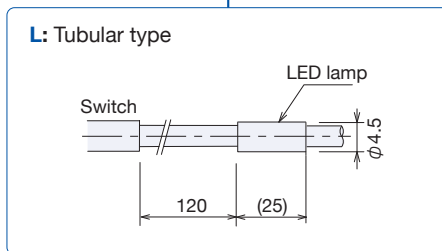

Tightening torque for case screws and nuts

Applicable models	Tightening torque	
	L1	L2
SP060A	5N·m	2.5N·m
SP080A	10N·m	5N·m

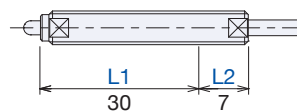

Caution

Use the lower torque (i.e. torque corresponding to L2) while tightening the bolt between the lengths L1 and L2 in the above picture. Please make sure to use a locknut if the bolt is likely to shift in position due to the vibrational impacts.



# SPECIAL PURPOSE SWITCH SERIES

## Low contact force Switch



## Heat resistance Switch



## High-vacuum resistance Switch

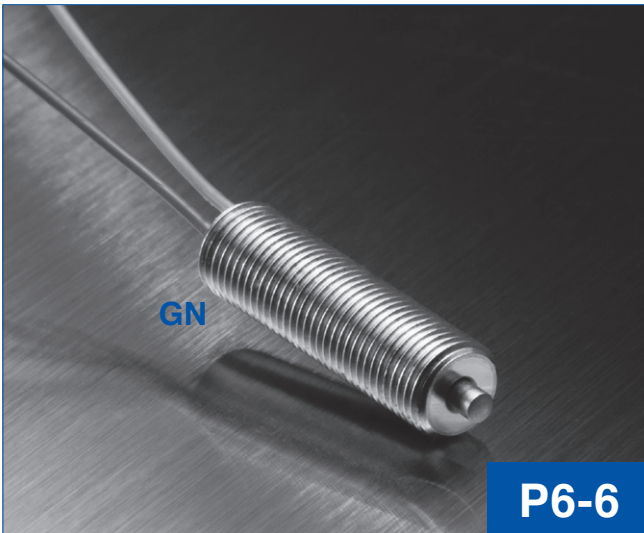

## Low contact force Switch

### ■ Contact force 0.1N

Low contact force avoid workpieces, such as semiconductors and ceramic tools, from being damaged.

**CSF** ..... P6-2

## Heat resistance Switch

### ■ Operating upper limit temperature 200°C

Be made of heat resistance parts / adhesives for a high temperature / heat resistance cord.

**HT series** ..... P6-4

## High-vacuum resistance Switch

### ■ Supports high degree of vacuum of $10^{-5}$ Pa

Adopts materials, adhesives and wiring supporting low out gas.

**GN series** ..... P6-6

# Low contact force Switch

Special purpose switch series

www.metrol.co.jp/en

# CSF

1 signal plunger type

**Contact force 0.1N type (Metal bearing)**



## Features

### 0.1N Low contact force

Realizes low contact force similar to non-contact type without limit, by using a non-contact circuit in the built-in switch.

(Due to use of amplifier, however, there remains the disadvantage of hysteresis and temperature drift compared with contact type)

Example) Detection of presence of semiconductors, ceramic tools, and minute parts, etc.

### 《Application》

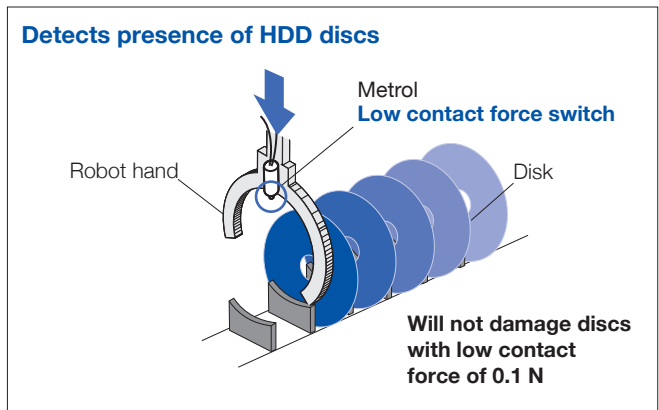

## Standard specification

Product name	Size	Contact force
CSFN105A	M10×0.5	0.1N
CSFSN10A	φ10	

## Common specification

Switch structure	Contact-less
Output mode	A: NO
Pretravel	0.4
Stroke	2
Repeatability	0.01 (range)
Movement differential	0.03
Protective structure	IP40
Case material	SUS303
Contacting part material	SUS303, φ2 plunger SR1.5

Cable	Standard length 3m Oil resistant φ4/ 3 cores, Tensile strength 30N Minimum bending R7
Operating temperature range	0°C-60°C (Ice free)
Temperature drift	0.03/10-40°C MAX
Oscillation	10-55Hz total amplitude 1.5 for X, Y, Z each direction
Impact	300m/s <sup>2</sup> X,Y,Z each direction
Output capacity	DC12V-DC24V 10mA (MAX) Resistance load
Output specification	NPN Open collector
Standard accessory	Two fixing nuts for threaded type

unit: mm

### ◎The following options are available.

- Transistor output (Refer to P7-3)
- Reverse connect protection.
- Level conversion.
- Output current is increased to 100mA.
- Shape of contacting part
- LED indicator
- Mounting direction

## How to use

Make contact with detected object at right angle (within deflection angle ±3°).

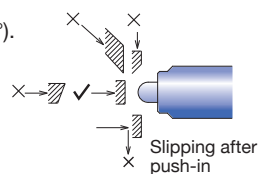

## Circuit diagram

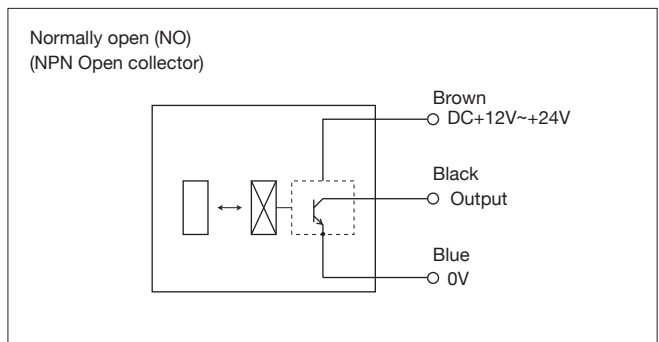

Electrical specification / circuit diagram

**Always make sure to turn off the power before installing or removing switches.** (Refer to P7-3 "Precautions for switch connection")

**Outer dimension**

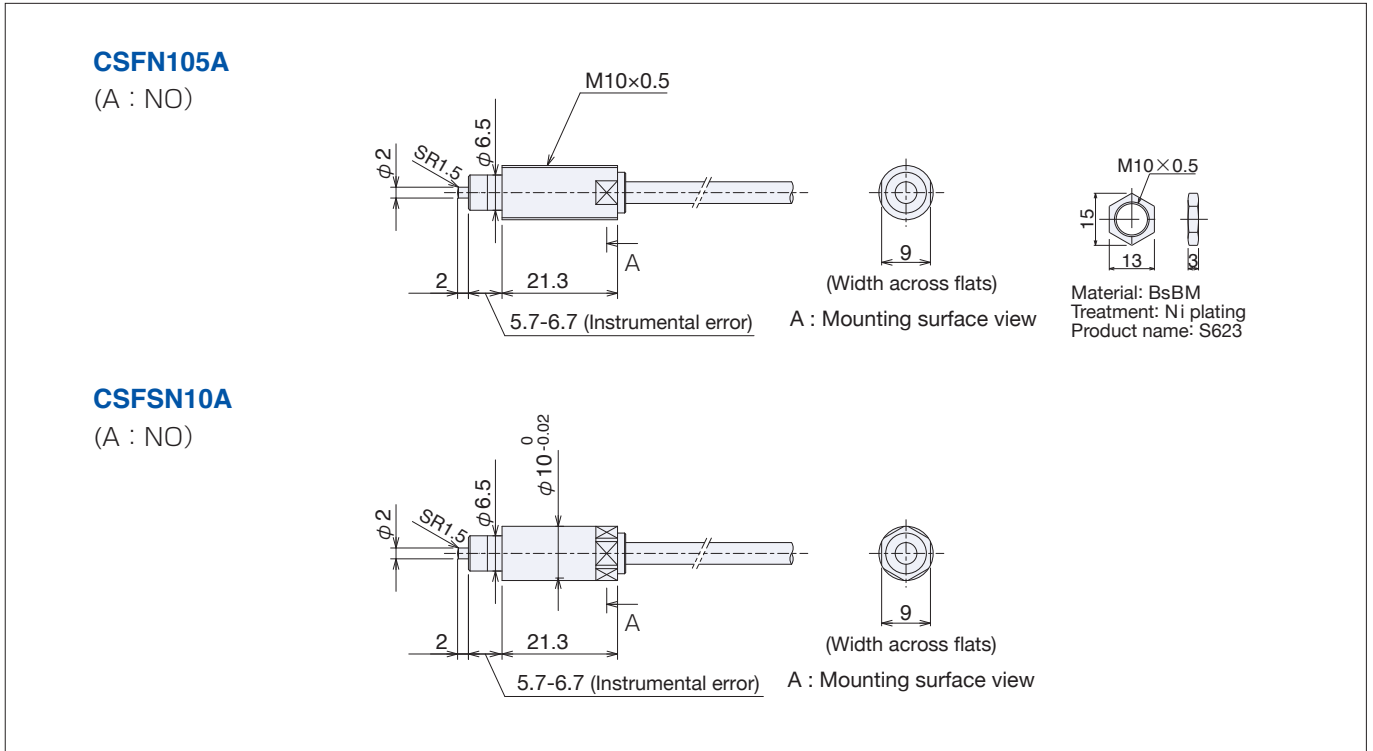

**Options**

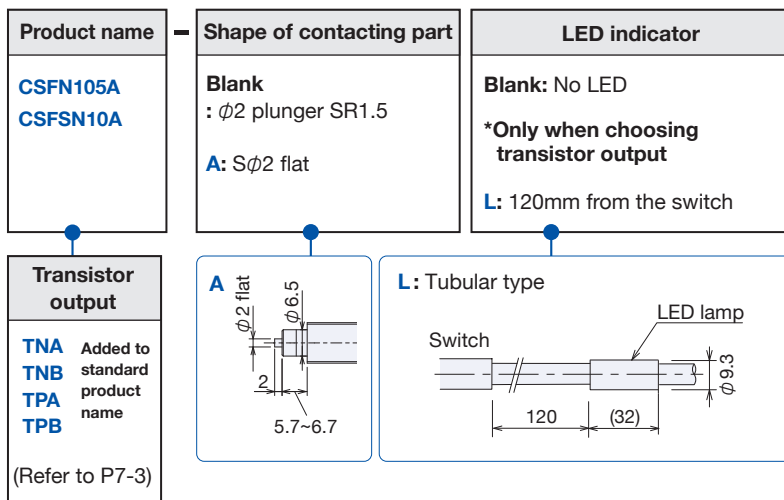

- ▶ e.g.) CSFN105A-A
- ▶ Transistor output  
 e.g.) CSFN105ATNA-AL

**Connection with program controller**

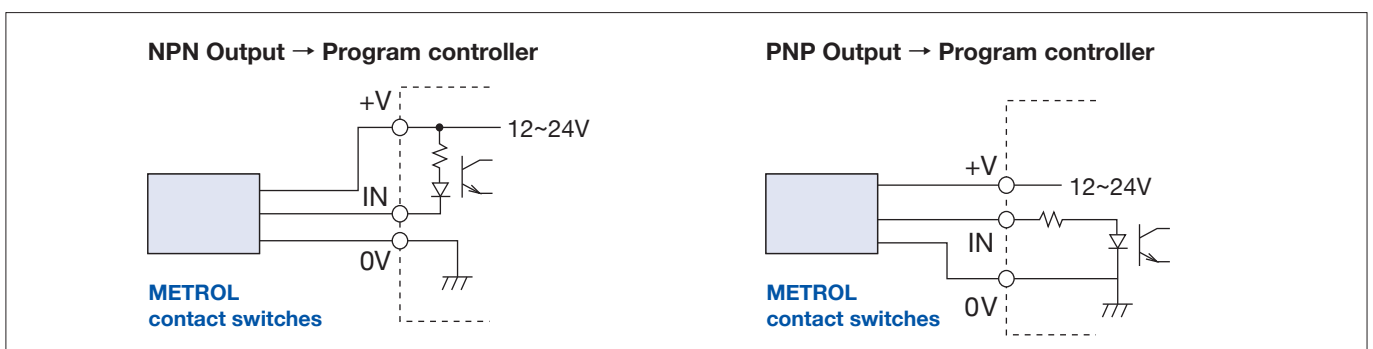

## HT series

1-signal plunger type  
**200°C Heat-resistance**



### Features

#### ■ Operating upper limit temperature 200°C

Be made of heat resistance parts / adhesives for a high temperature / heat resistance cord.

#### 《Application》

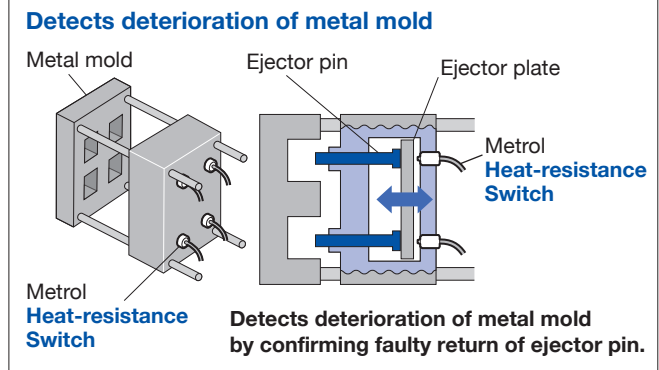

### ■ Standard specification

Series	Product name	Upper limit temperature	Stroke	Pretravel	Contact force	Withstand load	Impact resistance
CS-Touch Switch	HT-CS067A	200°C	2.8	0.3	1N	—	—
Mini Stopper Switch	HT-STM82A	200°C	0.3	Middle of the stroke	1N	3000N	0.4J
Ball Plunger Switch	HT-BP060A	200°C	0.8	0.5 from the end face	min 6N max 13N	—	—

unit : mm

### ■ Common specification

unit : mm

Switch structure	Dry contact
Output mode	A: Normally open
Repeatability	Both On→Off, Off→On/ 0.01 *1 (At operating speed 50~200mm/min) *2
Movement differential	0
Contact life time	3 million
Cable (Refer to P7-5)	Standard length 2m Heat resistant $\phi$ 2.8 / 2 cores, AWG24, Tensile strength 30N, minimum bending R28
Temperature drift	0 (because of no amplifier)
Oscillation	10-55Hz total amplitude 1.5 for X,Y,Z each direction
Impact	300m/s <sup>2</sup> for X,Y,Z each direction
Contact rating	DC5V-DC24V Steady current : 10 mA or less (rush current: 20 mA or less)
Standard accessory	Refer to Outer dimension(P6-5)

\*1 Numerical value, being used at normal temperature.

\*2 Operating speed slower than 10mm/min is not recommended.

### ■ How to use

#### Ball Plunger Switches

Suitable for angled, sliding touch.

The degree required to turn on the switch when the detected object does not meet the switch end fully.

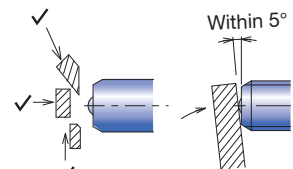

#### Other Switches

Make contact with detected objects at right angle (within deflection angle  $\pm 3^\circ$ ).

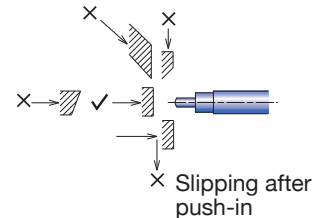

### ■ Circuit diagram

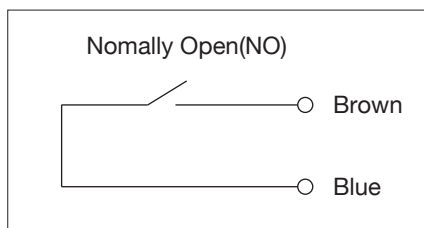

Electrical specification / circuit diagram (refer to P7-2).

## Outer dimension

### CS-Touch Switch Heat-resistance type

HT-CS067A (A: NO)

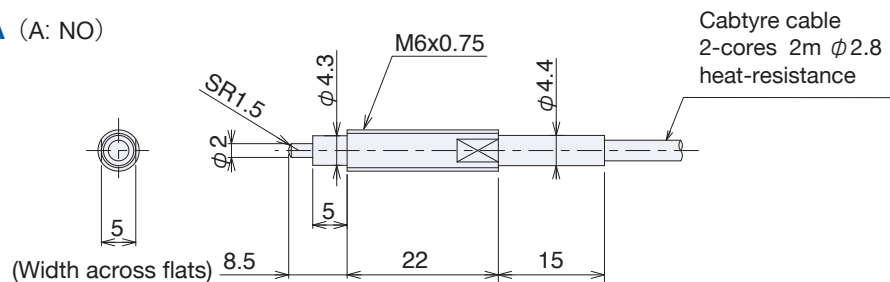

Accessories: two fixing nuts M6 x 0.75  
(Width across corners: 9.2, Width across flats: 8, Thickness: 3.2)

### Mini Stopper Switch Heat-resistance type

HT-STM82A (A : NO)

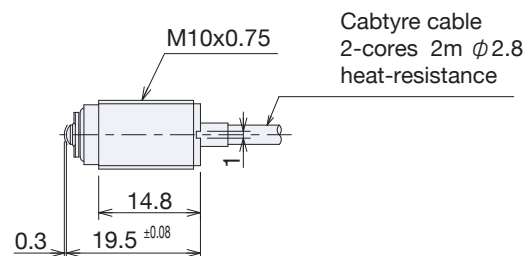

Accessories: two fixing nuts M10 x 0.75  
(Width across corners: 15, Width across flats: 13, Thickness: 3)

### Ball Plunger Switch Heat-resistance type

HT-BP060A (A: NO)

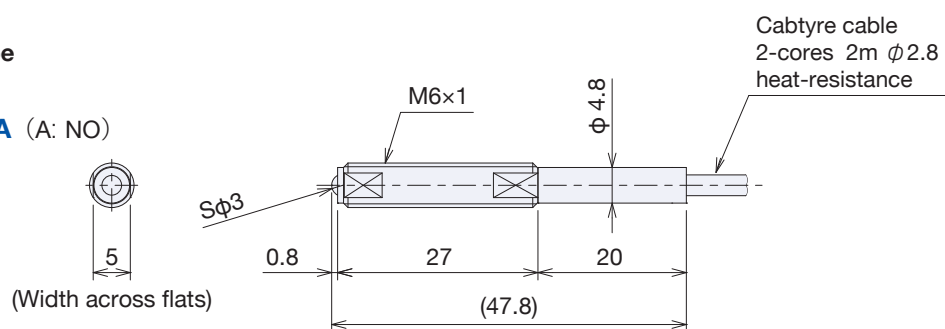

Accessories:  
· two fixing nuts M6×1  
(Width across corners:11.5, Width across flats: 10, Thickness: 3.6)  
· A toothed lock washer

## Tightening torque for case screws and nuts

	Screw / Nut	Tightening torque		
CS-Touch Switch	M6×0.75	4N·m		
Mini Stopper Switch	M10×0.75	10N·m		
Ball Plunger Switch	M6×1	L1 : 2.5N·m	L2 : 5N·m	L3 : 5N·m

### Ball Plunger Switch HT-BP060A

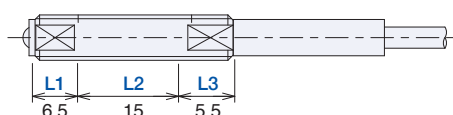

### Caution

Use the lower torque (i.e. torque corresponding to L2) while tightening the bolt between the lengths L1 and L2 in the above picture. Please make sure to use a locknut if the bolt is likely to shift in position due to the vibrational impacts.

## GN series

1 signal plunger type

**10<sup>-5</sup>Pa high-vacuum resistance**



### Features

#### 10<sup>-5</sup>Pa high-vacuum resistance switches

Adopts materials, adhesives and wiring supporting low out gas.

### 《Application》

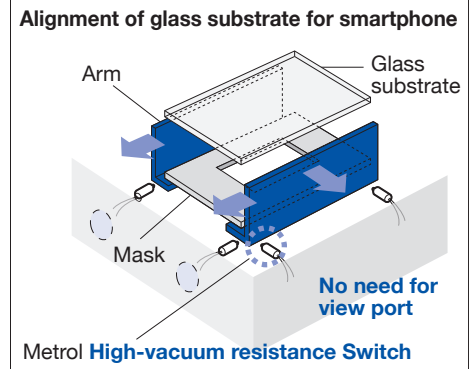

### Standard specification

Series	Product name	Output mode	Cable direction	Pretravel
PT-Touch Switch	GN-PT5M3A	A : NO	Straight	about 0.3
	GN-PT5M3B	B : NC		0 *
	GN-PT5M3A-R	A : NO	90°(R)	about 0.3
	GN-PT5M3B-R	B : NC		0 *

\* Adjust the installed location of the switch by the signal switching point.  
Operating speed slower than 10mm/min is not recommended.

### Common specification

Switch structure	Dry contact
Repeatability	Both On→Off, Off→On/ 0.003 (range) (At operating speed 50-200mm/min)
Compatible vacuum	10 <sup>-5</sup> Pa
Allowable baking temperature	120°C
Movement differential	0
Contact life time	3 million (If no specified bungle caused by vibration and used under voltage and current rating.)
Stroke	1.5
Protective structure	IP40

unit : mm

Contact material	A(NO):PEEK / B(NC):SUS HRC45
Case material	SUS304
Contact force	0.5N
Cable	PTFE Core-wire cable 0.5m AWG30
Oscillation	10 - 55Hz total amplitude 1.5 for X, Y, Z each direction
Impact	300m/s <sup>2</sup> X,Y,Z each direction
Contact rating	DC5V-DC24V Steady current : 10 mA or less (rush current: 20 mA or less)
Standard accessory	Two fixing nuts

### How to use

Make contact with detected objects at right angle (within deflection angle ±3°)

If there is a possibility to press the plunger to the stroke end, install a stopper separately to prevent the malfunction.

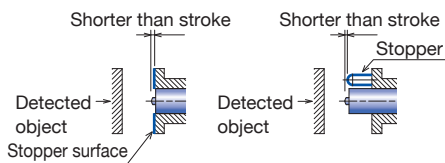
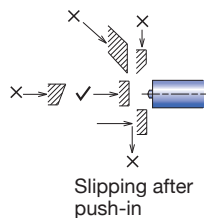

### Circuit diagram

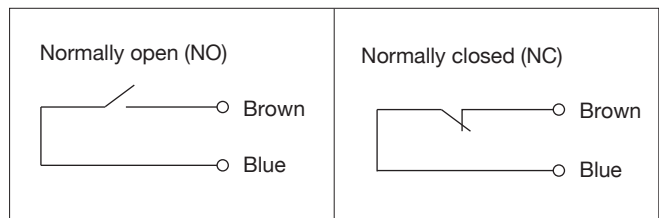

Electrical specification / circuit diagram (refer to P7-2).

### Tightening torque for case screws and nuts

	Screw / Nut	Tightning torque
Ultra-small precision PT-Touch Switch	M5×0.5	1N·m



Outer dimension

Cable direction : Straight

**GN-PT5M3A** (A : NO)

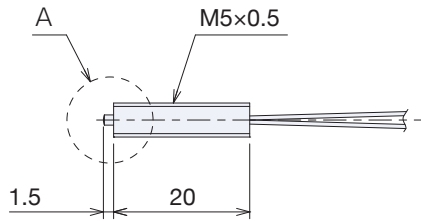

Standard accessory : Two fixing nuts M5 x 0.5  
 (Width across corners:7.7, Width across flats: 7, Thickness: 2.4)

**GN-PT5M3B** (B : NC)

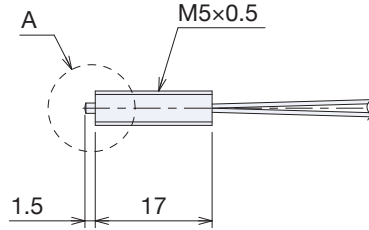

Standard accessory : Two fixing nuts M5 x 0.5  
 (Width across corners:7.7, Width across flats: 7, Thickness: 2.4)

Cable direction : 90° (-R)

**GN-PT5M3A-R** (A : NO)

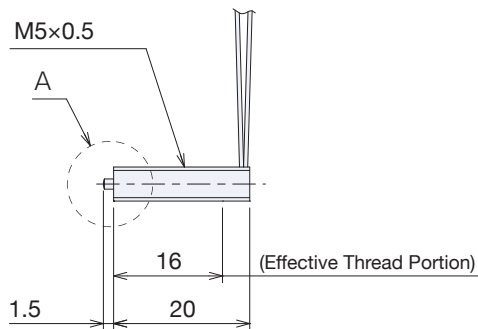

Standard accessory : Two fixing nuts M5 x 0.5  
 (Width across corners:7.7, Width across flats: 7, Thickness: 2.4)

**GN-PT5M3B-R** (B : NC)

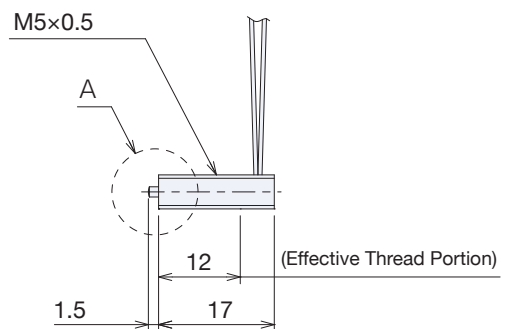

Standard accessory : Two fixing nuts M5 x 0.5  
 (Width across corners:7.7, Width across flats: 7, Thickness: 2.4)

Details of part A

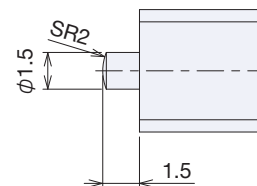

Options

Product name	Cable
GN-PT5M3A GN-PT5M3B GN-PT5M3A-R GN-PT5M3B-R	<b>Blank:</b> Standard (0.5m)  1 : 1m 3 : 3m 5 : 5m

► e.g.) GN-PT5M3A-R-3

# Common warnings and Precautions for All-purpose High-Precision Switch Series

## Electrical

- Use under the specified contact rating.
- I/F units with a built-in contact point protection circuit are effective for adverse condition environments where overcurrent may flow. Such environments may involve, regardless of the presence of contact points, inductive loads with coils (such inductive loads mainly mean relay coils, motors, solenoids, many of which require a current of 30mA or more when driven and generate counter-electromotive force when switched OFF). (Refer to P7-4)
- Since operating errors may occur due to induction when high-voltage lines or power lines are wired within the same conduit or duct as switch wires, wire them in separate ducts.
- When using the switch with LED, keep the current below 10mA.
- Chattering may occur when opening and closing the circuit with dry contacts. Take the first signal as a judgment signal.

## How to use

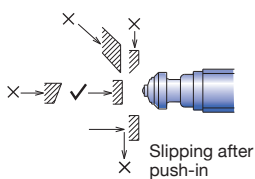

- Objects shall be aligned straight ahead for the metal bearing plunger type. (The angle must be within  $\pm 3$  degrees when high precision is required such as when using a high precision switch, or when judging existence detection or ON/OFF.)

- For the metal bearing, pressing while offset (deviated from the axis) will cause the movement of the axis to be unsmooth and wear fast.

- For slide, deflection angle, or offset contacts, select bearing or ball contact or lever type.
- When the plunger is pushed straight by the detected object, do not allow the object to abruptly slide away, as it will cause the plunger to snap back. Note that this may cause failure of the bearing and built-in switching part.
- Please also note that forcing the plunger in by your fingers and letting go (snapping it back out) may also cause failure of the internal contact point.
- In case the detected surface is angled or ragged, note that the switch may fail to operate properly or cause malfunction.
- If the contacting part is worn away depending on conditions, the signal point becomes different. When designing the detected objects, give consideration to its angle, chamfer and roughness so that the contacting part holds up longer. (Mainly for sliding touch type)
- Normally-close (NC) type structure might cause chattering depending on the roughness of workpiece surface and environment used (i.e. vibration and contacting speed). In such case, please select Normally-open (NO) type switch.
- Use it with the operating speed of 50 to 200 mm/min when precision is required.

### For the switches without stopper

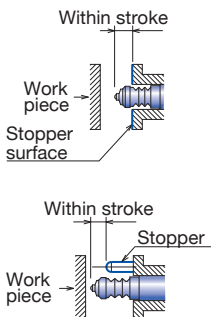

- Do not excessively press the plunger to the stroke end. It may cause malfunction due to impact.
- If there is possibility to press the plunger to the stroke end, install a separate stopper to prevent malfunction.

## Operating environment

- Use in the environment in where cuttings and dust don't prevent switch movement.
- Choose protective cover option in case cutting may damage the rubber boot. Further, choose a suitable cover such that coolant and cutting chips do not enter from the cover gap.
- An extra cover is recommended to avoid direct hit by high-pressure coolant or heavy cuttings.
- Periodically remove chips and dust. Apply force to the movable parts only in the direction of measurement. Do not apply force in the other direction.

## Contacting part material

- Even though hardened stainless steel is used as the material of the contacting part or stopper surface, they are oxidized and may gather rust under certain conditions.

## Rubber for protective structure (boot, seal, O-ring)

- Rubbers for some products are intended for water-soluble cutting oil (alkaline). For oily, chlorine-base, coolants and other chemicals, consult METROL for assistance.
- The rubber material for High-precision MT-Touch Switch is for both oily and water-soluble coolants.
- Rubber might be hardened when the ambient temperature is low. When the contact is depressed for a long period of time, it might take longer time for the contact to return the original position.

## Installation

- Ensure that the threaded part of the switch is not bent during installation. When tilted, it may result in poor signal.
- When using fixing screws, do not tighten the screws with excessive force. That may distort the switch shape or restrict the movement of the plunger. If the fixing screws are damaged, the switch can be stuck and difficult to be detached.
- When the switch with a protective cover is installed horizontally, an extra cover is needed separately to prevent coolant or cuttings from entering inside and getting piled up on the switch.
- Do not subject cable or core wire cable to excessive pulling or twisting of 30N or more. The bending radius should be at least R7. (except for heat resistance cable)
- Do not swing the switch by grabbing the wires or its attaching portion when installing (especially when the wire is perpendicular to the switch).
- When installing it with several cables, hold the switch to avoid the cables from being pulled by weight.

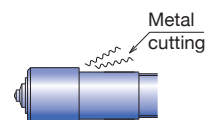

## Contact type with dry contacts for switching part

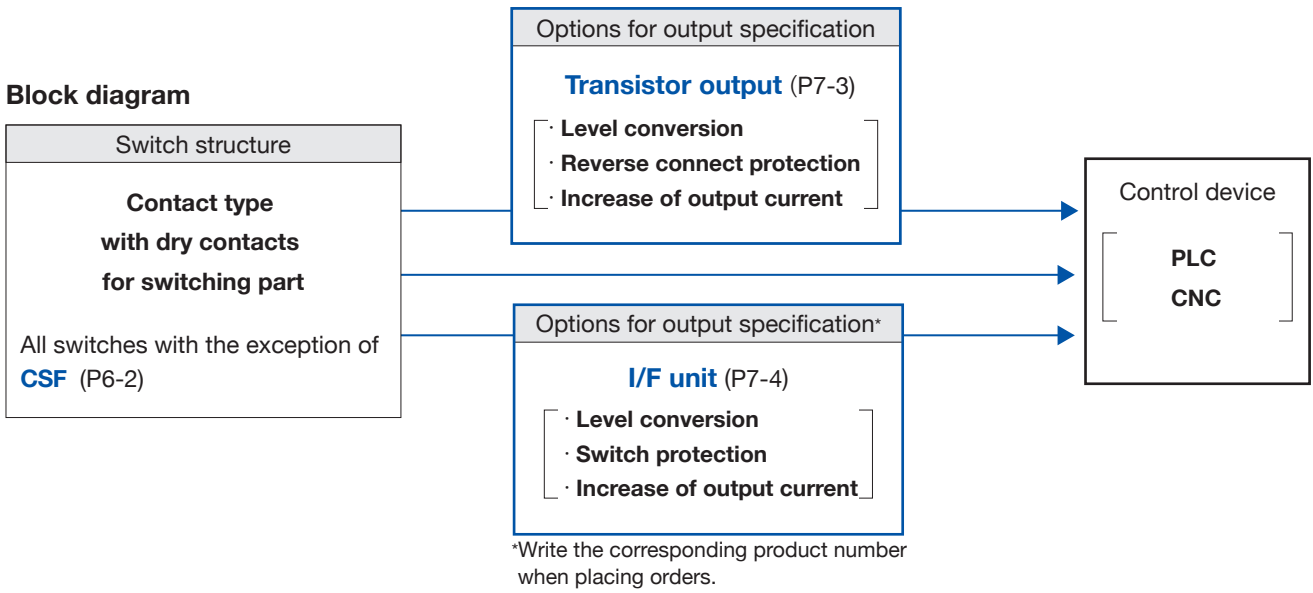

### Specification

Contact rating	DC5V-DC24V Steady current: 10 mA or less Rush current : 20 mA or less (Switch without LED, DC1V-24V possible)
Insulation resistance	More than 100MΩ with DC250V Megger
Output mode	A : Normally open or B : Normally close

### Precautions for connection

Current control to limit the current to less than 20 mA is required when I/F unit is not used.

Refer to P14-3 about how to use switches under the condition of AC100V-200V.

### Circuit diagram

High-precision MT-Touch Switch 1-signal type

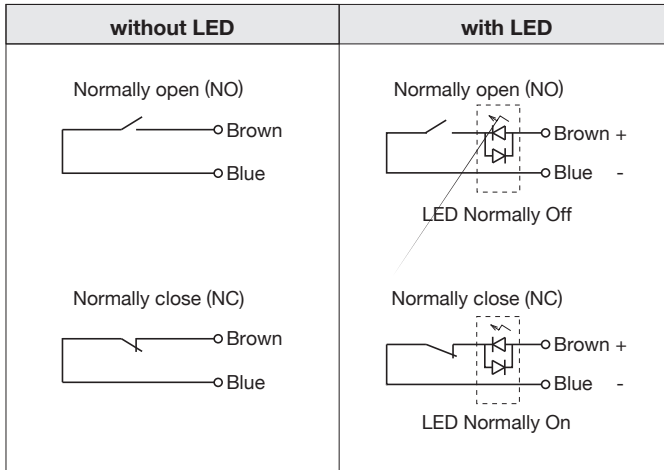

CS-Touch Switch and others

(Other than High-precision MT-Touch Switch 1-signal types)

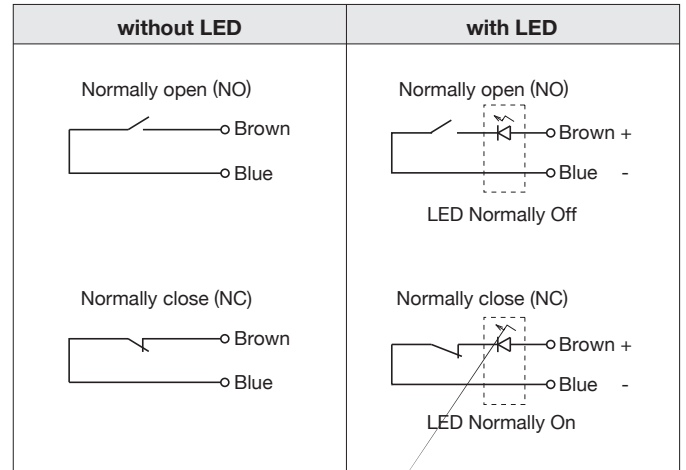

When using the switches with LED option, limit the current below 10mA. (Refer to P14-3 "Confirmation of switch operation".)

## How to replace currently using proximity switches (3-core and 2-core type) with METROL (2-core type)

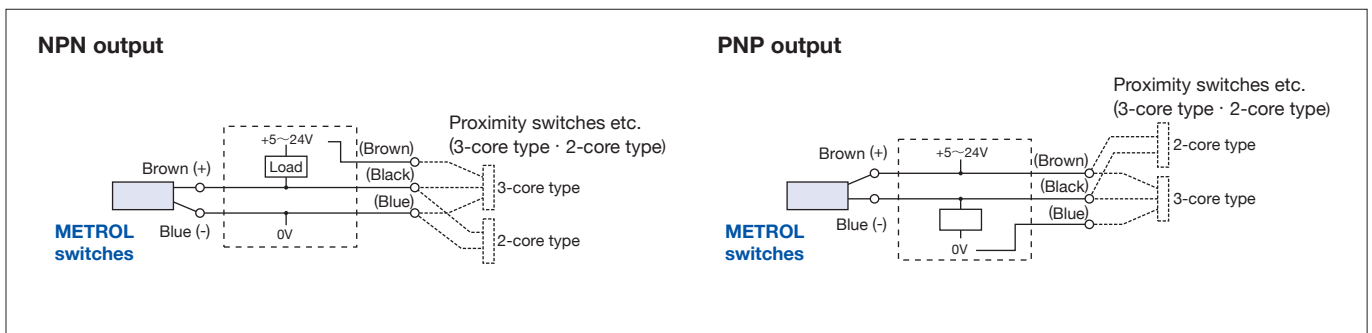

## Transistor output



### Option type for transistor output

Option types for transistor output	Output mode
Add to standard product name	<b>TNA</b> NPN-NO
	<b>TNB</b> NPN-NC
	<b>TPA</b> PNP-NO
	<b>TPB</b> PNP-NC

e.g. P085DBTNA

### Specification

Power supply voltage	DC12V-DC24V
Current consumption	Less than 10mA
Output current	100mA Resistance load
Output mode	A:Normally open or B:Normally close
Output specification	NPN open collector or PNP open collector
Remaning voltage	Less than 1V (50mA)
Leakage current	Less than 0.8mA
Insulation resistance	More than 100MΩ with DC250V Megger
Protection circuit	Protection circuit in case of reverse connection

### Character

- 1) Increase the output current to 100mA (Resistant load)**  
Enable to drive a relay (MAX 100mA) or similar devices directly.\*
- 2) Protection circuit in case of reverse connection**  
No break down even when the switch is connected wrongly (between + and - terminals).
- 3) Level conversion unit**  
Level conversion (normally close to normally open, normally open to normally close)

\* When driving a relay by this unit, the repetitive accuracy would be lowered due to delay of the relay.

### Outer dimension

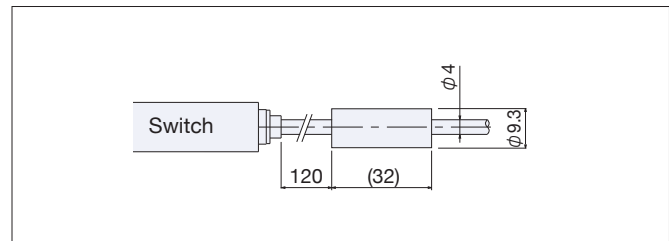

### Circuit diagram

NPN opencollector

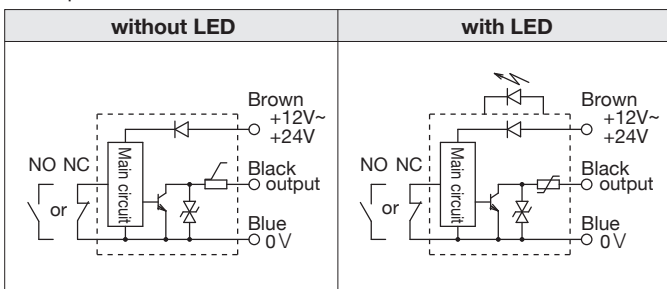

PNP opencollector

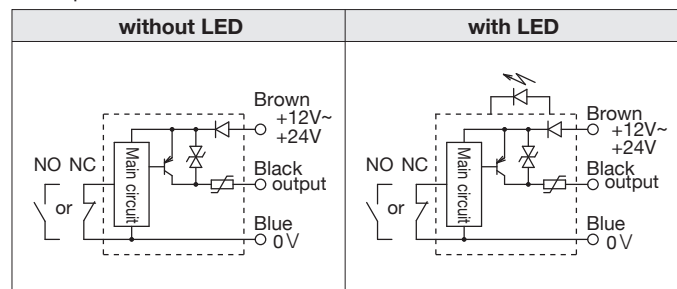

### Precautions for switch connection

Always make sure to turn off the power before installing or removing switches. This is to prevent damage to the device caused by improper wiring or short-circuits of output lines.

Photo MOS Output Type

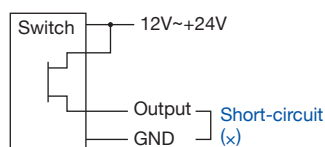

NPN Transistor Output Type

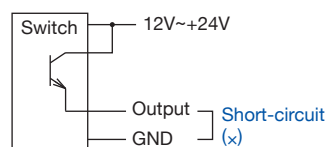

### Improper Connections

NPN Output Switches

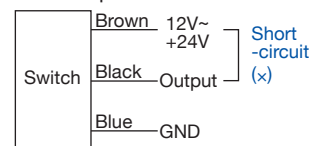

PNP Output Switches

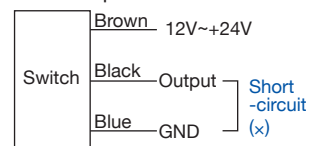

NPN Output Switches

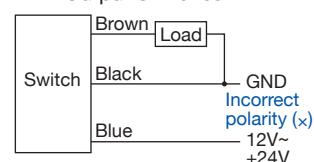

PNP Output Switches

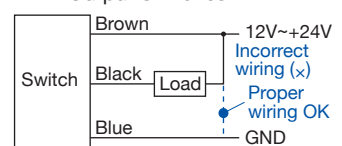

# Electrical specification Options for output specification

## I/F unit for contact type switch



### Specification

Product name	CL-1F	
Power supply voltage	DC24V ±10% (ripple 5% or less)	
Power consumption	15mA	
Input	One contact signal	
Output method	Photo Mos relay	
Diagram		
Output level	No-voltage floating output	
Output capacity	AC/DC200V (Max) 100mA(Max)	
Operating time	Delay	500μs (Representing value)
	Spread	10-20μs
Operating temperature range	0°C-50°C	

### Character

- 1) Protection for the dry contacts from inrush current**  
The interface unit is not needed, when using the switches under the contact rating.  
The contact point is unaffected by load current and protected since the I/O circuits for the contact current of the touch switch are separated.
- 2) Increase the output current**  
Enable to drive a relay or similar devices directly.  
When driving a relay by this unit, the repetitive accuracy would be lowered due to delay of the relay.
- 3) Level conversion unit**  
Level conversion (normally close to normally open, normally open to normally close)

### Precautions for use I/F unit

- Do not connect the load exceeding the output rating specified for each model.  
Since the switching parts and interface elements may be damaged due to the flow of current in excess of the rating caused by noise or surge induction, place the switch at an adequate distance from any power lines or other sources of noise.
- Connect one switch to one I/F unit.
- Select the installation location of I/F unit so that the cable length between the switch and the I/F unit should not exceed 20m .
- Since the I/F unit is not waterproof, protect it from moisture such as water and oil.
- In case of using Normally-open type switch with a LED indicator, I/F unit can be used only when the LED is normally OFF and turns ON in operation.  
Similarly, for Normally-Close type switch, the unit can be used only when the LED is normally ON and turns OFF in operation.
- This I/F unit is especially designed for the METROL switches, do not use this I/F unit with the switch from other manufacturers.

### Connecting diagram with electrical load

#### Photo MOS output type

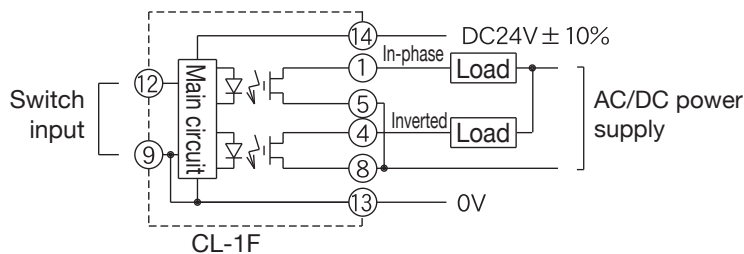

#### In case used equivalent to NPN open collector output form

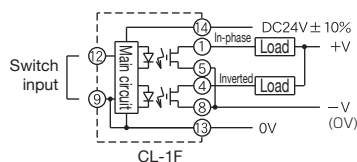

#### In case used equivalent to PNP open collector output form

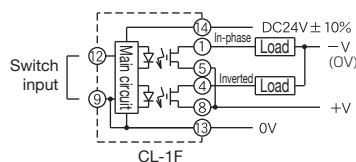

### Outer dimension

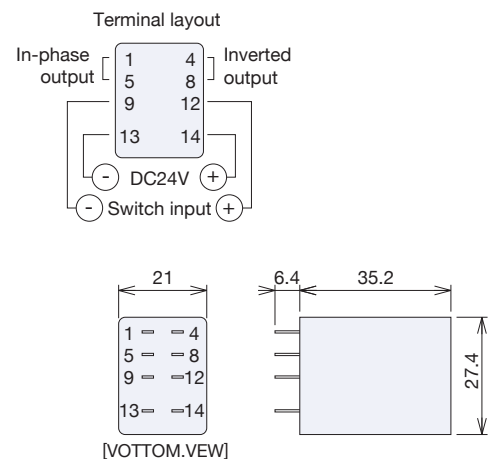

No terminal block is provided.

Refer to the following.

Panasonic: HC2-SFD-S

Omron: PYF-08A

#### Connection diagram (Plural switches)

When connecting plural switches to one plug-in type interface unit, refer to the diagram below.

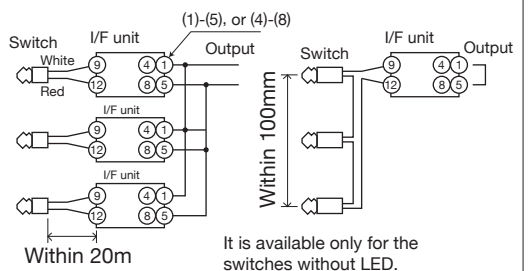

- Make sure no noise and inductive source.
- Overall length of the sensor side cables should not exceed 100mm.

# Cable related option entry

## Cable option format

The following cable related options are available.

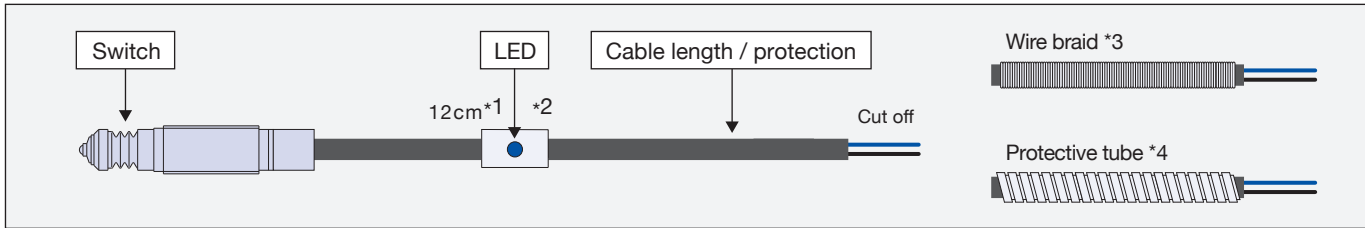

\*1 Cord protection cannot be fitted to the 12cm section. \*3 Refer to following.  
 \*2 Cord protection cannot be fixed on the LED side. \*4 Applicable to cables of  $\phi 5$  or larger. Refer to following

## Type of cable

### Cabtyre cable

Cabtyre cables are used as robot cables without any safety compromise since the working voltage and current are low, though cabtyre cables are not applicable to UL, CSA, EN or other safety standards.

### Specification

Conductor material	Copper-tin alloy, tight winding
Conductor resistance	1 $\Omega$ /m (per 1 core)
Sheath material	PVC (Non-migrating styrene, oil-resistant, alkaline-resistant)
Minimum bending radius	7mm
Outer diameter	$\phi 2.8$ (2-core) $\phi 4$ (2-core, 3-core) $\phi 5$ (2-core, 4-core) $\phi 5.5$ (16-core)
Sheath color	<b>Black</b> : 2-cores, 4-cores for Normally close 3-cores are for transistor output, CSF. <b>Gray</b> : 2-cores for Normally open (Excludes High-precision MT-Touch Switch series)

### Cross-section area / weight (Including sheath / 1m)

Outer diameter	Cores	AWG	Cross-section area (mm <sup>2</sup> )	Weight (g)
$\phi 2.8$	2-core	AWG 26	(0.151mm <sup>2</sup> )	10g
$\phi 4$	2-core	AWG 30	(0.063mm <sup>2</sup> )	16g
$\phi 4$	3-core	AWG 30	(0.063mm <sup>2</sup> )	18g
$\phi 5$	2-core	AWG 30	(0.063mm <sup>2</sup> )	26g
$\phi 5$	4-core	AWG 30	(0.063mm <sup>2</sup> )	32g
$\phi 5.5$	16-core	AWG 28	(0.08mm <sup>2</sup> )	40g

## Cable protection (Protective structure, Refer to P14-5)

### Wire braid for protection

Material : Steel wire, Clockwise Tight winding  
 Minimum bending radius : 7mm  
 Mark : **W**

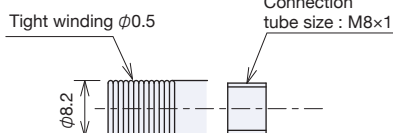

### Precautions

- 1) Switch side is fastened with screws and machine side is simply cut. When extension is needed, use threaded connection tube.
- 2) Since gaps are formed at bend section (especially at the attachment end) of the wire braid, make sure the instruction of cuttings does not damage the cable.
- 3) Be careful not to damage the cable sheath as a result of crushing it during clamping.
- 4) When binding it up and clamp with other cables, make sure not to apply excessive force to the attachment end.
- 5) Wire braids extend by their own weight. Fabricate wire braids slightly shorter than the cable length.

### Precautions

- 1) Do not pull or twist the cable with excessive force. Max.30N (3kgf)
- 2) Precautions for protective structure (refer to P14-5)
- 3) When extending cable length, use cabtyre cable having a cross-section area of at least 0.2mm<sup>2</sup>.
- 4) The minimum bending radius is R7. (except for heat resistance cable)
- 5) The cable protector is detachable.

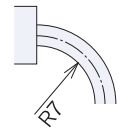

Disassembly Drawing

Example : STS060PA

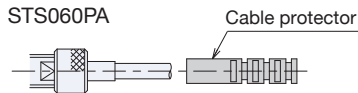

## Core-wire cable

- Ultra-small precision PT-Touch Switch core-wire type (P3-4)
- CS-Touch Switch CSM core-wire type (P4-13)
- Mini Stopper Switch STM short type (P5-10)

### Specification

Outer diameter	$\phi 0.6$ single core
Cross-section area	AWG 30 (0.05mm <sup>2</sup> )
Tensile strength	15N

## Protective tube

Used mainly in machining environment (Protection for cuttings).  
 (Not applicable to the cable having diameter smaller than  $\phi 5$ )

Dimension: outer diameter  $\phi 9$   
 Minimum bending radius : 25mm  
 Mark : **P**

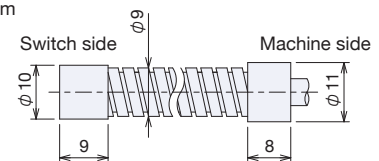

### Precautions

- 1) Switch side is screwed in and metal ring is attached to machine side.
- 2) Because protective tube is not flexible, clamp it to fix so as not apply excessive force to the switch.
- 3) When binding it up and clamping with other cables, make sure not to apply excessive force to the attachment end.
- 4) Cables are not waterproof.

# Options Contacting parts

## Detachable contacting parts (sold separately)

### Fixed contacting parts

Outer dimension	Product name	Outer dimension	Product name	Outer dimension	Product name
	<b>F4130W</b> Tungsten carbide		<b>F4150W</b> Tungsten carbide		<b>F4129W</b> Tungsten carbide
	<b>F4131W</b> Tungsten carbide		<b>F4132W</b> Tungsten carbide		<b>F4161W</b> Tungsten carbide

Accessory for the fixed contacting parts : Spanner

This can make installation process easier and eliminate the risk of twisting the cable when adjusting the signal point of the switch.

Outer dimension	Product name	Outer dimension	Product name	Outer dimension	Product name
	<b>F4130AW</b> Tungsten carbide		<b>F4150AW</b> Tungsten carbide		<b>F4129AW</b> Tungsten carbide
	<b>F4131AW</b> Tungsten carbide		<b>F4132AW</b> Tungsten carbide		<b>F4161AW</b> Tungsten carbide

Accessory for the adjustable contacting parts : Locknut for adjustment and spanner

### How to set the signal point with adjustable contacts

Fine adjustment by the contact screw (about  $\pm 0.5$ )

The switch is locked in position with the nut.

- Able to prevent loosening
- Particularly convenient for making internal corrections.

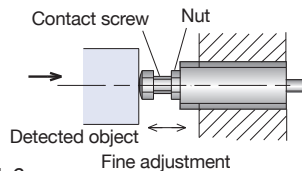

Extracted from Technical Guide P14-6

### Applicable models for fixed/adjustable contacting parts

#### High-precision MT-Touch Switch

P10 / P12 (P3-10)

P10DH (P3-16)



# CNC MACHINE TOOLS SERIES

■ Touch Probe Series for CNC Machine Tools



■ Tool Setter Series for CNC Machining Centers



■ Tool Setter Series for CNC Lathes

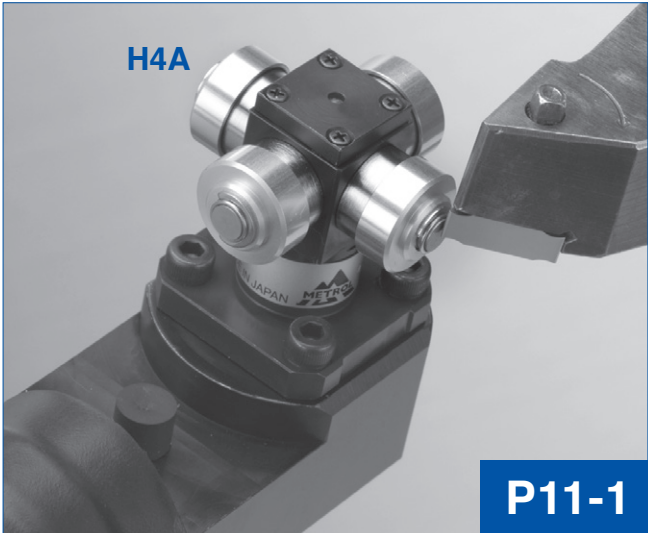

■ Drill Bit Breakage Detection Sensor

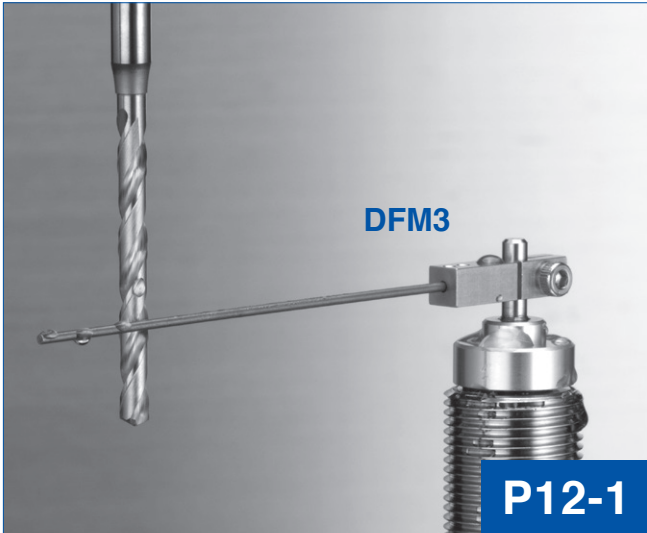

## Touch Probe Series for CNC Machine Tools

### With Wire

#### ■ 1 $\mu$ m Repeatability

· 3-Dimension	<b>K3E</b> .....	P9-5
-----	<b>K3M</b> .....	P9-7
· $\pm$ X / Z3-Direction(With pretravel)	<b>K2A</b> .....	P9-9
-----	<b>K2C</b> .....	P9-11
· $\pm$ X / Z3-Direction(Without pretravel)	<b>E2A</b> .....	P9-13
-----		
· $\pm$ X 2-Direction		
-----		

## Tool Setter Series for CNC Machining Centers

#### ■ 1 $\mu$ m Repeatability

· For Vertical Machining Centers $\Phi$ 20Contact	<b>TM26D</b> .....	P10-5
-----	<b>T24E-120</b> .....	P10-8
-----	<b>T20-120</b> .....	P10-11
-----	<b>T24E-240</b> .....	P10-9
-----	<b>T24E-260</b> .....	P10-10
· For Horizontal Machining Centers	<b>T26K</b> .....	P10-13
-----	<b>P21</b> .....	P10-15
· For Small Machining Centers	<b>TD1</b> .....	P10-17
-----		
· For Length and Diameter Measurement		
-----		

## Tool Setter Series for CNC Lathes

#### ■ 1 $\mu$ m Repeatability

· Linear Type	<b>H4A</b> .....	P11-3
-----	<b>H4E</b> .....	P11-5
· Swing Contact Type		
-----		

## Drill Bit Breakage Detection Sensor

#### ■ Pneumatic Drive Type

**DFM3** .....

P12-1

## Selection by application

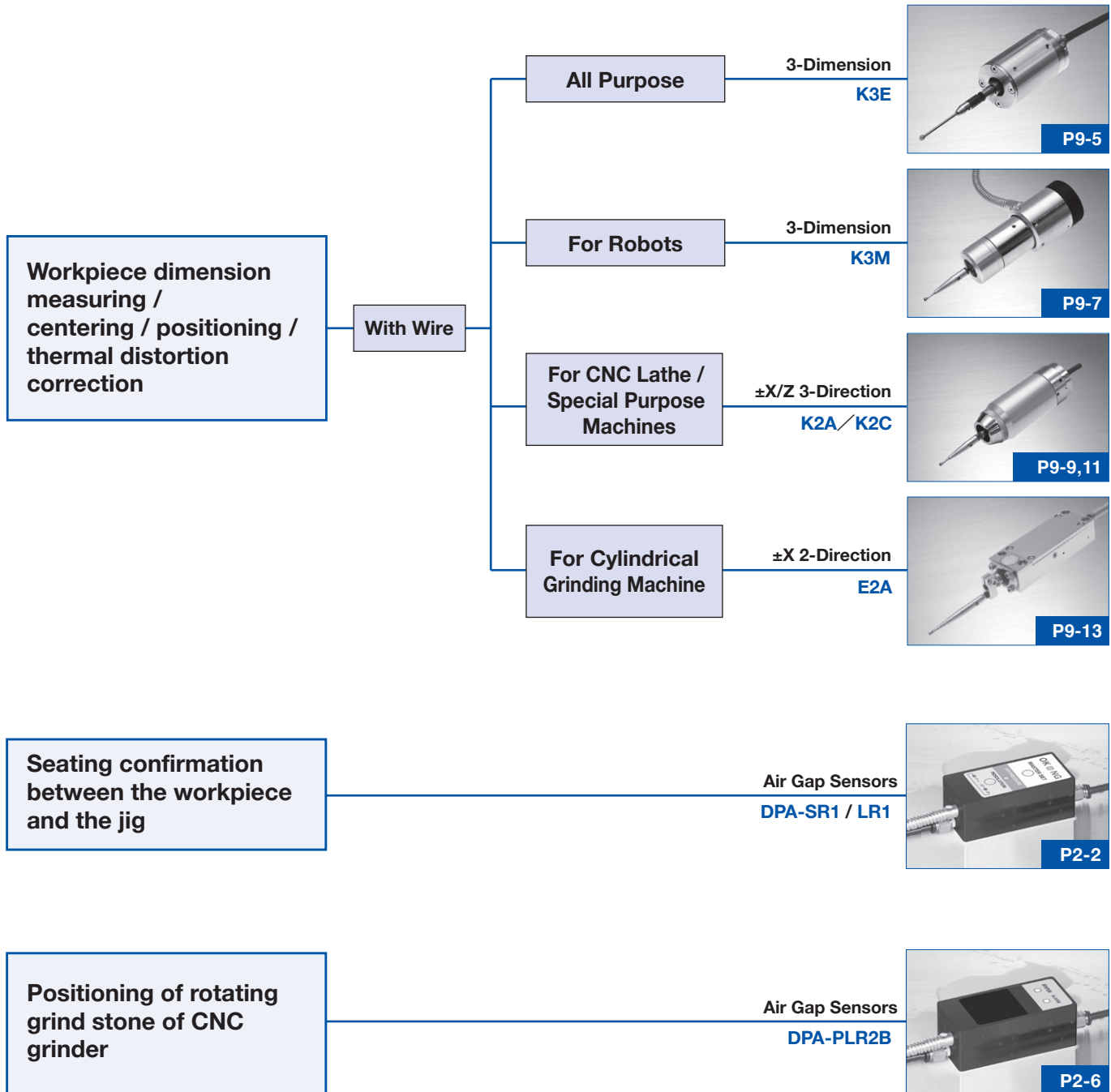

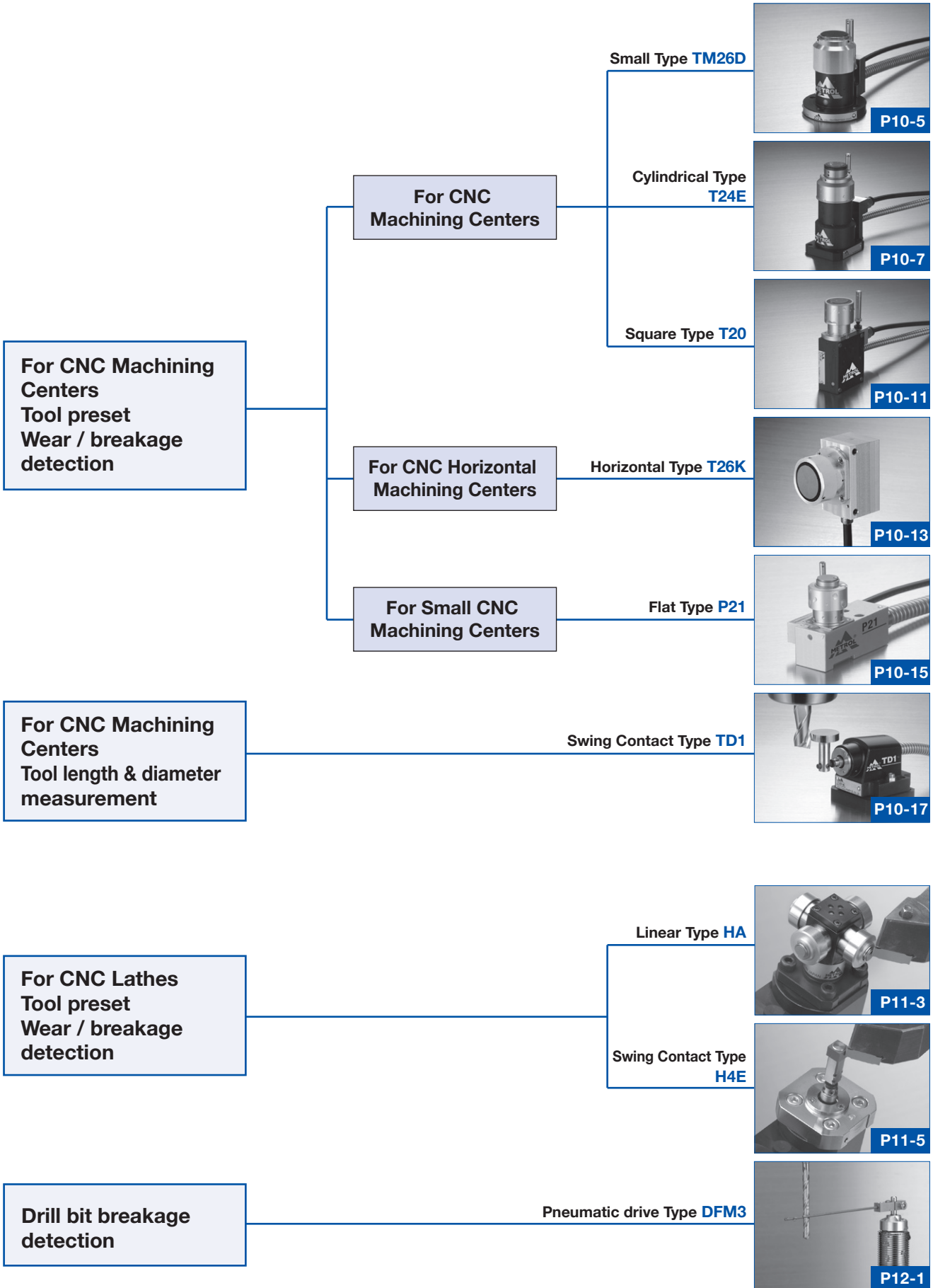

# Touch Probe Series for CNC Machine Tools

## Summary

- Touch probes can be used for measuring workpiece dimensions, centering or positioning by installing in CNC machines such as lathes, machining centers, grinders, special-purpose machines or robots.
- When the stylus makes contact with a workpiece or table, a high-precision ON/OFF output signal is generated and that is sent to the CNC or PC device.
- An I/F unit for protecting the contact can be provided internally or installed externally.

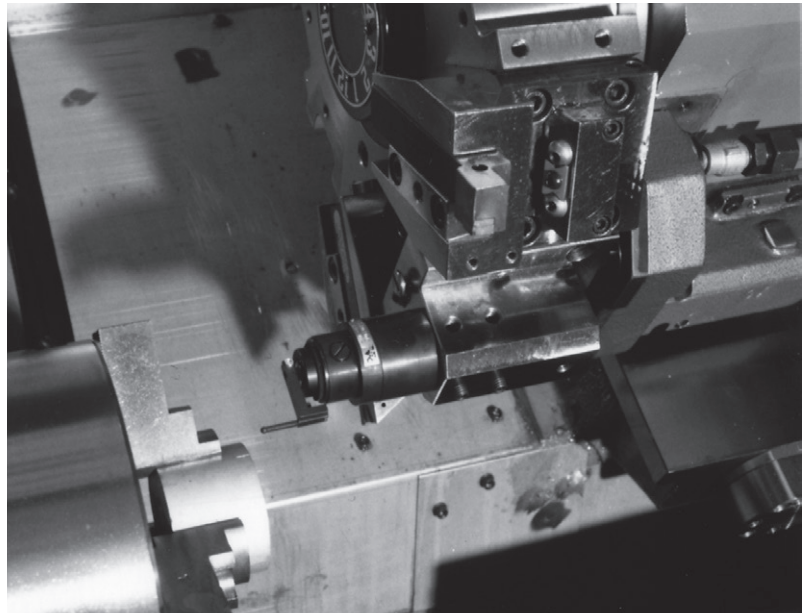

## Features

- 1) The internal switch is of the contact type, has high precision, and is free of movement differential.
- 2) Since there is no need of an amplifier, there is no temperature drift caused by self-generation and temperature characteristic of the sensor unit.
- 3) Outputs over-travel warning signal (Only E2A).

	With pretravel	Without pretravel
Structure	High-precision, high-durable internal touch switch able to be operated by movement of the stylus.	As the built-in contact serves as a swing fulcrum, the ON → OFF signal is output instantaneously as the fulcrum moves away.
Drawings for basic structure		
Features	<ul style="list-style-type: none"> <li>· The finger needs to be pushed in from the position in which the contact ball is in contact with the workpiece until it starts operating. (for relative position detection)</li> <li>· Resistant to occurrence of erroneous signals and chattering caused by vibrations and impacts.</li> <li>· Material having low electrical resistance used for contact switch for extremely long contact life.</li> </ul>	<ul style="list-style-type: none"> <li>· As it starts operating at the moment it touches, high-precision position detection is possible.</li> <li>· Susceptible to occurrence of erroneous signals and chattering caused by vibrations and impacts.</li> <li>· Inferior contact life since contact switch are required to be hard and there are restriction on contact materials.</li> </ul>

## Selection Guide

- A wide variety of dedicated types depending on the intended use.

### Application

Measuring workpiece dimensions, Centering, Positioning, Correcting thermal distortion

With Wire

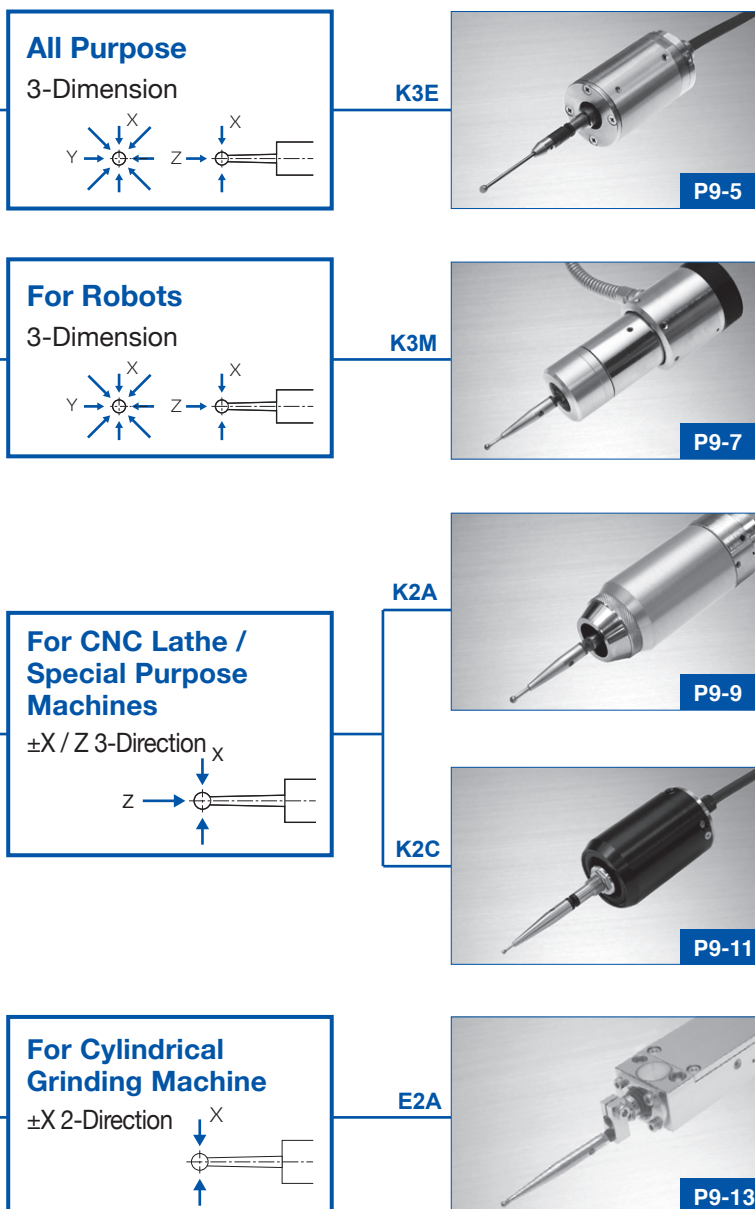

### Touch probes with wire

(mm)

Product name	K3E	K2A	K2C	K3M	E2A
Direction	3-Dimension 	±X / Z 3-Dimension 	±X / Z 3-Dimension 	3-Dimension 	±X 2-Direction 
Pretravel	Without pretravel	With pretravel	Without pretravel	With pretravel	With pretravel
Application	Measuring outer diameter, inner diameter, end surfaces and centering			For robots	Measuring end surfaces for grinder
I/F unit (P13-5)	External	Built-in/External	External	Built-in	External
Page	P9-5	P9-9	P9-11	P9-7	P9-13



# Touch Probe (with wire) Selection Parameters and Precaution

## Stylus

1. The Stylus length can be optionally selected. The material may be changed depending on the length. (shaft standard: stainless steel)
2. Tungsten carbide balls with a diameter of  $S\phi 2-\phi 5$  are used for the contact.(except for K3E)
3. Accuracy and movement before operation vary according to stylus length, mounting orientation and amount of offset.
4. Use the shortest stylus as possible. Long stylus is more likely to cause chattering and malfunctions due to vibrations or impacts.
5. The stylus should be firmly fixed to the sensor head.
6. Remove adhesion of coolant or cutting chips onto the stylus in order to prevent variations in signal point.
7. Replace the stylus when it is worn or stuck with foreign substances which cannot be cleaned up.
8. The larger ball contact reduces the effect of the surface finish of the workpiece being inspected, avoiding erroneous measurement.

## Shear screw

1. Once a horizontal overload is applied to the stylus, the shear screw breaks to protect the interior.
2. Replace the shear screw by referring to the instruction manual. Replacement by a wrong procedure may result in damaging the interior.

## Contact structure (Output mode)

Output mode (Contact structure)

<b>NC (b contact)</b>	The contact is normally closed (ON) and opened during operation (OFF). Available with and without pretravel. Malfunctions(disconnection / contact troubles) diagnosed using interlock (fail-safe).
<b>NO (a contact)</b>	Contact normally open (OFF). Closed during measurement (ON). All NO types have pretravel.

### Circuit diagram

Nomally closed (NC)

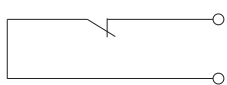

Nomally open (NO)

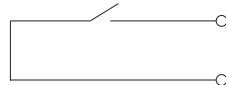

## Mounting

- The shape of the mounting portion depends on the model. Please refer to each product page.
- Directional pins are used for  $\pm X$ , Z 3-Direction type (K2A, K2C)

## Cables

1. Do not pull on cables with excessive force (up to about 30N (3 kgf)).
2. The cable bending radius should be R7 or more.
3. Since switch contacts may be damaged by the current higher than the rated due to induction of noise and surges, install cables as far away from motor power sources and noise sources as possible (particularly when bundling cables).
4. Do not damage cables during wiring. This impairs water resistance capacity.
5. Cover cables with protective tubes when there is a risk of damaging to cables by the usage environment. Minimum bending radius when using protective tubes is R25.

## Electrical

1. Contact rating: DC5V - DC24V  
Steady current :10mA or less (Rush current : 20mA or less)
2. Make electrical connections so that the sensor is grounded when the machine body is grounded.
3. As the sensors with LED have polarity, please be aware of the (+) (-) connection. Recommended value of 10 mA, resistive load. Limit the LED forward current below 10mA.
4. In the case of using I/F unit, refer to P13-5 for output specification.

## Connectors (refer to P13-4)

Cables can be branched between the sensor and machine with connectors, thereby facilitating assembly and maintenance. these connectors are waterproof, and highly durable.

### Connectors

The connector is attached at a midpoint in the cable (distance from sensor : 1m)

**Note:** Do not pull the cable when remove the connector. Press the connector firmly until it tightly fits with O-ring.



## ■ Protective covers

Protective covers are for preventing damage to rubber boots and impairment of water-resistance or dustproofing caused by metal fragments and other cutting.

- 1) Protective covers are not provided for some products.  
In that case, an extra cover is needed to protect rubber boot from damaging by cutting chips.
- 2) Even for products with boots protective covers, please consider the mounting orientation, direction of the chips and coolant and the like to make sure that chips and coolant do not get accumulated within the boots protection cover.

## ■ Proper Tool Contact

- 1) Ensure that the workpiece touches the contact along a straight line in the direction in which it is pushed.
- 2) Do not excessively press the stylus to the stroke end.  
It may damage the sensor or the workpiece.
- 3) Set to a lower speed in the case of measuring workpieces made of flexible materials such as aluminum or resin. However, operating speed slower than 10mm/min is not recommended.
- 4) Even for the same work, changing the operation speed will cause errors in accuracy.

**Note :** Please be sure that the operating speed when the contact that has been pushed in is returned to the original state is within the range in which the contact can follow the work. When it is rapidly returned, the internal may be damaged in reaction.  
Similarly, do not return it rapidly when testing it with a finger during installation, cleaning, etc.

### ● Requesting Quotation

- Send us the quotation request along with attached spec sheet (with additional requirement if any) by Fax/E-mail.

FAX: +81 42 528 1442/

Email: touchsensor@metrol.co.jp

- The format (figure number) is determined when the delivery specification figure is submitted.

### ● Ordering Replacement and Spare Parts

- Please specify the product name (model name) on the nameplate attached to the product.
- Please add an "H" after the product No. when not requiring accessories such as an I/F unit or relay cable (machine side). Please add an "S" when ordering a set.

# K3E

## 3-Dimension (all-round) Type



■ Touch probes for CNC Machine Tools are used for measuring of workpiece dimensions, centering and positioning.

### Standard specifications

(mm)

Product name	<b>K3E</b>
Contact structure	NC (Normally closed)
Output mode	NO (Normally open)
Pretravel	0
Stroke*	X,Y=±7° Z=3
Repeatability	0.001 (2σ) (Recommended operating speed of 50 - 200mm/min)
Contact life time	3million
Protective structure	IP67
Contact force*	X,Y=0.5N Z=5.5N
Contact material	Tungsten carbide ball
Cable	Oil resistant φ5 / 4 cores Tensile strength 30N, Minimum bending R7
Operating temperature range	0°C-60°C (Ice-free)

\* with stylus (F-R40T-405)

### Circuit diagram

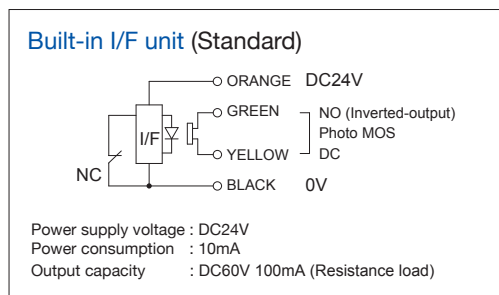

### Precautions

- As the built-in contact serves as a swing fulcrum, excessive operation speed will accelerate the deterioration of the contacts. In addition, as the contact material with low electrical resistance cannot be used, it needs to be energized only during measurement to protect the contact life.
- Operating speed slower than 10mm/min is not recommended.

- Precautions for Touch Probe...P9-7
- Precautions for Sensor Connecting...P13-2
- Technical Guide...P14-1
- Cable Options...P13-4

### Stylus list

(mm)

Product No.	Material		D	φd	L1	L2
	Ball	Shaft				
F-R60C-405	Ruby	Ceramic	6.0	3	40.5	33
F-R50T-405		Tungsten carbide	5.0	2.5	40.5	33
F-R40T-405			4.0	2.0	40.5	33
F-R30T-405			3.0	1.5	40.5	33
F-R20T-205			2.0	0.8	20.5	13
F-T10H-155	Tungsten carbide	High speed steel	1.0	0.7	15.5	8

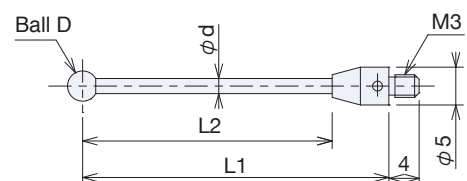

## Outer dimension

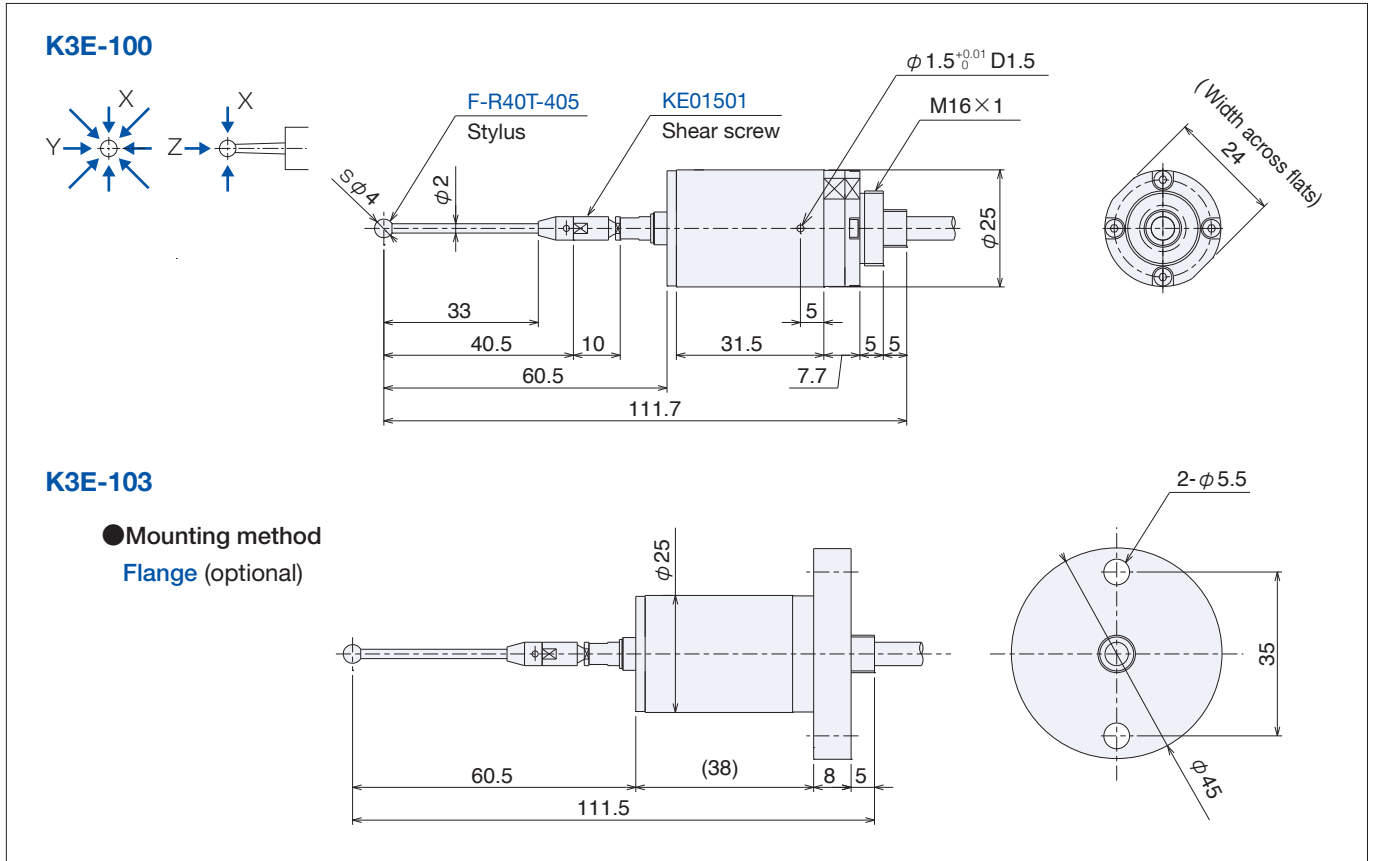

## Specification sheet

E-mail : touchsensor@metrol.co.jp

▼ Please send us your inquiry by fax/e-mail after copying this page, and filling in necessary information. Sample :

Optional specifications (Bold : Standard)

Date:(mm,dd,yy) \_\_\_\_\_

Stylus No. (refer to the left page)	_____ (Standard : <b>F-R40T-405</b> )
I/F unit (Output mode)	<input type="checkbox"/> <b>NO : Nornally open</b> <input type="checkbox"/> NC : Nornally closed
Mouting method	<input type="checkbox"/> <b>M16×1</b> <input type="checkbox"/> Flange

## Cable options

Connector (Refer to P13-4)	<input type="checkbox"/> Not required <input type="checkbox"/> Connector *
Length / Cable protection	<input type="checkbox"/> 5 m <input type="checkbox"/> 10 m    / <input type="checkbox"/> Not required <input type="checkbox"/> Protective tube 4 m <input type="checkbox"/> Wire braid 4 m
* Length / Cable protection when connector is selected	Sensor side    1 m    / <input type="checkbox"/> Not required <input type="checkbox"/> Protective tube 1 m <input type="checkbox"/> Wire braid 1 m
	Machine side <input type="checkbox"/> 5 m <input type="checkbox"/> 10 m    / <input type="checkbox"/> Not required <input type="checkbox"/> Protective tube 4 m <input type="checkbox"/> Wire braid 4 m

Company	
Dept. / Title	
Customer name	
Address	
TEL	
FAX	
E-mail	

### How to order

- 1. Spec sheet**  
Please fill out the specification sheet and send to Metrol.
- 2. Selection**  
The drawing of specific model based on spec sheet is sent.
- 3. Confirmation**  
Check the drawing to select/confirm the specific model.
- 4. Order**  
The quotation is sent and you can place an order.

**E-mail: touchsensor@metrol.co.jp**  
PDF sheet is available for download at [www.metrol.co.jp/en](http://www.metrol.co.jp/en)

FAX: +81-42-528-1442     touchsensor@metrol.co.jp

— Copy this page and use repeatedly —

## K3M

### 3-Dimension (all-round) Type



- Touch probes for CNC Robots are used for measuring of workpiece dimensions, centering and positioning.
- Compatible with high-speed contacts for robots.
- Free of lobing phenomena.

#### Standard specifications

Product name	<b>K3M</b>
Contact structure	NO (Normally open)
Output mode	NC (Normally closed)
Pretravel	X, Y= ±0.4* Z=0.1
Stroke	X, Y=±10* Z=4
Repeatability	0.03 (At operating of speed 500 - 1000mm/min) 0.01 (At operating of speed 100 - 200mm/min)
Contact life time	3 million
Protective structure	IP67
Contact force	X, Y=1N* Z=3N
Contact material	Tungsten carbide ball
Cable	Oil resistant $\phi 5$ / 4cores Tensile strength 30N, Minimum bending R7
LED lamp	Default : LED OFF / Operating : LED ON
Operating temperature range	0°C-60°C (Ice-free)

\* with stylus length of 35.5mm (F635)

#### Circuit diagram

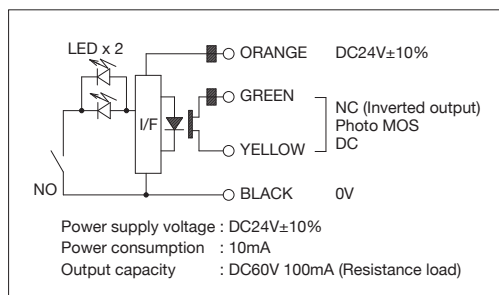

#### Precautions

- Rubber materials used in some products are applicable to water-soluble coolants and alkaline liquids. (Refer to P14-5)
- Operating speed slower than 10mm/min is not recommended.
- Precautions for Touch Probe...P9-7
- Precautions for Sensor Connecting...P13-2
- Technical Guide...P14-1
- Cable Options...P13-4

#### Options

##### Stylus list

D	$\phi d$	L2	Stylus No.					
5	3	within 15		<b>F615</b>	<b>F625</b>	<b>F635</b>	<b>F645</b>	<b>F655</b>
			L1	15.5	25.5	35.5	45.5	55.5
4	2.5	within 15		<b>F614</b>	<b>F624</b>	<b>F634</b>	<b>F644</b>	<b>F654</b>
			L1	15.5	25.5	35.5	45.5	55.5
3	1.8	within 8		<b>F613</b>	<b>F623</b>	<b>F633</b>	<b>F643</b>	
			L1	15.5	25.5	35.5	45.5	
2	1.2	within 5		<b>F612</b>	<b>F622</b>	<b>F632</b>	<b>F642</b>	
			L1	15.5	25.5	35.5	45.5	
			L2	5	5	5	5	

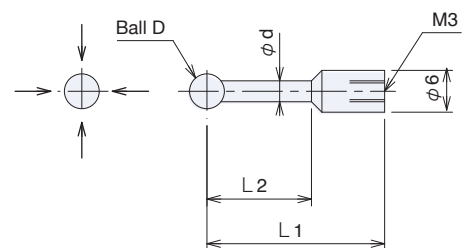

## Outer dimension

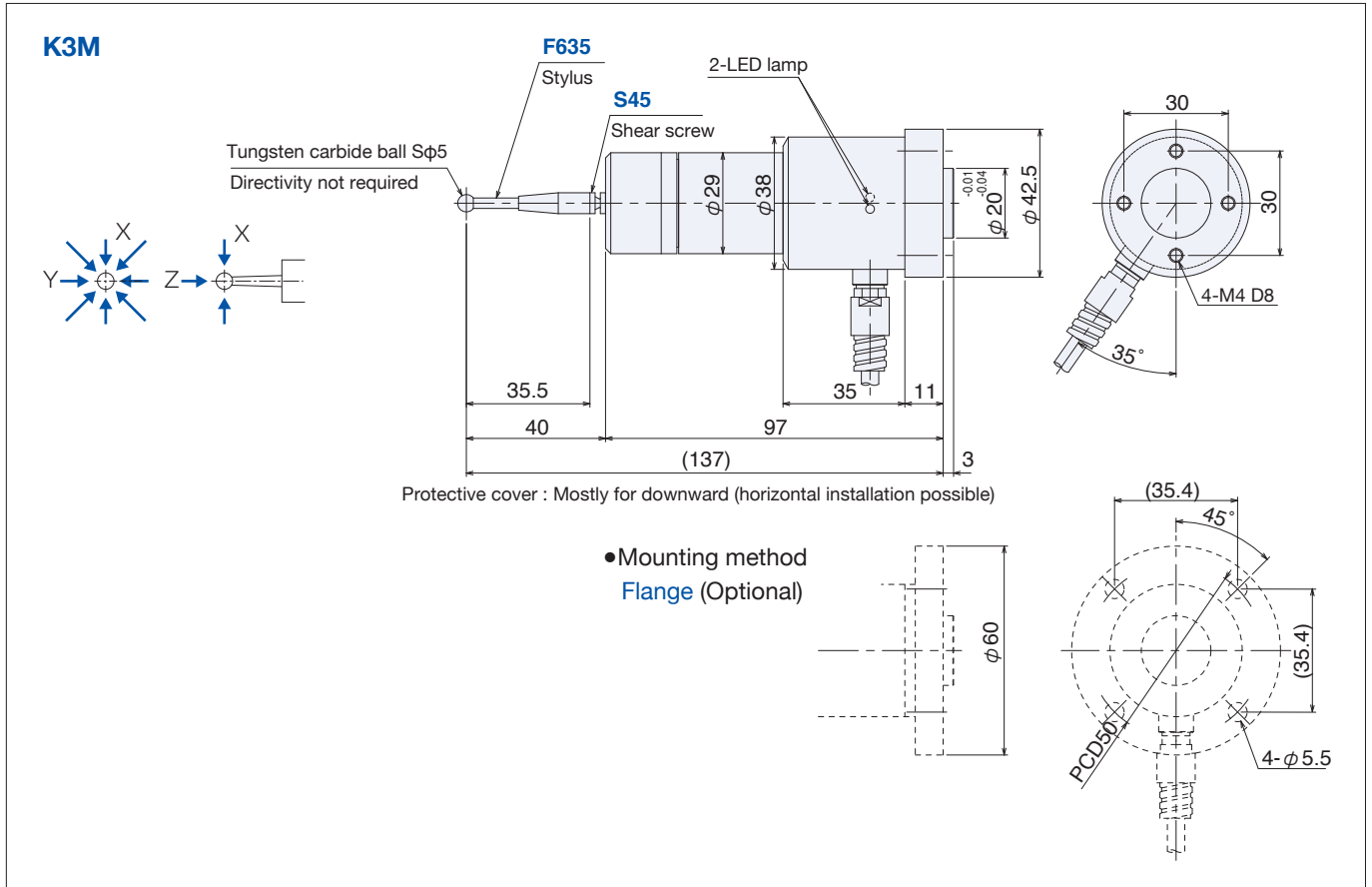

## Specification sheet

E-mail: touchsensor@metrol.co.jp

▼ Please send us your inquiry by fax/e-mail after copying this page, and filling in necessary information. Sample:

Optional specifications (Bold : Standard)

Date:(mm,dd,yy) \_\_\_\_\_

Stylus No. (refer to the left page)	_____ (Standard : <b>F635</b> )
I/F unit (Output mode)	<input type="checkbox"/> <b>NC : Nornally closed</b> <input type="checkbox"/> NO : Nornally open
Mouting method	<input type="checkbox"/> <b>Bottom screw</b> <input type="checkbox"/> Flange

## Cable options

Connector (Refer to P13-4)	<input type="checkbox"/> Not required <input type="checkbox"/> Connector *
Length / Cable protection	<input type="checkbox"/> 5 m <input type="checkbox"/> 10 m    / <input type="checkbox"/> Not required <input type="checkbox"/> Protective tube 4 m <input type="checkbox"/> Wire braid 4 m
* Length / Cable protection when connector is selected	Sensor side    1 m    / <input type="checkbox"/> Not required <input type="checkbox"/> Protective tube 1 m <input type="checkbox"/> Wire braid 1 m
	Machine side <input type="checkbox"/> 5 m <input type="checkbox"/> 10 m    / <input type="checkbox"/> Not required <input type="checkbox"/> Protective tube 4 m <input type="checkbox"/> Wire braid 4 m

Company	
Dept. / Title	
Customer name	
Address	
TEL	
FAX	
E-mail	

## How to order

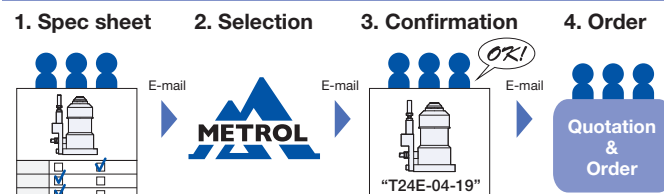

Please fill out the specification sheet and send to Metrol.

The drawing of specific model based on spec sheet is sent.

Check the drawing to select/confirm the specific model.

The quotation is sent and you can place an order.

E-mail: [touchsensor@metrol.co.jp](mailto:touchsensor@metrol.co.jp)

PDF sheet is available for download at [www.metrol.co.jp/en](http://www.metrol.co.jp/en)

FAX: +81-42-528-1442     touchsensor@metrol.co.jp

— Copy this page and use repeatedly —

# K2A

## ±X/Z 3-Direction Type (with pretravel)



■ Touch probes for CNC lathes are reused for measuring inner diameter, outer diameter, and end surfaces.

### Standard specifications

Product name	<b>K2A</b>
Contact structure / Output mode	NC (Normally closed)
Pretravel	X=0.6* Z=0.1
Stroke	X=±8* Z=4
Repeatability	0.001 (Recommended operating speed of 50 - 200mm/min)
Contact life time	3 million
Protective structure	IP67
Contact force	X=1N* Z=2.5N
Contact material	Tungsten carbide ball
Contact rating	DC5V - DC24V Steady Current: 10 mA or less Rush Current: 20 mA or less <b>Limit the LED forward current below 10mA.</b>

Cable	Oil resistant φ5 / 4cores Tensile strength 30N, Minimum bending R7
LED lamp	Default : LED OFF / Operating : LED ON
Operating temperature range	0°C-60°C (Ice-free) (CL-1F Operating temperature range : 0°C-50°C)

\* with stylus length of 35.5mm (F635)

### Precautions

- Rubber materials used in some products are applicable to water-soluble coolants and alkaline liquids. (Refer to P14-5)
- Operating speed slower than 10mm/min is not recommended.

- Precautions for Touch Probe...P9-7
- Precautions for Sensor Connecting...P13-2
- Technical Guide...P14-1
- Cable Options...P13-4

### Options

#### Stylus list

D	φd	L2	Stylus No.					
5	3	within 15		<b>F615</b>	<b>F625</b>	<b>F635</b>	<b>F645</b>	<b>F655</b>
			L1	15.5	25.5	35.5	45.5	55.5
4	2.5	within 15		<b>F614</b>	<b>F624</b>	<b>F634</b>	<b>F644</b>	<b>F654</b>
			L1	15.5	25.5	35.5	45.5	55.5
3	1.8	within 8		<b>F613</b>	<b>F623</b>	<b>F633</b>	<b>F643</b>	
			L1	15.5	25.5	35.5	45.5	
2	1.2	within 5		<b>F612</b>	<b>F622</b>	<b>F632</b>	<b>F642</b>	
			L1	15.5	25.5	35.5	45.5	
			L2	5	5	5	5	

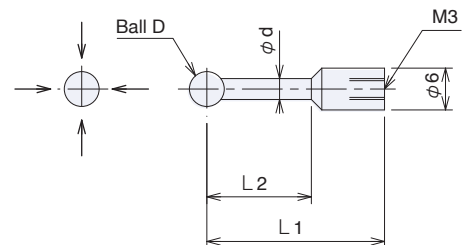

## Touch Probe for CNC Lathe / Special Purpose Machines

### Outer dimension

**K2A**

● Mounting method  
Flange (optional)

● Circuit diagram

**Built-in I/F unit (standard)**

LED  
I/F  
NC

ORANGE DC24V  
GREEN NC (In-phase)  
YELLOW Photo MOS  
BLACK DC  
0V

Power supply voltage : DC24V  
Power consumption : 10mA  
Output : DC60V 100mA (Resistance load)

**External I/F unit (optional)**

K2A CL-1F (Refer to P13-5)

LED  
NC

BROWN +  
BLUE -

DC24V±10%  
In-phase  
Load  
Inverted  
Load  
0V

Power supply voltage : DC24V±10%  
Power consumption : 15mA  
Output capacity : DC200V 100mA  
AC200V 100mA

### Specification sheet

E-mail : touchsensor@metrol.co.jp

▼ Please send us your inquiry by fax/e-mail after copying this page, and filling in necessary information. Sample :

#### Optional specifications (Bold : Standard)

Date:(mm,dd,yy) \_\_\_\_\_

Stylus No. (refer to the left page)	_____ ( Standard : <b>F635</b> )
I/F unit (Output mode)	<input type="checkbox"/> <b>Built-in</b> ( <input type="checkbox"/> <b>NC : Nornally closed</b> <input type="checkbox"/> <b>NO : Nornally open</b> ) <input type="checkbox"/> External <b>CL-1F</b> (Output both NO and NC. Refer to P13-5)
Mouting method	<input type="checkbox"/> <b>Bottom screw</b> <input type="checkbox"/> Flange

#### Cable options

Connector (Refer to P13-4)	<input type="checkbox"/> Not required <input type="checkbox"/> Connector *		
Length / Cable protection	<input type="checkbox"/> 5 m <input type="checkbox"/> 10 m / <input type="checkbox"/> Not required <input type="checkbox"/> Protective tube 4 m <input type="checkbox"/> Wire braid 4 m		
* Length / Cable protection when connector is selected	Sensor side	<input type="checkbox"/> 1 m / <input type="checkbox"/> Not required <input type="checkbox"/> Protective tube 1 m <input type="checkbox"/> Wire braid 1 m	
	Machine side	<input type="checkbox"/> 5 m <input type="checkbox"/> 10 m / <input type="checkbox"/> Not required <input type="checkbox"/> Protective tube 4 m <input type="checkbox"/> Wire braid 4 m	

Company	
Dept. / Title	
Customer name	
Address	
TEL	
FAX	
E-mail	

How to order

**1. Spec sheet**

Please fill out the specification sheet and send to Metrol.

**2. Selection**

The drawing of specific model based on spec sheet is sent.

**3. Confirmation**

Check the drawing to select/confirm the specific model.

**4. Order**

The quotation is sent and you can place an order.

✉ E-mail: [touchsensor@metrol.co.jp](mailto:touchsensor@metrol.co.jp)  
 PDF sheet is available for download at [www.metrol.co.jp/en](http://www.metrol.co.jp/en)

FAX: +81-42-528-1442 ✉ touchsensor@metrol.co.jp

— Copy this page and use repeatedly —



# K2C

## ±X/Z 3-Direction Type (without pretravel)



■ Touch probes for CNC lathes are used for measuring of inner diameter, outer diameter, and end surfaces.

### Standard specifications

Product name	<b>K2C</b>
Contact structure	NC (Normally closed)
Output mode	NC (Normally closed) or NO (Normally open) (when using an external I/F unit <a href="#">CL-1F</a> )
Pretravel	0
Stroke	X=±8* Z=4
Repeatability	0.001 (Recommended operating speed of 50 - 200mm/min)
Contact life time	300,000
Protective structure	IP67
Contact force	X=0.4N* Z=2.5N
Contact material	Tungsten carbide ball
Contact rating	DC5V - DC24V Steady Current: 10 mA or less Rush Current: 20 mA or less <b>Limit the LED forward current below 10mA.</b>

(mm)

Cable	Oil resistant $\phi 5$ / 2 cores Tensile strength 30N, Minimum bending R7
LED lamp	Default : LED ON / Operating : LED OFF
Standard accessory	External I/F unit <a href="#">CL-1F</a> (Refer to P13-5)
Operating temperature range	0°C-60°C (Ice-free) ( <a href="#">CL-1F</a> Operating temperature range : 0°C-50°C)

\* with stylus length of 35.5mm ([F635](#))

### Precautions

- Rubber materials used in some products are applicable to water-soluble coolants and alkaline liquids. (Refer to P14-5)
- Operating speed slower than 10mm/min is not recommended.

- Precautions for Touch Probe...P9-7
- Precautions for Sensor Connecting...P13-2
- Technical Guide...P14-1
- Cable Options...P13-4

### Options

#### Stylus list

D	$\phi d$	L2	Stylus No.					
				<b>F615</b>	<b>F625</b>	<b>F635</b>	<b>F645</b>	<b>F655</b>
5	3	within 15	L1	15.5	25.5	35.5	45.5	55.5
			L2	6.5	15	15	15	15
4	2.5	within 15		<b>F614</b>	<b>F624</b>	<b>F634</b>	<b>F644</b>	<b>F654</b>
			L1	15.5	25.5	35.5	45.5	55.5
			L2	6.5	10	10	10	10
				<b>F613</b>	<b>F623</b>	<b>F633</b>	<b>F643</b>	
3	1.8	within 8	L1	15.5	25.5	35.5	45.5	
			L2	6.5	8	8	8	
2	1.2	within 5		<b>F612</b>	<b>F622</b>	<b>F632</b>	<b>F642</b>	
			L1	15.5	25.5	35.5	45.5	
			L2	5	5	5	5	

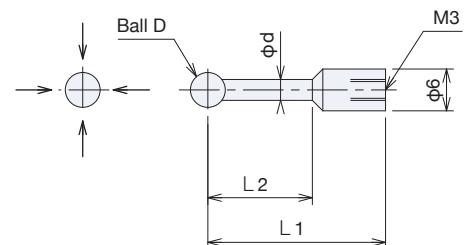



## E2A

### ±X/Z 2-Direction Type

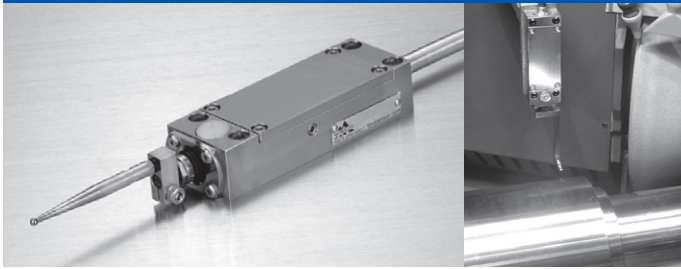

■ Touch probes for CNC cylindrical grinders are used for measurement of workpiece end surfaces.

#### Standard specifications

(mm)

Product name	<b>E2A</b>
Contact structure	NC (Normally closed)
Output mode	NC (Normally closed) or NO (Normally open) (when using an external I/F unit <b>CL-1F</b> )
Pretravel*	Less than 0.5
Stroke*	±7 (Approx. 5°)
Repeatability	0.002(Recommended operating speed of 50 - 200mm/min)
Contact life time	3 million
Protective structure	IP67
Contact force*	1.2N
Contact material	Tungsten carbide ball
Contact rating	DC5V - DC24V Steady Current: 10 mA or less, Rush Current: 20 mA or less Limit the LED forward current below 10mA.
Cable	Oil resistant $\phi 5$ / 4 cores Tensile strength 30N, Minimum bending R7
LED lamp	Default : LED ON / Operating : LED OFF
Standard accessory	External I/F unit <b>CL-1F</b> (Refer to P13-5)
Operating temperature range	0°C-60°C (Ice-free) ( <b>CL-1F</b> Operating temperature range : 0°C-50°C)

#### Precautions

· If grinding powder accumulates on the rubber boot, please rinse with coolant or clean it.

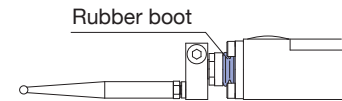

· Rubber materials used in some products are applicable to water-soluble coolants and alkaline liquids. (Refer to P14-5)  
· Operating speed slower than 10mm/min is not recommended.

● Precautions for Touch Probe...P9-7

● Precautions for Sensor Connecting...P13-2

● Technical Guide...P14-1

● Cable Options...P13-4

#### Options

##### Stylus holders (for E2A)

Stylus holder No.		F01	F02	F03	F04	F05
H1		10	15	20	25	30
H2		23.5	28.5	33.5	38.5	43.5

#### Over travel signal

Output mode	NC (Normally closed)
Contact rating	DC24V 20mA(MAX)

\* with stylus length of 54.5mm (**1025D**)

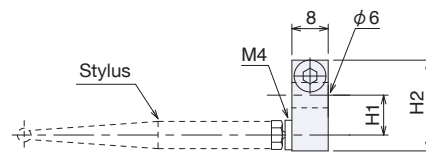

#### Stylus list

D	$\phi d$	L2	Stylus No.					
5	3	within 15		<b>F615</b>	<b>F625</b>	<b>F635</b>	<b>F645</b>	<b>F655</b>
			L1	15.5	25.5	35.5	45.5	55.5
4	2.5	within 15		<b>F614</b>	<b>F624</b>	<b>F634</b>	<b>F644</b>	<b>F654</b>
			L1	15.5	25.5	35.5	45.5	55.5
3	1.8	within 8		<b>F613</b>	<b>F623</b>	<b>F633</b>	<b>F643</b>	
			L1	15.5	25.5	35.5	45.5	
2	1.2	within 5		<b>F612</b>	<b>F622</b>	<b>F632</b>	<b>F642</b>	
			L1	15.5	25.5	35.5	45.5	
			L2	6.5	15	15	15	15
			L2	6.5	10	10	10	10
			L2	6.5	8	8	8	
			L2	5	5	5	5	

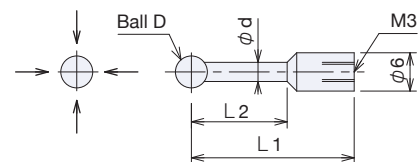

#### 2065D (for E2A only)

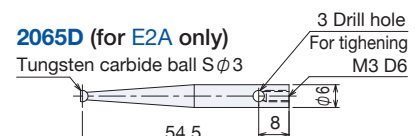

#### F16190 (for E2A only)

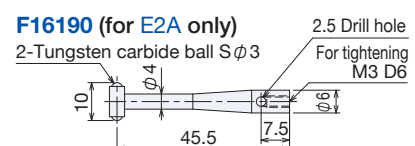

Outer dimension

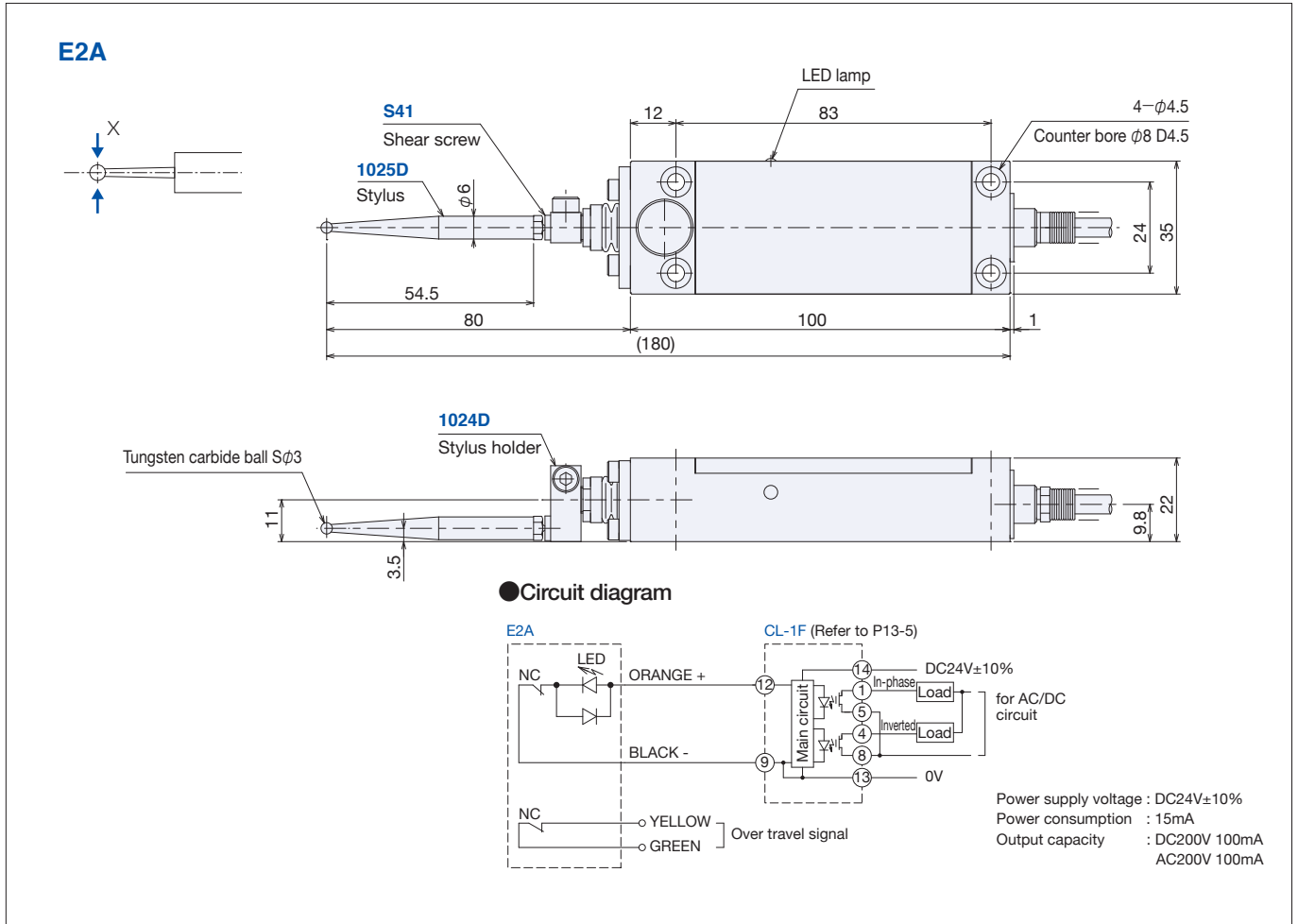

Specification sheet

E-mail : touchsensor@metrol.co.jp

Please send us your inquiry by fax/e-mail after copying this page, and filling in necessary information. Sample :

Optional specifications (Bold : Standard)

Date:(mm,dd,yy) \_\_\_\_\_

Stylus No. (refer to the left page)	_____ ( Standard : <b>F635</b> )
-------------------------------------	----------------------------------

Cable options

Connector (Refer to P13-4)	<input type="checkbox"/> Not required	<input type="checkbox"/> Connector *		
Length / Cable protection	<input type="checkbox"/> 5 m	<input type="checkbox"/> 10 m / <input type="checkbox"/> Not required	<input type="checkbox"/> Protective tube 4 m	<input type="checkbox"/> Wire braid 4 m
* Length / Cable protection when connector is selected	Sensor side	1 m / <input type="checkbox"/> Not required	<input type="checkbox"/> Protective tube 1 m	<input type="checkbox"/> Wire braid 1 m
	Machine side	<input type="checkbox"/> 5 m	<input type="checkbox"/> 10 m / <input type="checkbox"/> Not required	<input type="checkbox"/> Protective tube 4 m

Company	
Dept. / Title	
Customer name	
Address	
TEL	
FAX	
E-mail	

How to order

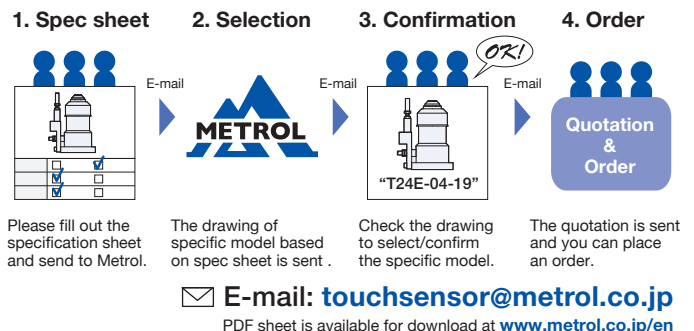

FAX: +81-42-528-1442 ✉ touchsensor@metrol.co.jp

— Copy this page and use repeatedly —

# Tool Setter Series for CNC Machining Centers

## Summary

- Metrol tool setters with built-in "High-precision precisioning position switches" are used in CNC machine tools including CNC machining centers.
- In addition to presetting tool length, tool setters can be used to detect wear and breakage and correct thermal distortion.

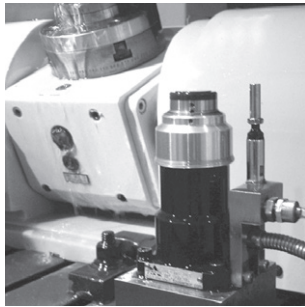

## Features

- 1) As the signal is output by directly contacting the leading edge of the tool, it does not cause false positives and has high reliability.
- 2) The internal switch is of the contact type with high precision (repeatability: 1 μm), and is free of movement differential.
- 3) Since there is no need of an amplifier, there is no temperature drift caused by self-generation and temperature characteristic of the sensor unit.
- 4) Dustproof and waterproof structure has superior durability even under harsh conditions caused by the presence of coolant and cuttings.
- 5) Outputs over-travel warning signal (except for TD1).

## Product List

(mm)

Type	Small Type	Cylindrical Type		
Contact diameter	φ20	φ20	φ40	φ60
Contacting part	Stationary	Stationary	Replaceable	
Stroke	5	12		
Bearing	Metal bearing	Linear bearing		
Over travel signal	Equipped	Equipped		
Output mode	NO	NO/NC		
Product name	<b>TM26D</b>	<b>T24E-120</b>	<b>T24E-240</b>	<b>T24E-260</b>
Page	P10-5	P10-8	P10-9	P10-10

Type	Square Type	Horizontal Installation Type	For Small Diameter Tool Measurement	For Length and Diameter Measurement
Contact diameter	φ20	φ20	φ10	φ20
Contacting part	Stationary	Stationary	Stationary	Replaceable
Stroke	12	6	5	1-2 (depending on directions)
Bearing	Linear bearing		Metal bearing	-
Over travel signal	Equipped		Equipped	Not equipped
Output mode	NO / NC	NO	NC	NO
Product name	<b>T20-120</b>	<b>T26K</b>	<b>P21</b>	<b>TD1</b>
Page	P10-11	P10-13	P10-15	P10-17

Selection Guide

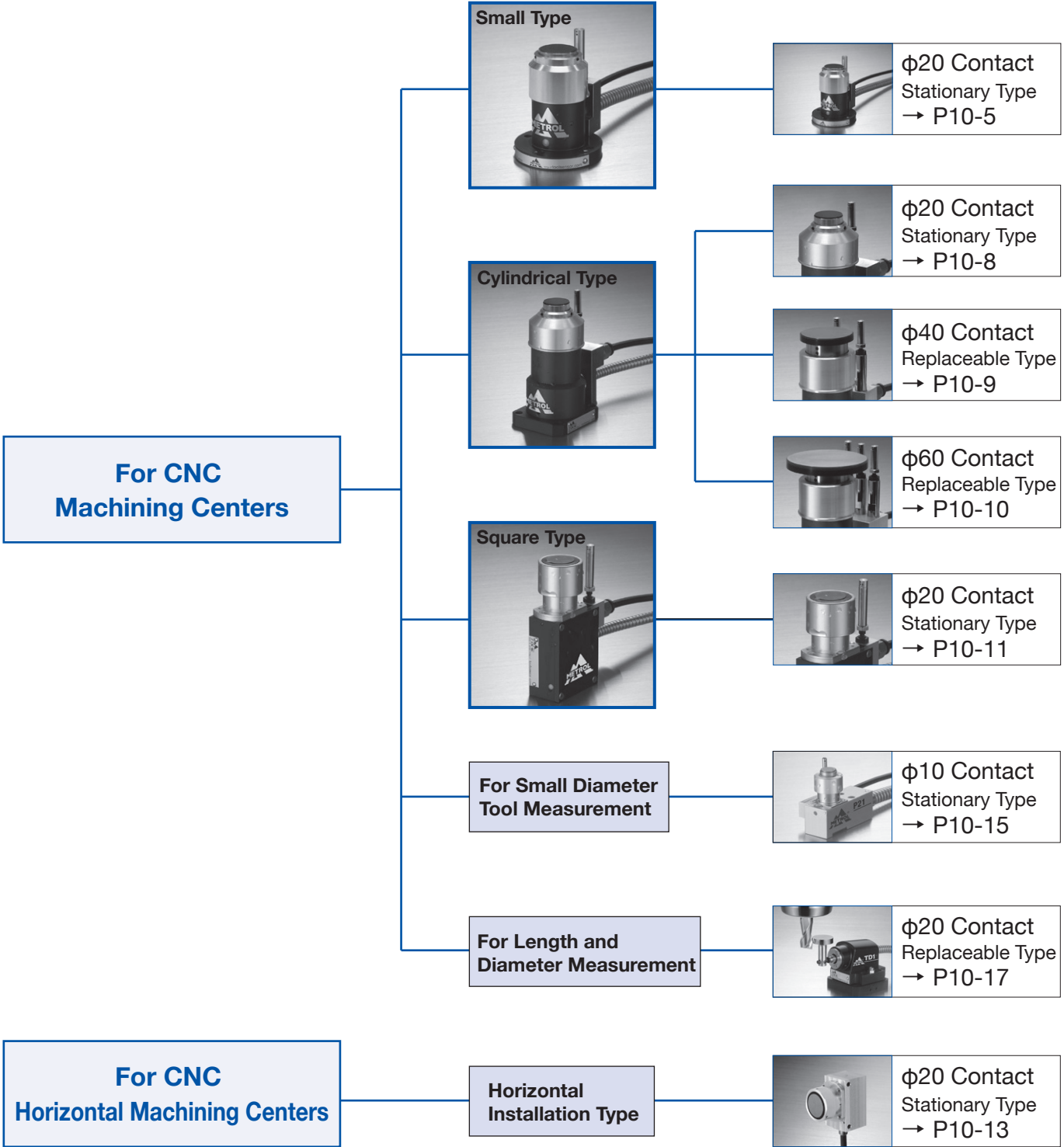



# Tool Setter Selection Parameters and Precautions

## Contacting Part

### 1. Contact Diameter

- Contact diameter can be selected to match the tool (end mill cutter diameter, drill diameter).

### 2. Stationary Contact Type

- The surfaces of stationary contacts are polished following assembly to ensure proper parallelism with the datum mounting surface.
- If the contact surface is worn out or damaged, it must be replaced with the sensor.

### 3. Replaceable Contact Type

- If the contact surface is worn out or damaged, it can be replaced by the customer.
- The user is able to easily make the contact surface parallel again following replacement. (Parallelism can be ensured simply by aligning the parallel mark on the contact when installing.)

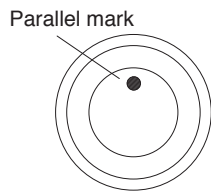

\*Please indicate the "Contact No." or "Product name" when ordering replacement parts.

\*Do not replace a contact with that of different diameter since this can cause a change in contact force.

## Contact Structures (Output mode)

Output mode (Contact structure)	
<b>NC</b> (b contact)	The contact is normally closed ( <b>ON</b> ) and opened during operation ( <b>OFF</b> ). Available with and without pretravel. Fault diagnosis (disconnection, contact trouble) can be performed by interlocking. (fail-safe)
<b>NO</b> (a contact)	Contact normally open ( <b>OFF</b> ). Closed during measurement ( <b>ON</b> ). All NO types have pretravel.

### Circuit diagram

Nomally Closed(NC)

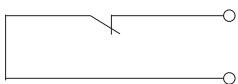

Nomally Open(NO)

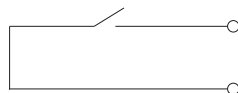

## Pretravel (Distance up to signal point)

### Without pretravel :

When the contact is pushed in, the signal output switches immediately.

As the push-in amount is small, load on the tool will be less.

Vibration and impact may cause chattering.

### With pretravel :

The contact needs to be pushed in by about 0.5 mm until the signal output is switched.

Chattering will occur less even when there is vibration or impact.

## Contact Force

### Amount of force required for contacting part to move from free position to signal point. (Unit :N)

1. The contact force will increase in accordance with the pushing amount of the contact. (depending on the spring constant)
2. Contact force is set in the specified mounting orientation. This mounting orientation is the vertical orientation unless otherwise specified.
3. When using a vertical mounting type in horizontal orientation: Contact force increases by the weight of the movable unit. This requires caution particularly in case of large-diameter contacts and low levels of contact.
4. When using the horizontal mounting type vertically. The contact force decreases according to the weight of the movable part. It may cause the zero reset error.

## Mounting

1. When mounting a tool setter at a right angle to the main axis directly on a table or angle plate, clean the mounting surface and tighten all bolts securely.
2. When using it by moving the tool setter, please be aware of the temperature change, rigidity and the like of the bracket and guide in order to obtain the repeatability of the position (right angle, parallelism) of the contact surface in the measurement position.

## Cables

1. Do not pull on cables with excessive force (up to about 30 N (3 kgf)).
2. The cable bending radius should be R7 or more.
3. Since switch contacts may be damaged by higher current than the rated due to induction of noise and surges, install cables as far away from motor power sources and noise sources as possible (particularly when bundling cables).
4. Do not damage cables during wiring. This can impair water resistance.
5. Cover cables with protective tubes when there is a risk of damage to cables by the usage environment. Minimum bending radius when using protective tubes is R25.



# Tool Setter Selection Parameters and Precautions

## Electrical

1. Contact rating : DC5V - DC24V  
Steady current : 10mA or less (Rush current : 20mA or less)
2. Make electrical connections so that the sensor is grounded when the machine body is grounded.
3. As the sensors with LED have polarity, please be aware of the (+) (-) connection. Recommended value of 10 mA, resistive load.  
When using the sensor with LED, limit the current below 10mA.

## Connectors (Refer to P13-4)

Cables can be branched between the sensor and machine with connectors, thereby facilitating assembly and maintenance. These connectors are also waterproof, and have superior durability.

There are two types of connectors available and both types are rated IP67.

### • Direct-out Connectors

The connector is attached to the sensor head (can not be attached in case of small diameter sensors).

### • Connectors

The connector is attached at a midpoint in the cable (distance from sensor : 1 m)

**Note:** Do not pull the cable when you remove the connector. Push the connector firmly until it tightly fits with O-ring and make sure the protective ring is fastened.

## Air Pipes

1. These pipes are used to blow off cuttings or coolant that have adhered to the contact surface or tool. Oil or debris adhered to the contact surface that cannot be blown off should be periodically removed by cleaning.
2. The threaded coupling on the end of the air pipe is designed to break when subjected to strong impacts by the tool or cuttings.
3. The diameter of the air pathway should be at least  $\phi 2$ .

## Protective Covers (Refer to P14-5)

**Protective covers are for preventing rubber boots form damage, and preventing from impairment of water-resistance and dust proofing caused by metal fragments and other cuttings.**

1. Protective covers are provided as standard specifications.
2. When there is no risk of damage to rubber boots caused by plastic or wooden chips or cuttings, sometimes it may be more effective to wash off any coolant and blow off any debris with air instead of attaching a protective cover boot.
3. Install an extra cover separately so as to avoid direct contact by high-pressure coolant or heavy cuttings.
4. Clean the protective cover when there is the risk of cuttings and other debris having accumulated to where they impair movement or return. (Use caution when blowing off accumulated material with air since this can cause the material to be blown into the protective cover.)

## Proper Tool Contact

1. Ensure that the cutting tool makes contact along a straight line in the direction in which it is pushed.
2. Do not allow the sensor to push in excessively beyond the sensor stroke. The sensor or blade may be damaged if pushed in excessively.
3. When measuring the tool length, touch the contact without rotating the tool.
4. When measuring the tool length, touch the contact upon reversely rotating the tool.
5. Set to a lower speed in the case of a narrow drill diameter ( $\phi 0.5-0.9$  mm).  
However, operating speed slower than 10mm/min is not recommended.
6. Even for the same tool, changing the operation speed or the contact point to the contact will cause errors in accuracy.

**Note:** Please be sure that the operating speed when the contact that has been pushed in is returned to the original state is within the range in which the contact can follow the tool.  
When it is rapidly returned or the tool is shifted horizontally, the internal may be damaged in reaction. Similarly, do not return it rapidly when testing it with a finger during installation, cleaning, etc.

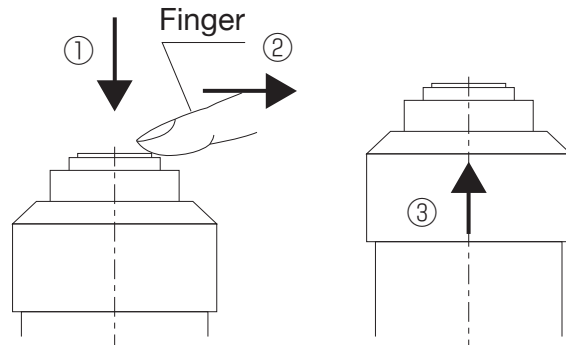

### ●Requesting Quotation

- Send us the quotation request along with attached spec sheet (with additional requirement if any) by Fax/E-mail. FAX: +81 42 528 1442/ Email: touchsensor@metrol.co.jp
- The format (figure number) is determined when the delivery specification figure is submitted.

### ●Ordering Replacement and Spare Parts

- Please specify the product No. (model name) on the nameplate attached to the product.
- Please add an "H" after the product No. when not requiring accessories such as an I/F unit or relay cable (machine side). Please add an "S" when ordering a set.

# TM26D

## φ20 Contact



■ Tool setters for CNC machining centers are used for precise blade positioning, and detection of the wear and breakage.

### Standard specifications

(mm)

Product name	<b>TM26D</b>
Contact diameter	φ20
Contacting part	Stationary type
Surface finishing	Grinding 4s
Contact material	Tungsten carbide
Contact structure	NC (Normally closed)
Output mode	NO (Normally open)
Pretravel	0
Stroke	5
Repeatability	0.001 (Recommended operating speed of 50 - 200mm/min)
Contact life time	3 million
Protective structure	IP67
Contact force	1.5N (Installation position: Vertical)
Cable	Oil resistant φ4.8 / 6 cores Tensile strength 30N, Minimum bending R7
LED lamp	Default : LED OFF / Operating : LED ON
Operating temperature range	0°C-60°C (Ice-free)

### Over travel signal (built-in microswitch)

Output mode	NC (Normally closed) "About 2.5mm from skip signal"
Contact rating	DC24V 100mA resistance load

### Circuit diagram

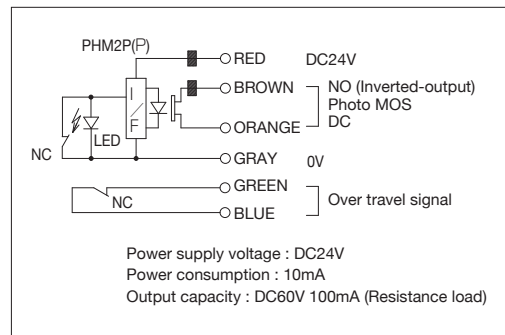

### Precautions

- Although a protective cover is provided with the sensor, an extra cover is needed separately to prevent high pressure coolant or heavy cuttings from entering inside and accumulating in the body.
- Rubber materials used in products are applicable to water-soluble coolants and alkaline liquids. (Refer to P14-5)
- Operating speed slower than 10mm/min is not recommended.

- Tool Setter Selection Parameters and Precautions...P10-3
- Precautions for Sensor Connecting...P13-2
- Cable Options...P13-4
- Technical Guide...P14-1

Outer dimension

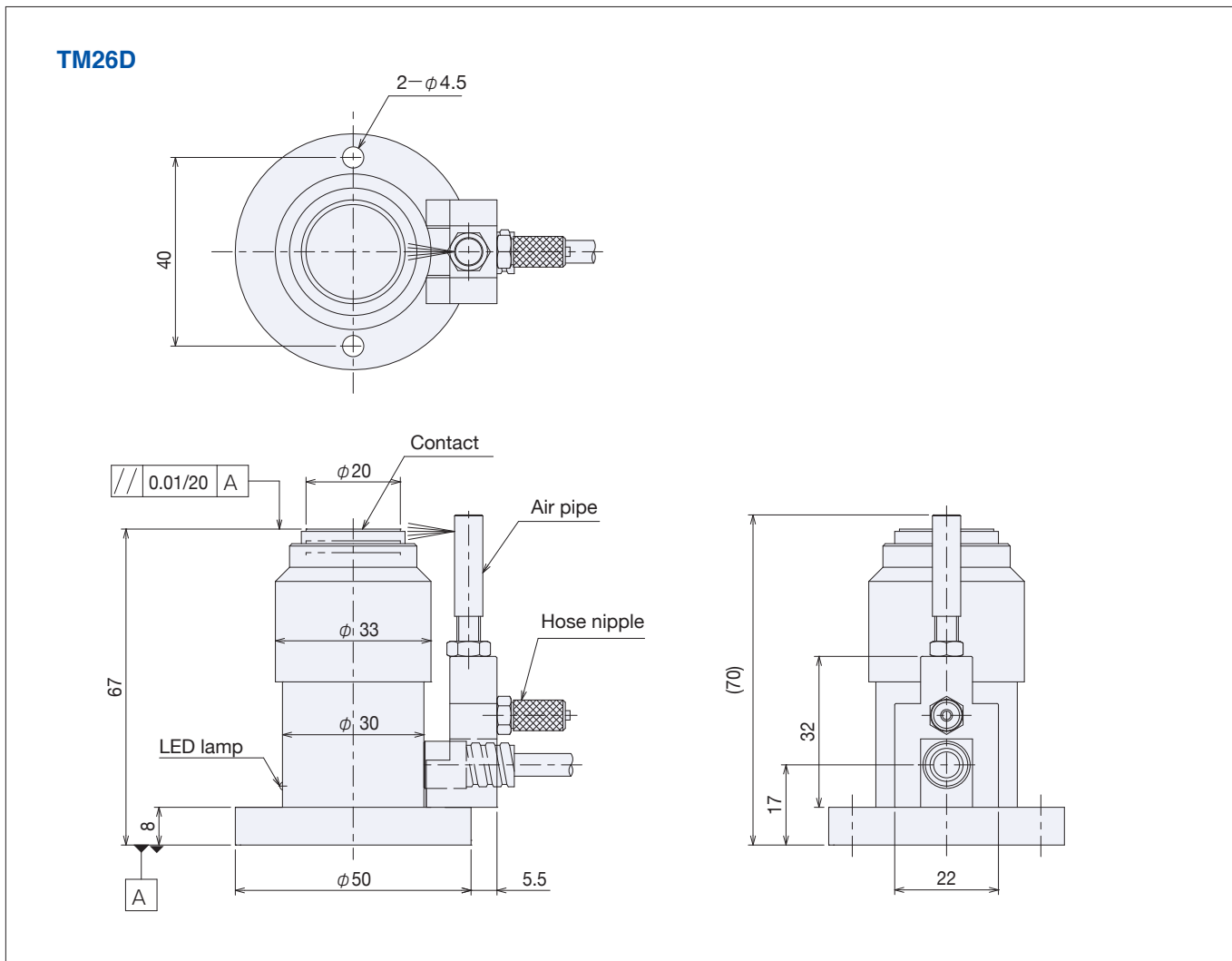

## Specification sheet

E-mail : [touchsensor@metrol.co.jp](mailto:touchsensor@metrol.co.jp)

▼ Please send us your inquiry by fax/e-mail after copying this page, and filling in necessary information. Sample :

### Cable options

Cable length / Cable protection  5m  10m /  Not required  Protective tube 4m

Company	
Dept. / Title	
Name	
Address	
TEL	
FAX	
E-mail	

### How to order

- 1. Spec sheet**  
Please fill out the specification sheet and send to Metrol.
- 2. Selection**  
The drawing of specific model based on spec sheet is sent.
- 3. Confirmation**  
Check the drawing to select/confirm the specific model.
- 4. Order**  
The quotation is sent and you can place an order.

E-mail: [touchsensor@metrol.co.jp](mailto:touchsensor@metrol.co.jp)  
PDF sheet is available for download at [www.metrol.co.jp/en](http://www.metrol.co.jp/en)

FAX: +81-42-528-1442  [touchsensor@metrol.co.jp](mailto:touchsensor@metrol.co.jp)

- Copy this page and use repeatedly. -

# T24E

## φ20 / φ40 / φ60 Contact



■ Tool setters for CNC machining centers are used for precise blade positioning, and detection of the wear and breakage.



### Standard specifications

(mm)

Product name	T24E		
Contact diameter	φ20	φ40	φ60
Contacting part	Stationary type	Replaceable type	
Surface finishing	Grinding 4s		
Contact material	Tungsten carbide		
Contact structure	NC (Normally closed)		
Pretravel	Approx. 0.5		
Stroke	12		
Repeatability	0.001 (Recommended operating speed of 50 - 200mm/min)		
Contact life time	3 million		
Protective structure	IP67		
Contact force	3.8N (Installation position : Vertical)		
Cable	Oil resistant φ5.5 / 6 cores Tensile strength 30N, Minimum bending R7		
LED lamp	Default : LED ON / Operating : LED OFF		
Operating temperature range	0°C-60°C (Ice-free)		

### Circuit diagram

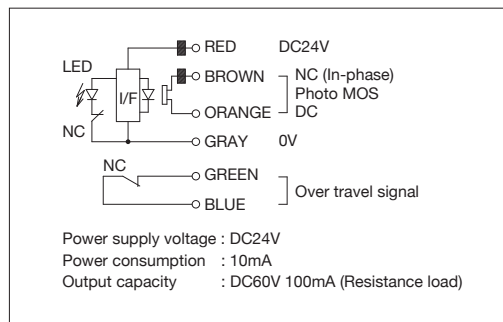

### Precautions

- Although a protective cover is provided with the sensor, an extra cover is needed separately to prevent high pressure coolant or heavy cuttings from entering inside and accumulating in the body.
- Rubber materials used in products are applicable to water-soluble coolants and alkaline liquids. (Refer to P14-5)
- Operating speed slower than 10mm/min is not recommended.

### Over travel signal (built-in microswitch)

Output mode	NC (Normally closed) "About 6mm from skip signal"
Contact rating	DC24V 100mA resistance load

- Tool Setter Selection Parameters and Precautions...P10-3
- Precautions for Sensor Connecting...P13-2
- Cable Options...P13-4
- Technical Guide...P14-1

Outer dimension



T24E-120

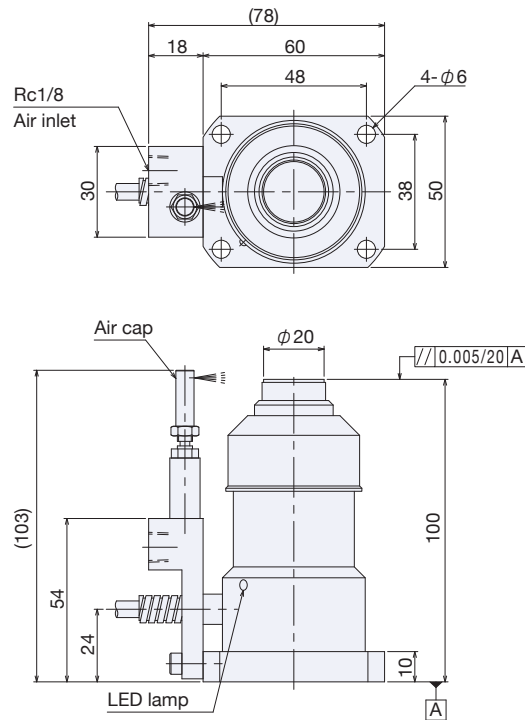

## Specification sheet

E-mail : [touchsensor@metrol.co.jp](mailto:touchsensor@metrol.co.jp)

▼ Please send us your inquiry by fax/e-mail after copying this page, and filling in necessary information. Sample :

Optional specifications (Bold:Standard)

Date:(mm,dd,yy) \_\_\_\_\_

Output mode	<input type="checkbox"/> <b>NC : Normally closed</b> <input type="checkbox"/> NO : Normally open
-------------	--------------------------------------------------------------------------------------------------

### Cable options

Connector (Refer to P13-4)	<input type="checkbox"/> Not required <input type="checkbox"/> Connector *
Length / Cable protection	<input type="checkbox"/> 5 m <input type="checkbox"/> 10 m    / <input type="checkbox"/> Not required <input type="checkbox"/> Protective tube 4 m <input type="checkbox"/> Wire braid 4 m
* Length / Cable protection when connector is selected	Sensor side    1 m    / <input type="checkbox"/> Not required <input type="checkbox"/> Protective tube 1 m <input type="checkbox"/> Wire braid 1 m
	Machine side <input type="checkbox"/> 5 m <input type="checkbox"/> 10 m    / <input type="checkbox"/> Not required <input type="checkbox"/> Protective tube 4 m <input type="checkbox"/> Wire braid 4 m

Company	
Dept. / Title	
Name	
Address	
TEL	
FAX	
E-mail	

### How to order

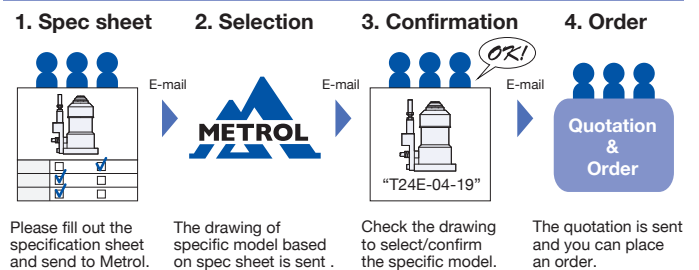

E-mail: [touchsensor@metrol.co.jp](mailto:touchsensor@metrol.co.jp)

PDF sheet is available for download at [www.metrol.co.jp/en](http://www.metrol.co.jp/en)

FAX: +81-42-528-1442    [touchsensor@metrol.co.jp](mailto:touchsensor@metrol.co.jp)

- Copy this page and use repeatedly. -

Outer dimension



T24E-240

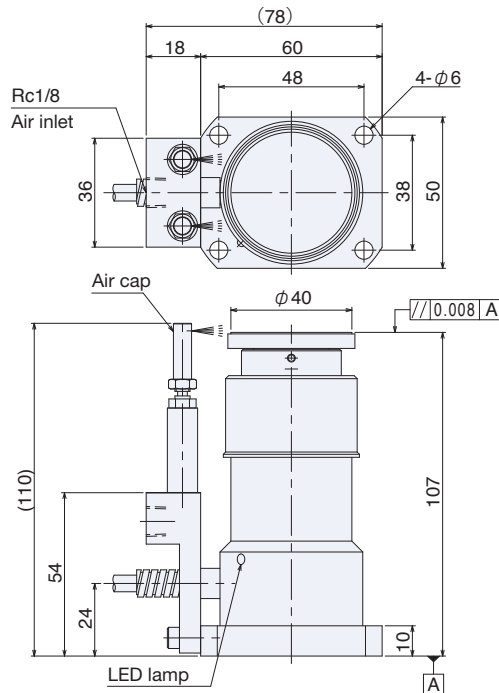

Specification sheet

E-mail : [touchsensor@metrol.co.jp](mailto:touchsensor@metrol.co.jp)

▼Please send us your inquiry by fax/e-mail after copying this page, and filling in necessary information. Sample :

Optional specifications (Bold:Standard)

Date:(mm,dd,yy) \_\_\_\_\_

Output mode	<input type="checkbox"/> <b>NC : Normally closed</b> <input type="checkbox"/> NO : Normally open
-------------	--------------------------------------------------------------------------------------------------

Cable options

Connector (Refer to P13-4)	<input type="checkbox"/> Not required <input type="checkbox"/> Connector *
Length / Cable protection	<input type="checkbox"/> 5 m <input type="checkbox"/> 10 m    / <input type="checkbox"/> Not required <input type="checkbox"/> Protective tube 4 m <input type="checkbox"/> Wire braid 4 m
* Length / Cable protection when connector is selected	Sensor side    1 m    / <input type="checkbox"/> Not required <input type="checkbox"/> Protective tube 1 m <input type="checkbox"/> Wire braid 1 m
	Machine side <input type="checkbox"/> 5 m <input type="checkbox"/> 10 m    / <input type="checkbox"/> Not required <input type="checkbox"/> Protective tube 4 m <input type="checkbox"/> Wire braid 4 m

Company	
Dept. / Title	
Name	
Address	
TEL	
FAX	
E-mail	

How to order

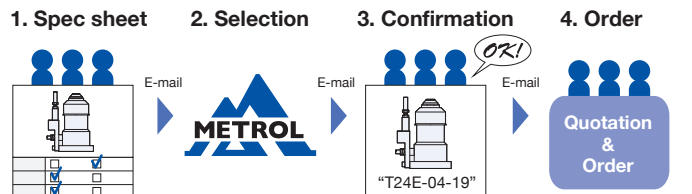

Please fill out the specification sheet and send to Metrol.

The drawing of specific model based on spec sheet is sent.

Check the drawing to select/confirm the specific model.

The quotation is sent and you can place an order.

E-mail: [touchsensor@metrol.co.jp](mailto:touchsensor@metrol.co.jp)

PDF sheet is available for download at [www.metrol.co.jp/en](http://www.metrol.co.jp/en)

FAX: +81-42-528-1442     [touchsensor@metrol.co.jp](mailto:touchsensor@metrol.co.jp)

- Copy this page and use repeatedly. -

Outer dimension



T24E-260

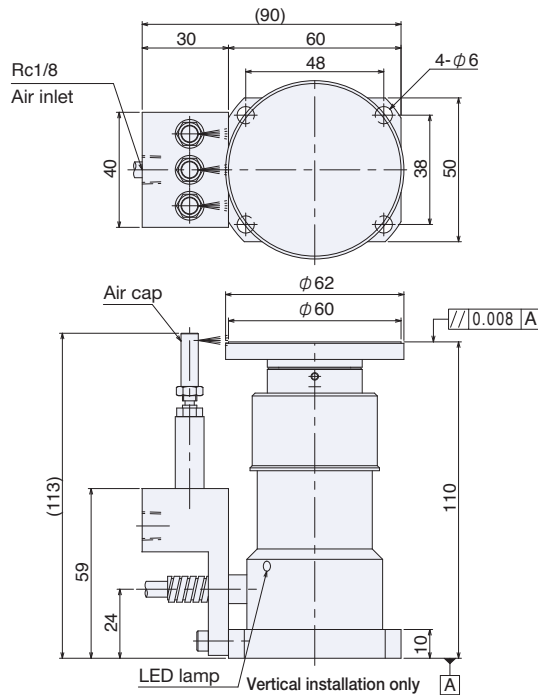

Specification sheet

E-mail : touchsensor@metrol.co.jp

▼ Please send us your inquiry by fax/e-mail after copying this page, and filling in necessary information. Sample :

Optional specifications (Bold:Standard)

Date:(mm,dd,yy) \_\_\_\_\_

Output mode	<input type="checkbox"/> <b>NC : Normally closed</b> <input type="checkbox"/> NO : Normally open
-------------	--------------------------------------------------------------------------------------------------

Cable options

Connector (Refer to P13-4)	<input type="checkbox"/> Not required <input type="checkbox"/> Connector *
Length / Cable protection	<input type="checkbox"/> 5 m <input type="checkbox"/> 10 m    / <input type="checkbox"/> Not required <input type="checkbox"/> Protective tube 4 m <input type="checkbox"/> Wire braid 4 m
* Length / Cable protection when connector is selected	Sensor side    1 m    / <input type="checkbox"/> Not required <input type="checkbox"/> Protective tube 1 m <input type="checkbox"/> Wire braid 1 m
	Machine side <input type="checkbox"/> 5 m <input type="checkbox"/> 10 m    / <input type="checkbox"/> Not required <input type="checkbox"/> Protective tube 4 m <input type="checkbox"/> Wire braid 4 m

Company	
Dept. / Title	
Name	
Address	
TEL	
FAX	
E-mail	

How to order

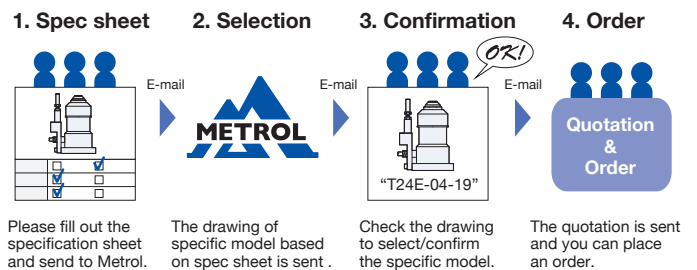

E-mail: touchsensor@metrol.co.jp

PDF sheet is available for download at [www.metrol.co.jp/en](http://www.metrol.co.jp/en)

FAX: +81-42-528-1442    touchsensor@metrol.co.jp

- Copy this page and use repeatedly. -



# T20

## φ20 Contact



■ Tool Setters for CNC machining centers are used for precise blade positioning, and detection of the wear and breakage.



### Standard specifications

(mm)

Product name	<b>T20</b>
Contacting part	Stationary type
Surface finishing	Grinding 4s
Contact material	Tungsten carbide
Contact structure / Output mode	NC (Normally closed)
Pretravel	Approx. 0.5
Stroke	12
Repeatability	0.001 (Recommended operating speed of 50 - 200mm/min)
Contact life time	3 million
Protective structure	IP67
Contact force	3.8N (Installation position : Vertical)
Cable	Oil resistant φ5.5 / 6 cores Tensile strength 30N, Minimum bending R7
LED lamp	Default : LED ON / Operating : LED OFF
Operating temperature range	0°C-60°C (Ice-free)

### Over travel signal (built-in microswitch)

Output mode	NC (Normally closed) "About 6mm from skip signal"
Contact rating	DC24V 100mA resistance load

### Circuit diagram

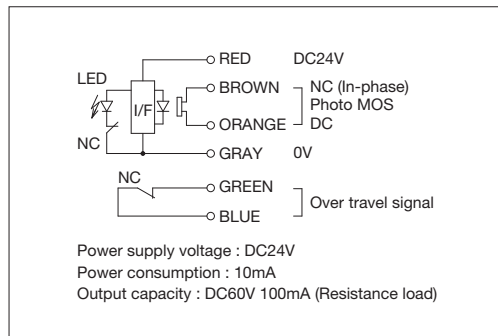

### Precautions

- Although a protective cover is provided with the sensor, an extra cover is needed separately to prevent high pressure coolant or heavy cuttings from entering inside and accumulating in the body.
- Rubber materials used in products are applicable to water-soluble coolants and alkaline liquids. (Refer to P14-5)
- Operating speed slower than 10mm/min is not recommended.

● Tool Setter Selection Parameters and Precautions...P10-3

● Precautions for Sensor Connecting...P13-2

● Cable Options...P13-4

● Technical Guide...P14-1

Outer dimension

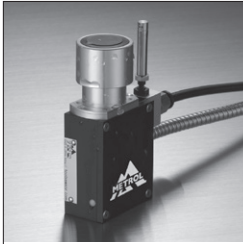

T20-120

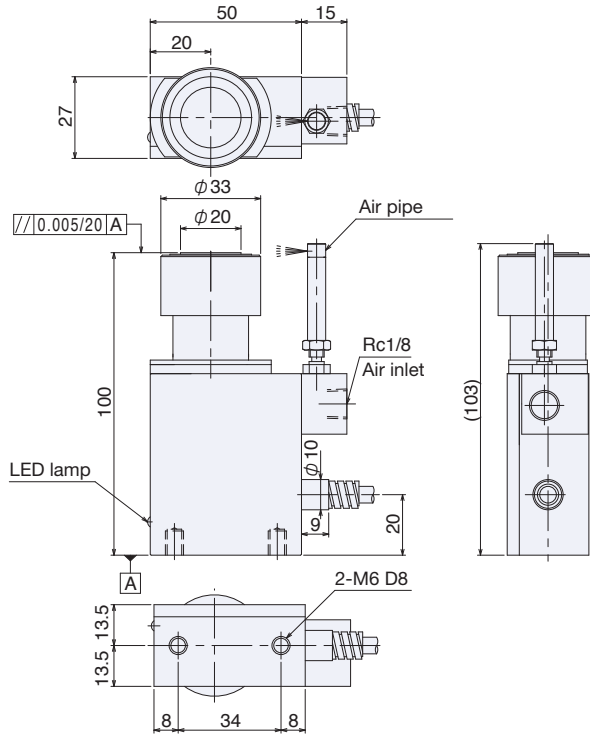

Specification sheet

E-mail : touchsensor@metrol.co.jp

▼ Please send us your inquiry by fax/e-mail after copying this page, and filling in necessary information. Sample :

Optional specifications (Bold:Standard)

Date:(mm,dd,yy) \_\_\_\_\_

Output mode	<input type="checkbox"/> <b>NC : Normally closed</b> <input type="checkbox"/> NO : Normally open
-------------	--------------------------------------------------------------------------------------------------

Cable options

Connector (Refer to P13-4)	<input type="checkbox"/> Not required <input type="checkbox"/> Connector *
Length / Cable protection	<input type="checkbox"/> 5 m <input type="checkbox"/> 10 m    / <input type="checkbox"/> Not required <input type="checkbox"/> Protective tube 4 m <input type="checkbox"/> Wire braid 4 m
* Length / Cable protection when connector is selected	Sensor side    1 m    / <input type="checkbox"/> Not required <input type="checkbox"/> Protective tube 1 m <input type="checkbox"/> Wire braid 1 m
	Machine side <input type="checkbox"/> 5 m <input type="checkbox"/> 10 m    / <input type="checkbox"/> Not required <input type="checkbox"/> Protective tube 4 m <input type="checkbox"/> Wire braid 4 m

Company	
Dept. / Title	
Name	
Address	
TEL	
FAX	
E-mail	

How to order

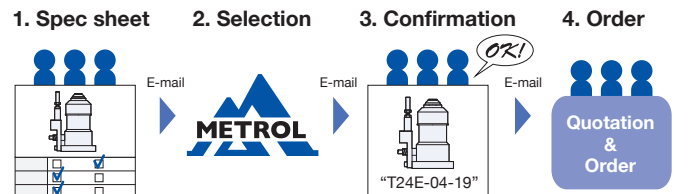

Please fill out the specification sheet and send to Metrol.

The drawing of specific model based on spec sheet is sent.

Check the drawing to select/confirm the specific model.

The quotation is sent and you can place an order.

E-mail: [touchsensor@metrol.co.jp](mailto:touchsensor@metrol.co.jp)

PDF sheet is available for download at [www.metrol.co.jp/en](http://www.metrol.co.jp/en)

FAX: +81-42-528-1442     touchsensor@metrol.co.jp

- Copy this page and use repeatedly. -

# T26K

## φ20 Contact



■ Tool Setters for CNC horizontal machining centers are used for precise blade positioning, and detection of the wear and breakage.

### Standard specifications

(mm)

Product name	<b>T26K</b>
Contact structure	NC (Normally closed)
Output mode	NO (Normally open)
Pretravel	0.5
Stroke	6
Repeatability	0.001 (Recommended operating speed of 50 - 200mm/min)
Contact life time	3 million
Protective structure	IP67
Contact force	2.5N
Contact material	Tungsten carbide
Cable	Oil resistant φ5.5 / 6 cores Tensile strength 30N, Minimum bending R7
LED lamp	Default : LED ON / Operating : LED OFF
Operating temperature range	0°C-60°C (Ice-free)

### Circuit diagram

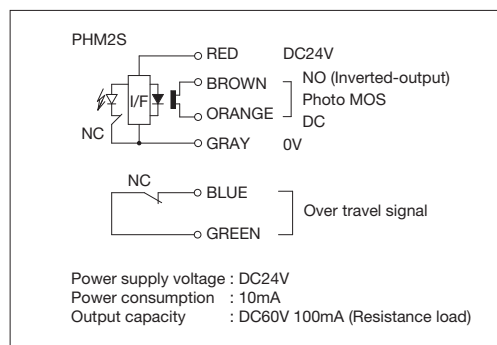

### Precautions

- Although a protective cover is provided with the sensor, an extra cover is needed separately to prevent high pressure coolant or heavy cuttings from entering inside and accumulating in the body.
- Rubber materials used in products are applicable to water-soluble coolants and alkaline liquids. (Refer to P14-5)
- Operating speed slower than 10mm/min is not recommended.

### Over travel signal (built-in microswitch)

Output mode	NC (Normally closed) "About 2.5mm from skip signal"
Contact rating	DC24V 100mA resistance load

- Tool Setter Selection Parameters and Precautions...P10-3
- Precautions for Sensor Connecting...P13-2
- Cable Options...P13-4
- Technical Guide...P14-1

Outer dimension

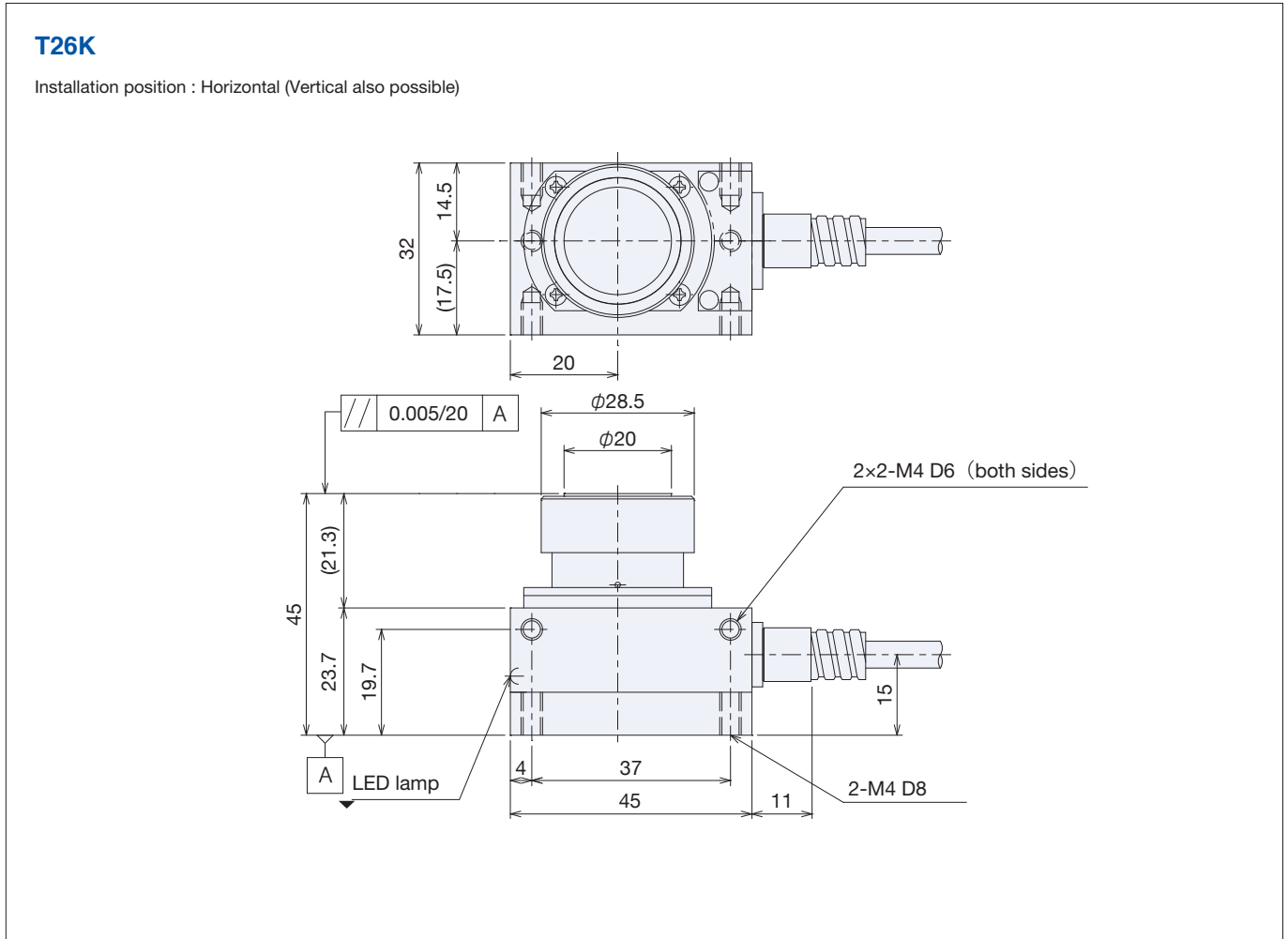

Specification sheet

E-mail : [touchsensor@metrol.co.jp](mailto:touchsensor@metrol.co.jp)

▼ Please send us your inquiry by fax/e-mail after copying this page, and filling in necessary information. Sample :

Cable options

Connector (Refer to P13-4)	<input type="checkbox"/> Not required	<input type="checkbox"/> Connector *		
Length / Cable protection	<input type="checkbox"/> 5 m	<input type="checkbox"/> 10 m / <input type="checkbox"/> Not required	<input type="checkbox"/> Protective tube 4 m	<input type="checkbox"/> Wire braid 4 m
* Length / Cable protection when connector is selected	Sensor side	1 m / <input type="checkbox"/> Not required	<input type="checkbox"/> Protective tube 1 m	<input type="checkbox"/> Wire braid 1 m
	Machine side	<input type="checkbox"/> 5 m	<input type="checkbox"/> 10 m / <input type="checkbox"/> Not required	<input type="checkbox"/> Protective tube 4 m

Company	
Dept. / Title	
Name	
Address	
TEL	
FAX	
E-mail	

**How to order**

- 1. Spec sheet**  
 E-mail  
 Please fill out the specification sheet and send to Metrol.
- 2. Selection**  
 E-mail  
 The drawing of specific model based on spec sheet is sent.
- 3. Confirmation**  
 E-mail  
 Check the drawing to select/confirm the specific model.
- 4. Order**  
 E-mail  
 The quotation is sent and you can place an order.

E-mail: [touchsensor@metrol.co.jp](mailto:touchsensor@metrol.co.jp)  
 PDF sheet is available for download at [www.metrol.co.jp/en](http://www.metrol.co.jp/en)

FAX: +81-42-528-1442 [touchsensor@metrol.co.jp](mailto:touchsensor@metrol.co.jp)

- Copy this page and use repeatedly. -

# P21

## φ10 Contact



- Tool Setters for small CNC machining centers are used for precise blade positioning, and detection of the wear and breakage.
- As the over-travel signal can be output, damage accident can be prevented.
- Equipped with an overcurrent protection board.

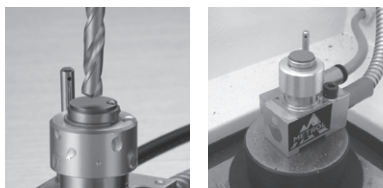

### Standard specifications

(mm)

Product name	<b>P21</b>
Output mode	NC (Normally closed)
Pretravel	0
Stroke	5
Repeatability	0.0005 (Recommended operating speed of 50 -200mm/min)
Contact life time	3 million
Protective structure	IP67
Contact force	1.5N
Contact material	Tungsten carbide
Surface finishing	Grinding 4s
Contact rating	DC5V - DC24V Steady Current: 10 mA or Less Rush Current: 20 mA or Less <b>Limit the LED forward current below 10mA.</b>
Cable	Oil resistant φ3.7 / 4 cores Tensile strength 30N, Minimum bending R7
LED lamp	Default : LED ON / Operating : LED OFF
Operating temperature range	0°C-60°C (Ice-free)

### Circuit diagram

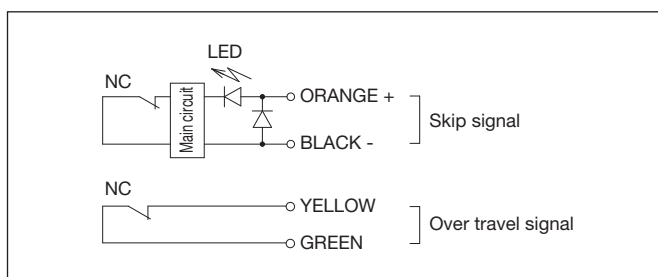

### Precautions

- Although a protective cover is provided with the sensor, an extra cover is needed separately to prevent high pressure coolant or heavy cuttings from entering inside and accumulating in the body.
- Rubber materials used in products are applicable to water-soluble coolants and alkaline liquids. (Refer to P14-5)
- Operating speed slower than 10mm/min is not recommended.

- Tool Setter Selection Parameters and Precautions...P10-3
- Precautions for Sensor Connecting...P13-2
- Cable Options...P13-4
- Technical Guide...P14-1

### Over travel signal (built-in microswitch)

Output mode	NC (Normally closed) "About 2.5mm from skip signal"
Contact rating	DC24V 20mA(Max) (Recommended Value: 10mA) resistance load

Outer dimension

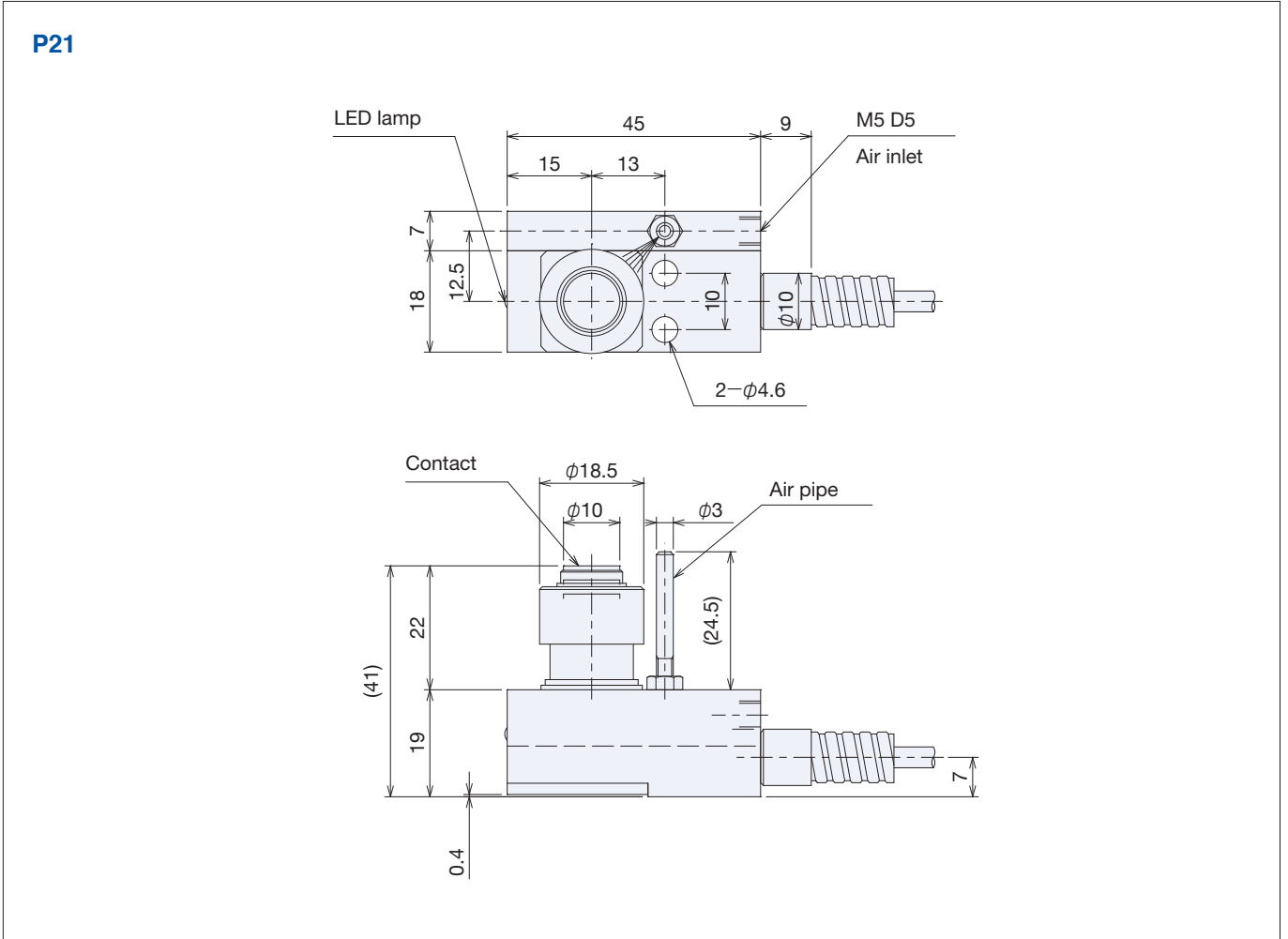

## Specification sheet

E-mail : [touchsensor@metrol.co.jp](mailto:touchsensor@metrol.co.jp)

▼ Please send us your inquiry by fax/e-mail after copying this page, and filling in necessary information. Sample :

Cable options

Date:(mm,dd,yy) \_\_\_\_\_

Cable length / Cable protection	<input type="checkbox"/> 3m	<input type="checkbox"/> 5m	/	<input type="checkbox"/> Not required	<input type="checkbox"/> Protective tube 2m
---------------------------------	-----------------------------	-----------------------------	---	---------------------------------------	---------------------------------------------

Company	
Dept. / Title	
Name	
Address	
TEL	
FAX	
E-mail	

### How to order

- 1. Spec sheet**  

Please fill out the specification sheet and send to Metrol.
- 2. Selection**  

The drawing of specific model based on spec sheet is sent.
- 3. Confirmation**  

Check the drawing to select/confirm the specific model.
- 4. Order**  

The quotation is sent and you can place an order.

E-mail: [touchsensor@metrol.co.jp](mailto:touchsensor@metrol.co.jp)  
 PDF sheet is available for download at [www.metrol.co.jp/en](http://www.metrol.co.jp/en)

FAX: +81-42-528-1442  [touchsensor@metrol.co.jp](mailto:touchsensor@metrol.co.jp)

- Copy this page and use repeatedly. -



# TD1

## φ20 Contact



### φ20 Large Contact Diameter

The contact surface is bigger than conventional swing type products and is adaptable to various tools such as drills, endmills and cutters.

### 10μm Parallelism

The parallelism of the contact is already adjusted 10μm beforehand. Adjusting parallelism is no longer necessary.

### 70% Downsized

Compared to conventional products, its compact design is more suited for an installation in a narrow space.

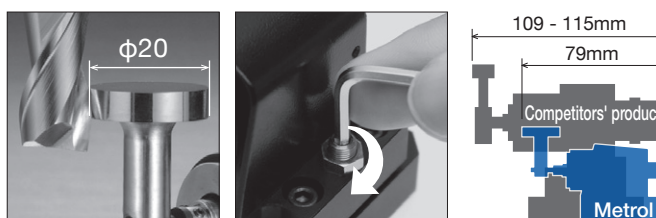

### Standard specifications

(mm)

Product name	<b>TD1</b>
Contact size	φ20×5
Contact material	Tungsten carbide
Contact structure	NC (Normally closed)
Output mode	NO (Normally open)
Pretravel	0
Stroke	+X=2.0 -X=1.0 ±Y=2.0 Z=1.9
Repeatability	0.001 (2σ) (Recommended operating speed of 50 -200mm/min)
Contact life time	300,000
Protective structure	IP67
Contact force	X=1.5N Y=2.0N Z=1.5N
Cable	Oil resistant φ5 / 4 cores Tensile strength 30N, Minimum bending R7
LED lamp	Default : LED ON / Operating : LED OFF
Operating temperature range	0°C-60°C (Ice-free)

### Circuit diagram

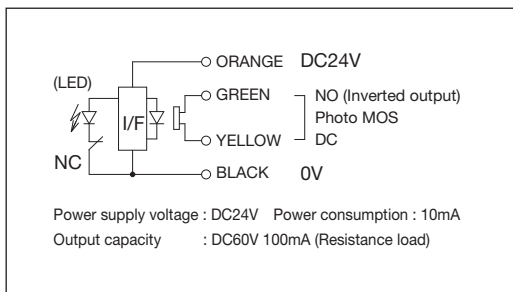

### Precautions

- Although a protective cover is provided with the sensor, an extra cover is needed separately to prevent high pressure coolant or heavy cuttings from entering inside and accumulating in the body.
- Rubber materials used in products are applicable to water-soluble coolants and alkaline liquids. (Refer to P14-5)
- Operating speed slower than 10mm/min is not recommended.

- Tool Setter Selection Parameters and Precautions...P10-3
- Precautions for Sensor Connecting...P13-2
- Cable Options...P13-4
- Technical Guide...P14-1



Outer dimension

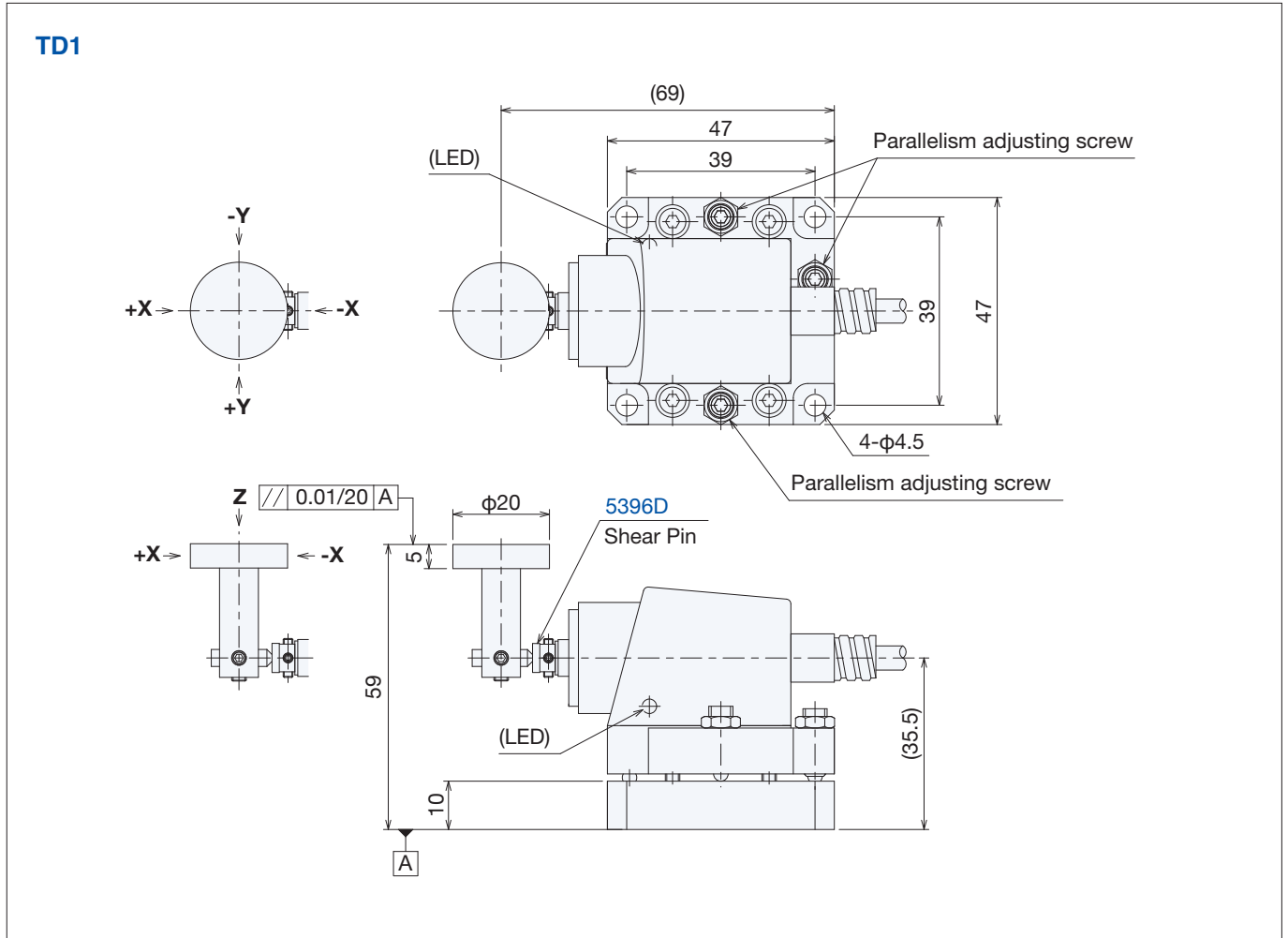

## Specification sheet

E-mail : [touchsensor@metrol.co.jp](mailto:touchsensor@metrol.co.jp)

▼ Please send us your inquiry by fax/e-mail after copying this page, and filling in necessary information. Sample :

### Cable options

Connector (Refer to P13-4)	<input type="checkbox"/> Not required <input type="checkbox"/> Connector *	
Length / Cable protection	<input type="checkbox"/> 5 m <input type="checkbox"/> 10 m   / <input type="checkbox"/> Not required <input type="checkbox"/> Protective tube 4 m <input type="checkbox"/> Wire braid 4 m	
* Length / Cable protection when connector is selected	Sensor side	1 m   / <input type="checkbox"/> Not required <input type="checkbox"/> Protective tube 1 m <input type="checkbox"/> Wire braid 1 m
	Machine side	<input type="checkbox"/> 5 m <input type="checkbox"/> 10 m   / <input type="checkbox"/> Not required <input type="checkbox"/> Protective tube 4 m <input type="checkbox"/> Wire braid 4 m

Company	
Dept. / Title	
Name	
Address	
TEL	
FAX	
E-mail	

### How to order

- 1. Spec sheet**  
 E-mail → METROL
- 2. Selection**  
The drawing of specific model based on spec sheet is sent.
- 3. Confirmation**  
 E-mail → "T24E-04-19"
- 4. Order**  
 E-mail → Quotation & Order

Please fill out the specification sheet and send to Metrol.

The drawing of specific model based on spec sheet is sent.

Check the drawing to select/confirm the specific model.

The quotation is sent and you can place an order.

E-mail: [touchsensor@metrol.co.jp](mailto:touchsensor@metrol.co.jp)  
PDF sheet is available for download at [www.metrol.co.jp/en](http://www.metrol.co.jp/en)

FAX: +81-42-528-1442   [touchsensor@metrol.co.jp](mailto:touchsensor@metrol.co.jp)

- Copy this page and use repeatedly. -

# Tool Setter Series for CNC Lathes

## Summary

- Tool setters for CNC lathes are used to preset the tool bit.
- When a tool bit presses against the contact of the sensor, a signal from an ON-OFF switch demonstrating superior repeatability is output to the CNC or PC to automatically program the bit position. As a result, there is no longer necessary to repeat the process of test cutting, measuring, calculating and inputting to the CNC as in the past, thus the need for tool setting expertise is eliminated, and there are no more concerns over damaging machine due to setting errors.
- Tool bit breakage can be detected and the worn amount can be corrected.

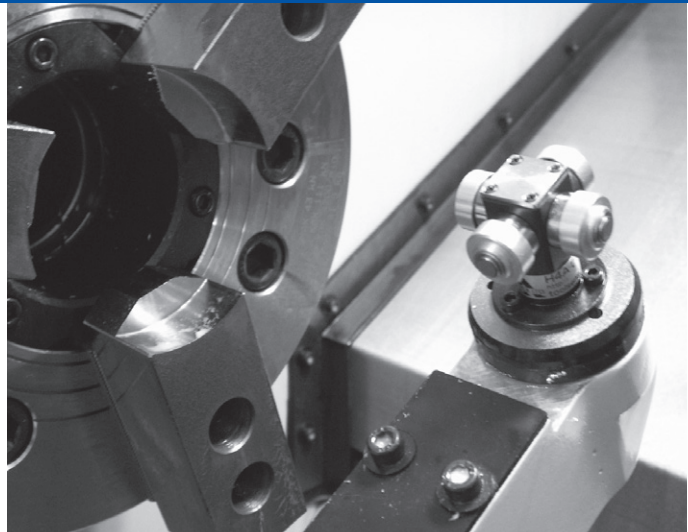

## Features

- 1) As the signal is output by directly contacting the leading edge of the tool, it does not cause false positives and has high reliability.
- 2) The internal switch is of the contact type with high precision (repeatability: 1-2 $\mu$ m), and is free of movement differential.
- 3) Since there is no need of an amplifier, there is no temperature drift caused by self-generation and temperature characteristic of the sensor unit.
- 4) Dustproof and waterproof structure has superior durability even under harsh conditions caused by the presence of coolant and cuttings.

(mm)

Product name	H4A-001	H4E
Features	<ul style="list-style-type: none"> <li>· Linear Type</li> <li>· The number of sensing direction can be selected</li> </ul>	<ul style="list-style-type: none"> <li>· Swing Contact Type</li> <li>· The contact opposite side is the smallest</li> </ul>
No. of detecting direction	1-5	4
Output	Serial	Serial
Repeatability	0.001	0.002 (2 $\sigma$ )
Contact diameter	$\phi$ 5	$\square$ 7 $\times$ 5
Contact opposite side length	40	7
Stroke	2	from 2 (Depending on the shaft length)

## Selection by application

For CNC Lathes

Linear Type

H4A-001



P11-3

Swing Contact Type

H4E



P11-5

## Precautions for Tool Setters for CNC Lathes

### ■ Mounting

- Use the datum surface of the flange in order to attach the contact surface in parallel (in case of angular flange).

### ■ Cables

1. Do not pull on cables with excessive force (up to about 30N (3 kgf)).
2. The cable bending radius should be R7 or more.
3. Since switch contacts may be damaged by the current higher than the rated due to induction of noise and surges, install cables as far away from motor power sources and noise sources as possible (particularly when bundling cables).
4. Do not damage cables during wiring. This can impair water resistance capacity.
5. Cover cables with protective tubes when there is a risk of damaging to cables by the usage environment. Minimum bending radius when using protective tubes is R25.

### ■ Electrical

1. Contact rating: DC5-24V  
Steady current :10mA or less (Rush current : 20mA or less)
2. Make electrical connections so that the sensor is grounded when the machine body is grounded.
3. As the sensors with LED have polarity, please be aware of the (+) (-) connection. Recommended value of 10 mA, resistive load.  
Limit the LED forward current below 10mA.
4. Refer to P4-9 for information on output structure when an interface unit is provided.

### ■ Connector (Refer to P13-4)

Cables can be branched between the sensor and machine with connectors, thereby facilitating assembly and maintenance. These connectors are also waterproof, and have superior durability.

- The connector is attached at a midpoint in the cable (distance from sensor: 1m)

**Note** : Do not pull the cable when you remove the connector. Push the connector firmly until it tightly fits with O-ring and make sure the protective ring is fastened.

### ■ Protective covers (Refer to P14-5)

Protective covers are for preventing rubber boots from damage, and preventing from impairment of water-resistance and dust proofing caused by metal fragments and other cuttings.

1. Protective covers are not provided for some products. In that case, an extra cover is needed to protect rubber boot from damaging by cutting chips.
2. Even for products with boots protective covers, please consider the mounting orientation, direction of the chips and coolant and the like to make sure that chips and

coolant do not get accumulated within the boots protection cover.

### ■ Proper Tool Contact

1. Ensure that the cutting tool makes contact along a straight line in the direction in which it is pushed.
2. Do not allow the sensor to push in excessively beyond the sensor stroke. The sensor or blade may be damaged if pushed in excessively.
3. Set to a lower speed in the case of a narrow drill diameter ( $\phi$  0.5-0.9 mm). However, operating speed slower than 10mm/min is not recommended.
4. Even for the same tool, changing the operation speed or the contact point to the contact will cause errors in accuracy.

**Note** : Please be sure that the operating speed when the contact that has been pushed in is returned to the original state is within the range in which the contact can follow the tool. When it is rapidly returned or the tool is shifted horizontally, the internal may be damaged in reaction. Similarly, do not return it rapidly when testing it with a finger during installation, cleaning, etc.

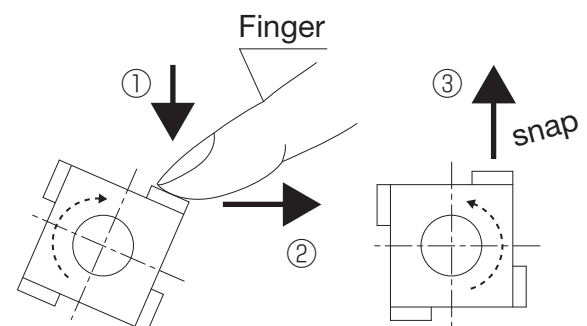

### ● Requesting Quotation

- Send us the quotation request along with attached spec sheet (with additional requirement if any) by Fax/E-mail.  
FAX: +81 42 528 1442/ Email: touchsensor@metrol.co.jp
- The format (figure number) is determined when the delivery specification figure is submitted.

### ● Ordering Replacement and Spare Parts

- Please specify the product name (model name) on the nameplate attached to the product.
- Please add an "H" after the product No. when not requiring accessories such as an I/F unit or relay cable (machine side).

## H4A

### Linear Type

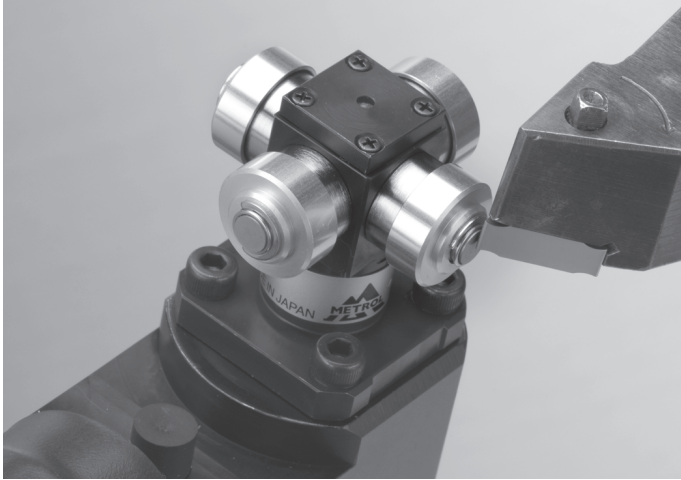

- Tool setters for CNC lathes are used for precise blade positioning, and detection of the wear and breakage.
- Touch sensors are arranged and directly linked in each direction.

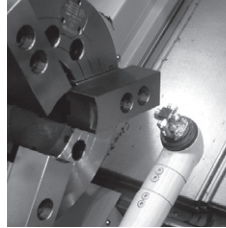

#### Standard specifications

(mm)

Product name	<b>H4A-001</b>
Output mode	NC (Normally closed)
Pretravel	0
Stroke	2
Repeatability	0.001* (Recommended operating speed of 50 - 200mm/min)
Contact life time	3 million
Protective structure	IP67
Contact force	2N
Contact material	Tungsten carbide
Surface finishing	Grinding 4s
Contact rating	DC5V - DC24V Steady Current: 10 mA or Less Rush Current: 20 mA or Less <b>Limit the LED forward current below 10mA.</b>
Cable	Oil resistant $\phi 5$ / 2 cores Tensile strength 30N, Minimum bending R7
LED lamp	Default : LED ON / Operating : LED OFF
Operating temperature range	0°C-60°C (Ice-free)

\* Repeatability of the tool setter alone

#### Circuit diagram

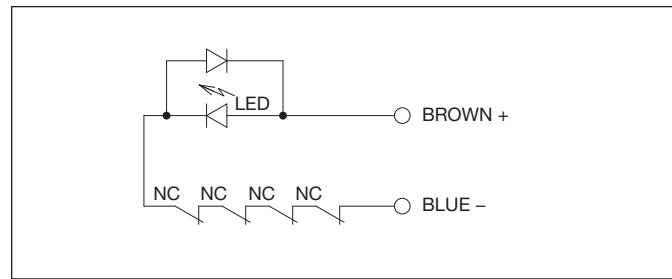

#### Precautions

- Do not press the adjacent contact simultaneously.
- Do not turn the protective cover during cleaning and so forth. The rubber boot inside will not return properly if it becomes twisted.
- Rubber materials used in some products provide protection against water-soluble coolants and alkaline liquids. (Refer to P14-5)

- Precautions for Tool Setters for CNC Lathes...P11-2
- Precautions for Sensor Connecting...P13-2
- Cable Options...P13-4
- Technical Guide...P14-1

Outer dimension

**H4A-001**

Technical drawing of H4A-001 tool setter. Top view shows a square body with dimensions 40x40. Side view shows a height of 30 and a diameter of 16.5. Front view shows a diameter of 23. Callouts include: 1 (top surface), 2 (right side), 3 (bottom surface), 4 (left side), 5 (top cap), 4-Tungsten carbide φ5 (side tip), O-Ring S20 (bottom seal), and LED lamp (bottom center). Surface texture symbols are shown on the top and side surfaces.

● **Protective covers**  
Select a type that prevents coolant from entering through the gap and accumulating inside.

**U type (standard)**  
Upward, sideways

Specification sheet

E-mail : [touchsensor@metrol.co.jp](mailto:touchsensor@metrol.co.jp)

▼ Please send us your inquiry by fax/e-mail after copying this page, and filling in necessary information. Sample :

Optional specifications (Bold:Standard)

Date:(mm,dd,yy) \_\_\_\_\_

No. of detecting direction	1-Direction	<input type="checkbox"/> ①	<input type="checkbox"/> ⑤	
	2-Direction	<input type="checkbox"/> ① ②	<input type="checkbox"/> ① ③	<input type="checkbox"/> ① ⑤
	3-Direction	<input type="checkbox"/> ① ② ③	<input type="checkbox"/> ① ② ⑤	<input type="checkbox"/> ① ③ ⑤
	4-Direction	<input type="checkbox"/> ① ② ③ ④	<input type="checkbox"/> ① ② ③ ⑤	
	5-Direction	<input type="checkbox"/> ① ② ③ ④ ⑤		

Cable options

Connector (Refer to P13-4)	<input type="checkbox"/> Not required	<input type="checkbox"/> Connector *
Length / Cable protection	<input type="checkbox"/> 5 m <input type="checkbox"/> 10 m / <input type="checkbox"/> Not required <input type="checkbox"/> Protective tube 4 m <input type="checkbox"/> Wire braid 4 m	
* Length / Cable protection when connector is selected	Sensor side	1 m / <input type="checkbox"/> Not required <input type="checkbox"/> Protective tube 1 m <input type="checkbox"/> Wire braid 1 m
	Machine side	<input type="checkbox"/> 5 m <input type="checkbox"/> 10 m / <input type="checkbox"/> Not required <input type="checkbox"/> Protective tube 4 m <input type="checkbox"/> Wire braid 4 m

Company	
Dept. / Title	
Name	
Address	
TEL	
FAX	
E-mail	

How to order

**1. Spec sheet**

Please fill out the specification sheet and send to Metrol.

**2. Selection**

The drawing of specific model based on spec sheet is sent.

**3. Confirmation**

Check the drawing to select/confirm the specific model.

**4. Order**

The quotation is sent and you can place an order.

✉ E-mail: [touchsensor@metrol.co.jp](mailto:touchsensor@metrol.co.jp)  
PDF sheet is available for download at [www.metrol.co.jp/en](http://www.metrol.co.jp/en)

FAX: +81-42-528-1442 ✉ [touchsensor@metrol.co.jp](mailto:touchsensor@metrol.co.jp)

- Copy this page and use repeatedly. -

## H4E

### Swing Contact Type



- Tool setters for CNC lathe are used for precise tool bit positioning, and detection of the wear and breakage.
- A type which opposite side size of the contact has been reduced to the maximum and can swing in 4 directions.

#### Standard specifications

(mm)

Product name	<b>H4E</b>
Output mode	NC (Normally closed)
Pretravel	0
Stroke	±2
Repeatability	0.002 (2σ)* (Recommended operating speed of 50 - 200mm/min)
Contact life time	300,000
Protective structure	IP67
Contact force	1.6N
Contact material	Tungsten carbide
Surface finishing	Grinding 4s
Contact rating	DC5V - DC24V Steady Current: 10 mA or Less Rush Current: 20 mA or Less <b>Limit the LED forward current below 10mA.</b>
Cable	Oil resistant φ5 / 2 cores Tensile strength 30N, Minimum bending R7
LED lamp	Default : LED ON / Operating : LED OFF
Operating temperature range	0°C-60°C (Ice-free)

\* Repeatability of the tool setter alone

#### Circuit diagram

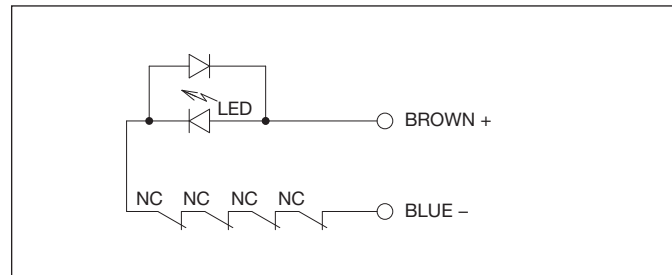

#### Precautions

- As the built-in contact serves as a swing fulcrum, excessive operation speed will accelerate the deterioration of the contacts. In addition, as the contact material with low electrical resistance cannot be used, it needs to be energized only during measurement to protect the contact life.
- Please do not forcefully press the contact to the operating limits. Also, do not press it from the top to the bottom.
- Operating speed slower than 10mm/min is not recommended.

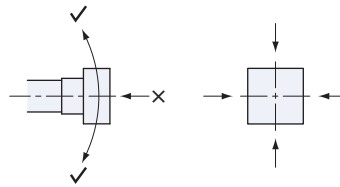

- Precautions for Tool Setters for CNC Lathes...P11-2
- Precautions for Sensor Connecting...P13-2
- Cable Options...P13-4
- Technical Guide...P14-1



Outer dimension

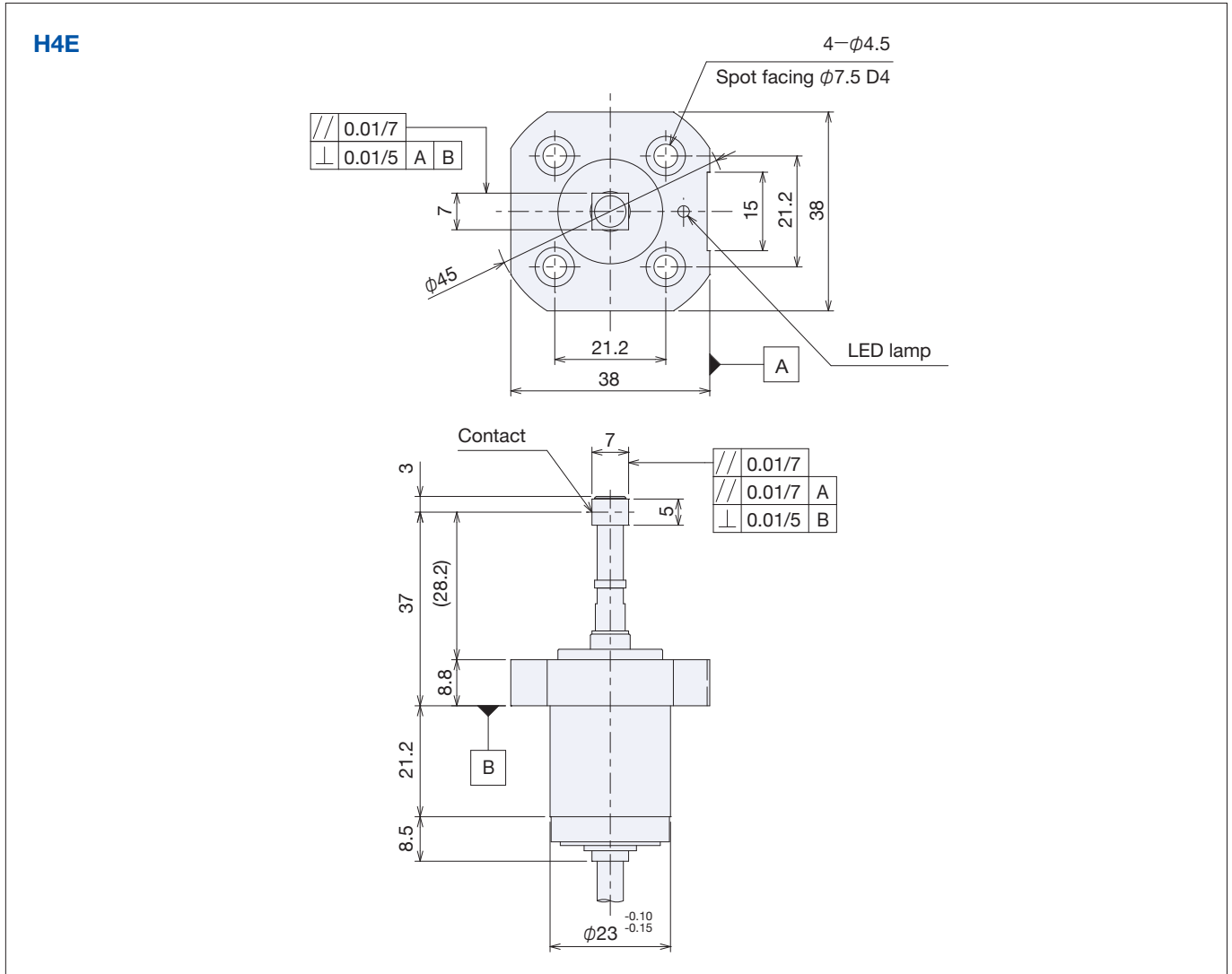

Specification sheet

E-mail : touchsensor@metrol.co.jp

Please send us your inquiry by fax/e-mail after copying this page, and filling in necessary information. Sample :

Cable options

Connector (Refer to P13-4)	<input type="checkbox"/> Not required	<input type="checkbox"/> Connector *		
Length / Cable protection	<input type="checkbox"/> 5 m	<input type="checkbox"/> 10 m / <input type="checkbox"/> Not required	<input type="checkbox"/> Protective tube 4 m	<input type="checkbox"/> Wire braid 4 m
* Length / Cable protection when connector is selected	Sensor side	1 m / <input type="checkbox"/> Not required	<input type="checkbox"/> Protective tube 1 m	<input type="checkbox"/> Wire braid 1 m
	Machine side	<input type="checkbox"/> 5 m	<input type="checkbox"/> 10 m / <input type="checkbox"/> Not required	<input type="checkbox"/> Protective tube 4 m

Company	
Dept. / Title	
Name	
Address	
TEL	
FAX	
E-mail	

How to order

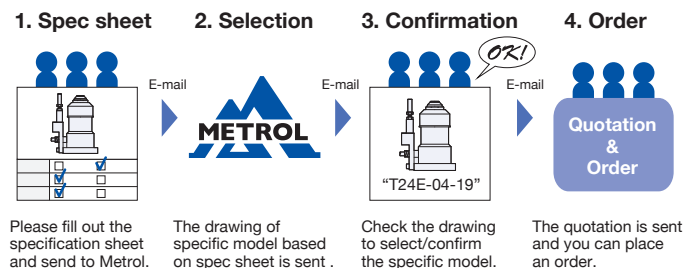

E-mail: touchsensor@metrol.co.jp

PDF sheet is available for download at www.metrol.co.jp/en

FAX: +81-42-528-1442 touchsensor@metrol.co.jp

- Copy this page and use repeatedly. -



## DFM3

### Pneumatic Drive Type



The drill bit breakage detection sensors can be installed on automated and dedicated machine tools for detecting drill bit breakage by contacting a drill, tap, reamer or other tools.

#### Differences from conventional drill bit breakage detection methods

##### Outstanding durability in harsh environments containing cuttings and coolant

The world's first pneumatic drive, motor-free control system eliminates malfunctions caused by coolant.

Protective structure: IP67

#### Mechanical specifications (Sensor body)

Product name	<b>DFM3</b>
Drive method	Pneumatic drive type (single-action push-out air cylinder type)
Signals	3 signals (refer to timing chart on P12-3)
Protective structure	IP67
Direction of needle rotation	Clockwise/counterclockwise
Stroke (rotation angle)	100°
Contact force	0.1N (Static load at a distance of 100 mm from center of rotation, inertial force not included)

Minimum tool diameter	φ0.5mm For small diameter drill bits (1mm or less), refer to p.12-3
Operating temperature range	0-60°C
Working air pressure	0.4 to 0.5 MPa (dry air) Air tube diameter: 4 x 2.5
Needle specifications	Length : 100 mm (from center of rotation) Thickness : 1.5mm Material : Quenched SUS420 HRC50
Cable	Oil resistant φ4 / 5 cores, 3m
Net weight	Approx. 250 g

#### Electrical specifications (Connection unit)

Type	C-DF-01N	C-DF-01P
Output specification	NPN	PNP
	Open collector	
Power supply voltage	DC +24V	
Current consumption	10mA	

LED display	Origin: green Judgment: red, Stroke end: yellow
Output rating	DC24V 150mA (MAX)
Insulation resistance	100mΩ with DC 250V megger
Withstand voltage	AC 500V, 50/60Hz for 1 minute between each pin and case
Protective circuits	Reversed power connection protection, surge protection

#### Ordering format (including options)

① Type	② Rotation direction	③ Needle	④ Protective cover	⑤ Cable	⑥ Cable protection	⑦ Connection unit	⑧ Rubber material
<b>DFM3</b>	<b>R</b> : Clockwise (right) <b>L</b> : Counter clockwise (left) (as viewed from the top)	Blank: Standard φ 1.5x100mm <b>B8</b> : 80mm <b>B12</b> : 120mm <b>B14</b> : 140mm <b>B16</b> : 160mm* <b>F8</b> : Flat 80mm (Mostly for rotary drills) <b>F10</b> : Flat 100mm	Blank: For downward installation <b>U</b> : For upward installation	Blank: 3m cable <b>5</b> : 5m	<b>Blank</b> : Not required <3m cable> <b>W2</b> : 2m wire braid  <5m cable> <b>W4</b> : 4m wire braid	<b>N</b> : C-DF-01N <b>P</b> : C-DF-01P <b>H</b> : Not required  When purchasing a sensor unit only.	<b>V</b> : For oil/water-soluble coolant

\* Please refer to P12-3 "Precautions Regarding Special Specifications" when selecting 160mm needle(**B16**).

(Order examples1)

**DFM3-R-N-V**

① ② ⑦ ⑧

(Order examples2)

**DFM3-R-B8U-5W4-H-V**

① ② ③ ④ ⑤ ⑥ ⑦ ⑧

## Structure ■ Operation

The drive unit of this sensor drives the needle starting at the origin position when an origin signal is switched ON (LED green), and discontinues driving the needle at the stroke end position when the end signal is switched ON (LED yellow).

**When the drill bit has broken (or is not present)**, the needle rotates to the stroke end position, a judgment signal is switched to OFF and the LED red goes out.

**If the drill bit is normal**, since the needle does not reach the stroke end position as a result of contacting the drill bit and stopping, the judgment signal remains ON and the red LED lights.

The presence or absence of drill bit breakage can be determined by transmitting the ON or OFF status of the judgment signal (LED red lit or unlit) to an external device when the stroke end signal is ON (yellow LED lit). \*Regardless of the presence/absence of breakage, the stroke end signal is switched ON everytime the needle stops.

## Names of components and internal structure

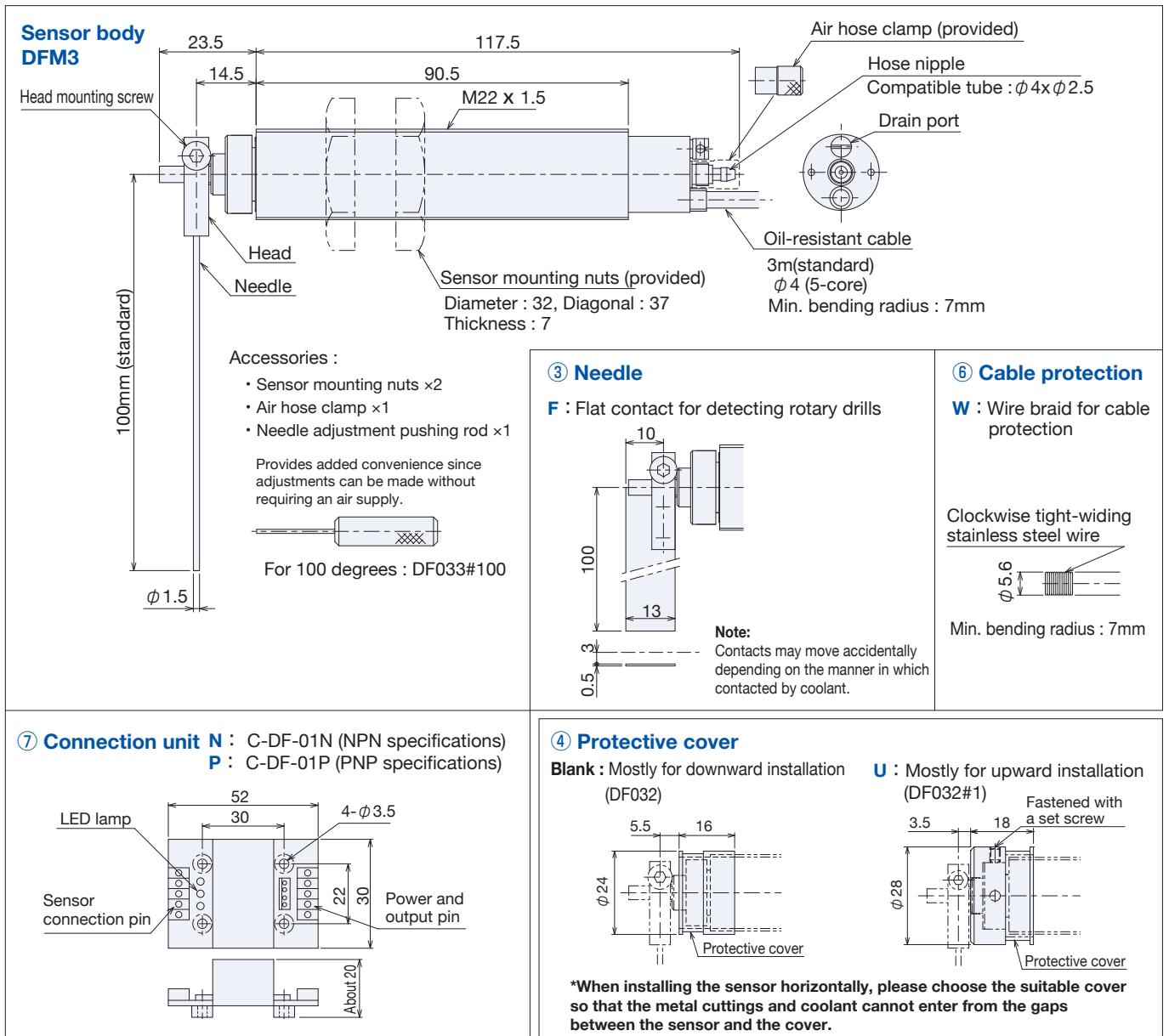

## Electrical and air circuit drawings

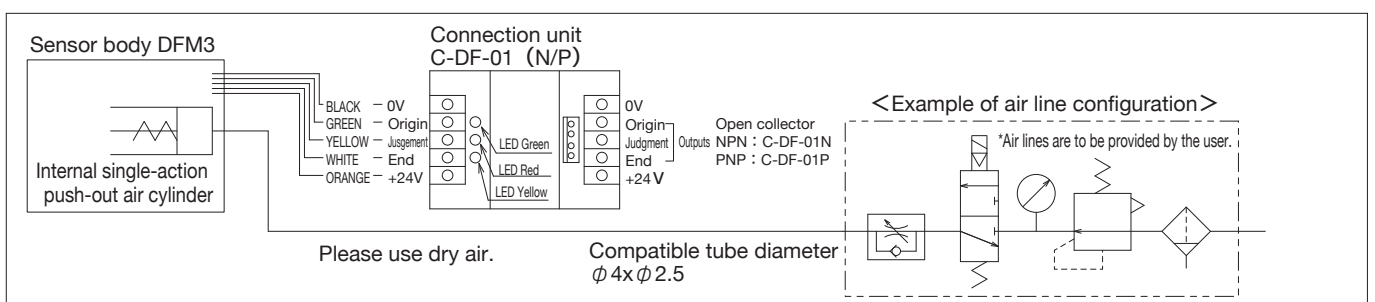

## Signal Setting Procedure

### Needle position (angle) and sensor operation (Clockwise rotation)

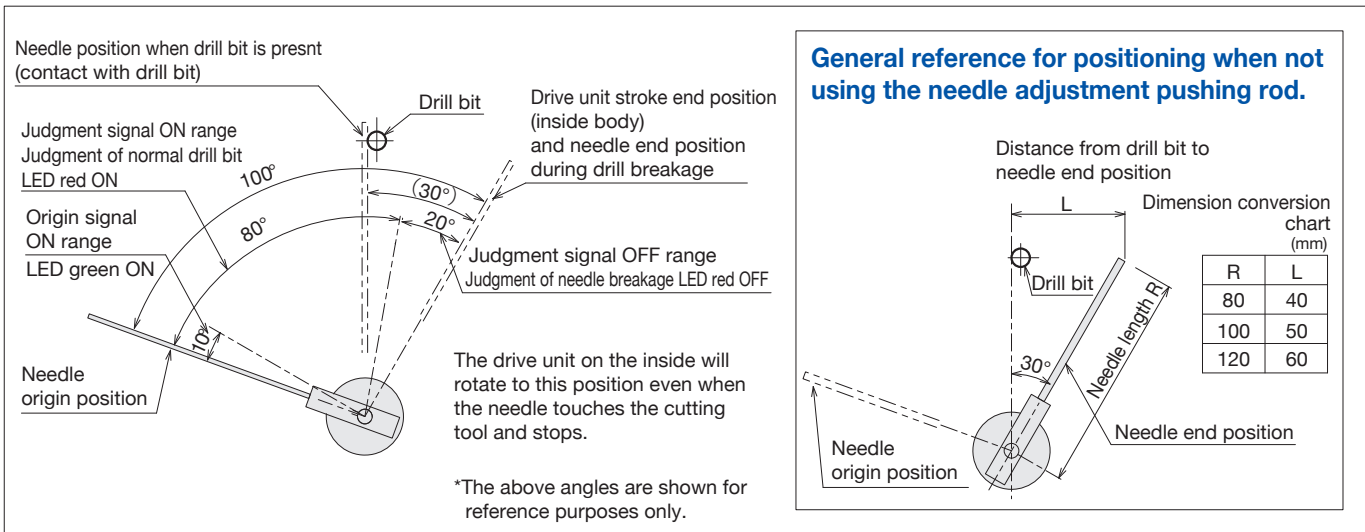

### Electrical control method

- Input the air after confirming that the needle is at the origin position by checking the Origin signal.
- Confirm with the Stroke end signal whether the needle rotates properly and reaches to the end position.
- Confirm with the Judgment signal whether a tool is present or broken. Confirmation of the Judgment signal must be done a second after the Stroke end signal is ON.

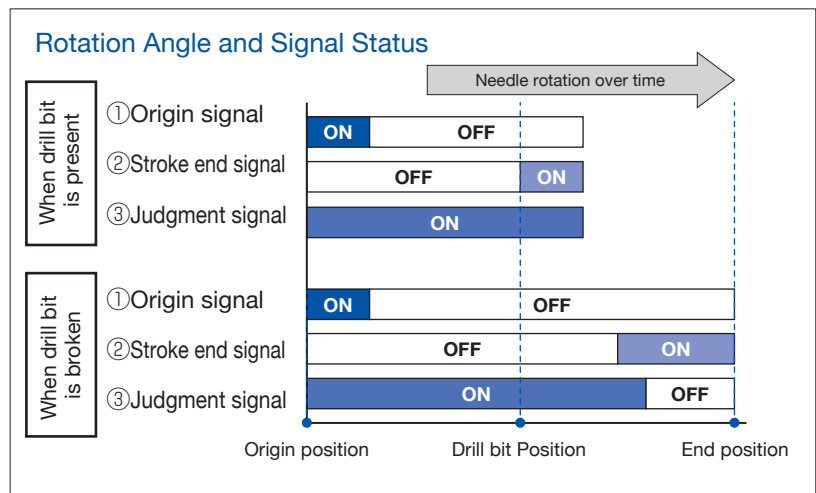

## Precautions Regarding Special Specifications

### Note1 : Precautions when detecting small diameter drill bits ( $\phi 1\text{mm}$ or less)

- The contact force of the needle when it meets the drill bit is the sum of the inertial force resulting from rotation added to the spring pressure of the sensor (0.1N for a needle length of 100mm). In order to eliminate the effects of this inertial force, reduce speed with a speed controller.
- Please consult us when it is necessary to reduce the sensor spring pressure itself (such as when desiring to minimize deflection of the drill bit).

### Note2 : Precautions when needle length 160mm

- Chattering signals may occur due to the rebound caused by the inertia of the needle when the needle is stopped at the starting position or stroke end position after rotating. It is recommended to take countermeasures to avoid this effect such as by using a timer for electrical processing.
- When using the sensor in the horizontal direction, avoid using an installation such that the needle starting position falls within the range indicated by diagonal lines in the drawing at right. Since return force is attributable to the spring, the moment load of the needle increases in the case of a long needle, which may prevent it from completely returning to the starting position.

### Case of horizontal sensor installation with a needle length of 160mm

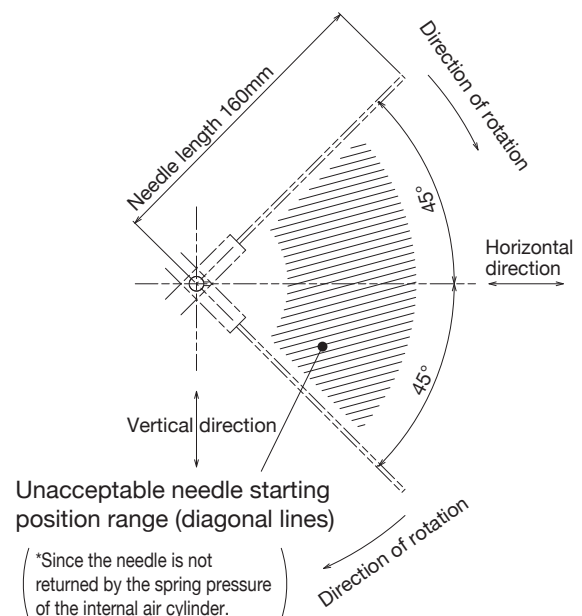

## Installation and Signal Adjustment

### 1. Mounting of sensor body

- 1) Temporarily install the sensor body (M22 x 1.5) on the mounting bracket provided by the user using the nuts provided.
- 2) Attach a protective cover in the case the sensor body is installed horizontally or facing downward. Insert the protective cover from the leading end of the sensor body and fasten it in position with the screws on the sensor body (M22 x 1.5).
- 3) Attach the head (needle) to the shaft on the leading end of the sensor body and fasten it in position with the head mounting screws. Be careful not to apply excessive force to the shaft at this time.

### 2. Signal setting procedure (refer to P12-3)

- 1) Place the drill bit (or other tools) at the predetermined location.
- 2) Position the sensor at a height such that the needle passes the drill bit at a location about 5 mm away from the end of the drill bit and fasten it in position by turning the nut.
- 3) Insert the mounting adjustment pushing rod into the hose nipple and push all the way in. The needle stops at 30 degrees before the stroke end\*.
- 4) While in this state, turn the sensor body so that the stroke end side of the needle contacts the drill bit, raise it up until the needle contacts the drill bit, and then fasten it in position with the nut.

**\*Note: Procedure when not using the mounting adjustment pushing rod:**  
When the air line has been connected and air pressure is applied, the needle stops at the stroke end position. In the case of clockwise rotation as shown in the drawing on P12-3 turn the sensor body so that the needle is located roughly 30 degrees to the right of the drill bit (refer to the dimension conversion chart), raise it up until the needle contacts the drillbit, and then fasten it in position with the nut. Supply with air for confirmation of the Stroke end signal and the Judgmentment signal.

### 3. Connection of the air line

- 1) Pass the air hose clamp over the air hose in advance.
- 2) Securely insert the air hose into the hose nipple on the back of the sensor body.
- 3) Fasten the air hose clamp at the base of the air hose nipple by turning the screw.

**Note1:** Use dry air at a pressure of 0.4 to 0.5Mpa.

**Note2:** Since the contact force of the needle when it contacts the drill bit is the sum of the inertial force resulting from rotation added to the spring pressure of the sensor (0.1N for a needle length of 100mm), reduce the speed with a speed controller as necessary to eliminate the risk of damaging the drill bit.

### 4. Cautions for plumbing

- 1) Use dry air.
- 2) In the case that the sensor is located a distance from devices such as air filters, dryers, or separators, the air inside the hose can get wet by temperature change due to coolant.
- 3) When the air supply is located higher than sensor, at least some part of the hose is set lower than the sensor to stores liquid. (The dew condensation may occur even using dry air)

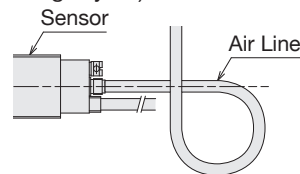

- 4) Coolant may enter into the sensor through the piping connection part. Do not use the part which has been repeatedly inserted and extracted.

### 5. Connection of the cable

- 1) Install the connection unit inside the distribution panel.
- 2) Connect the cable by referring to the circuit drawing on P12-2.
- 3) Since the sensor elements may be damaged if current beyond the rated current is allowed to flow through the sensor as a result of induction of noise or surge, run the cable at an adequate distance from power lines and other noise sources.
- 4) Do not pull on the cable sheath or core wires with excessive force (30N or more). In addition, clamp the cable at suitable locations.
- 5) The bending radius of the cable should be R7 or larger.
- 6) Be careful not to damage the cable during wiring. Damage to the cable may impair water resistance.
- 7) Do not connect the cable at the place where coolant may splash on the cable.

## Precautions

- 1) Use a cable protective wire braid when there is the risk of the cable being damaged by cuttings. Furthermore, check bends in the cable to make sure that the cable has not been damaged by cutting due to the formation of gaps between the braid wires at those locations. Use clamps at intermediate locations to ensure that excessive force and weight are not applied near the end of the cable.
- 2) Although the protective structure is IP67, add a separate protective cover when problems occur in movement of the needle due to the particular conditions of use (such as the orientation at which the sensor is installed or the presence of cuttings).
- 3) The drain port on the bottom of the sensor body is plugged with a screw. Drain water as necessary by removing the screw and then returning the screw to its original position when finished. Please consult us when it is necessary to change the location of the drain port due to the mounting position of the sensor.
- 4) Changing the head (needle)  
The head is fastened to the rotating shaft and fastened in position with a mounting screw. When tightening, be careful not to apply excessive force to the inside of the shaft.
- 5) Since driving by an air cylinder is employed, be careful so that the sensor does not suddenly begin to operate when the power and air supply are turned on.

## Release Notes

1. The performance values in the catalog are according to the company's conditions (room temperature, normal humidity, atmospheric pressure). When performing evaluation with the actual device, please check under the actual operating conditions.
2. Each rating and performance value of the catalog are that of the independent test, and do not guarantee the simultaneous complex conditions.
3. Please set the program of the machinery and equipment so as to stop within the stroke range of the sensor.
4. Depending on the surrounding environment and mounting position and direction, chips and coolant may intrude in the cover of the tool setter or touch probe or around the rubber boots, causing it to be adhered or fixed. As these may disturb the operation and cause the signal failure or malfunction, be sure to perform sufficient pre-evaluation under the real environment before the actual use.

## Mounting

1. Do not apply a shock such as by dropping it.
2. It should be mounted by firmly fixing to a rigid table or bracket where there is no chatter vibration.
3. Mounting, removal and maintenance of the sensor should be performed upon turning the power OFF.
4. Do not apply a force in a direction other than the sliding direction of the contact or collide objects. Scratch on the detection surface and deformation of the shaft may cause problems.
5. Please keep in mind that forcefully rotating the contact may cause internal damage.
6. Note that straightly pressing the detector, rapidly sliding and relieving it to the side and rapidly returning it by recoil may damage the bearings and internal contacts (when contacts are normally closed).
7. Note that pushing it in with a fingertip and returning at once (snap) may also damage the internal contacts.

## Contact Life Time

1. The contact ratings are DC5V - DC24V, steady current of 10 mA or less and rush current of 20 mA or less. Excessive load to the contact may cause the contact to deteriorate.
2. Depending on the type of load, there may be a great difference between the steady current and inrush current or the steady voltage and counter electromotive voltage. The higher the inrush current in closed circuit or counter electromotive voltage in open circuit, the greater the consumption of contacts and amount of transfer, which may increase the contacts to be fused, relocated and deteriorated.  
In order to avoid the effect of "1" & "2", please perform the following measures.
  - When there is excessive current to the contact, use the contact protection circuit (built-in or external I/F unit).
  - Do not bundle the wiring of the sensor with the power supply line of the power system.
  - Make sure that the ground resistance of the control system ground line does not increase.
  - Make sure that there is a margin to the power capacity of the control system power supply so that there will be no load fluctuation.
3. When switching the contact, chattering or bouncing (a phenomenon in which the signal is repeatedly intermittent) may occur which may contribute to the malfunction of the electronic circuit. In order to avoid this effect, please perform the following measures.
  - Detect it by the first signal switch.
  - Add a chattering prevention circuit (software timer interrupt, one-shot multi-vibrator, etc.).
  - Operating speed slower than 10 mm/min is not recommended. (50 - 200 mm / min when high-precision is required).
  - Increase the push-in amount after the signal is switched.
  - If the sensor is moved or vibration or impact is applied, it is to be energized only during measurement.
  - Vibration and impact that occur when the sensor is moved are to be mitigated by a shock absorber speed controller, etc.

## Wiring

1. Be sure to turn the power OFF when wiring.
2. Be sure to perform correct wiring upon checking the terminal name and polarity. Faulty wiring may cause internal component failure.
3. If the wiring of the sensor is performed in the same pipe or duct with the high-voltage line or power line, malfunction or damage by induction may occur. Please make sure to use separate wiring or piping.
4. When attaching the connector, make sure that the protection ring has been tightened firmly.

## Maintenance Checkup

### 1. Routine inspection

In order for the sensor to be used for a long period of time, be sure to regularly perform the following checks.

- Deviation of the mounting position, loosening and distortion
- Loosening of wiring and connection, poor contact and disconnection
- Adhesion and deposition of metal dust, etc.
- Abnormality in operating temperature conditions and environmental conditions
- Abnormal blinking for products with LED lamp

### 2. Disassembly and Repair: Do not disassemble and repair.

Not only will the performance be unsatisfactory, it may cause damage, electric shock and burn. The warranty will be void if you have disassembled and repaired the product on your own.

## Precautions for Sensor Connecting

Always make sure to turn off the power before installing or removing sensors.

This is to prevent damage to the device caused by improper wiring or short-circuits of output lines.

#### ● Photo MOS output type

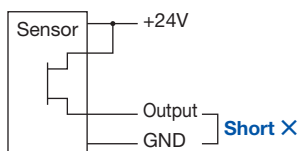

#### ● NPN transistor output type

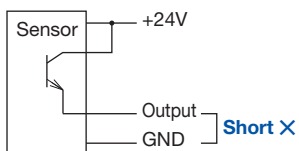

#### ■ Improper connections

##### NPN output sensor

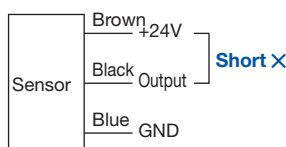

##### PNP output sensor

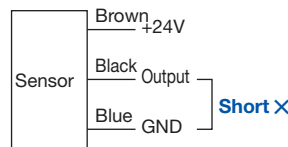

##### NPN output sensor

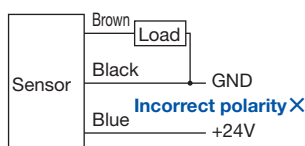

##### PNP output sensor

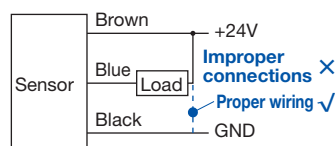

Application of an excessive voltage or application of an alternating current power supply (AC 24V or higher) to sensors using a direct current power supply has the risk of damaging the sensor.

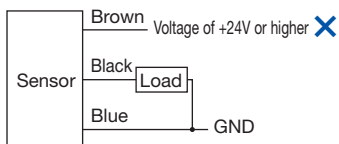
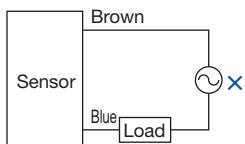

Either ground the sensor with a switching power supply in close proximity to the sensor or ground through a capacitor (approx. 0.1-0.47 $\mu$ F) for the purpose of lowering the impedance of the frame in order to increase resistance to entrance of induction noise by servo drivers or similar devices.

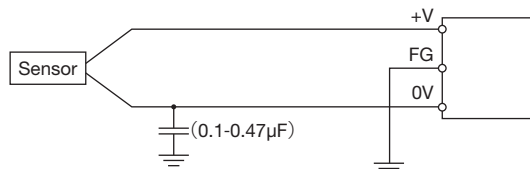

Alternatively, attach a ferrite core to the sensor cable.

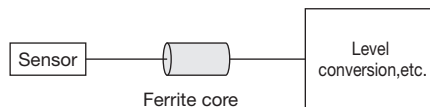

Application of an excessive voltage or application of an alternating current power supply (AC 24V or higher) to sensors using a direct current power supply has the risk of damaging the sensor.

Either ground the sensor with a switching power supply in close proximity to the sensor or ground through a capacitor (approx. 0.1-0.47 $\mu$ F) for the purpose of lowering the impedance of the frame in order to increase resistance to entrance of induction noise by servo drivers or similar devices.



## Cabtyre cable

Cabtyre cables are used as robot cables without any safety compromise since the working voltage and current are low, though cabtyre cables are not applicable to UL, CSA, EN or other safety standards.

### Specification

Conductor material	Copper-tin alloy, tight winding
Conductor resistance	1Ω/m (per 1 core)
Sheath material	Non-migrating styrene, oil-resistant, alkaline-resistant
Minimum bending radius	7mm
Sheath color	Black

### Cross-section area / weight (including sheath / 1m)

φ	Core	AWG	Area (mm <sup>2</sup> )	Weight (g)
φ3.7	4 core	AWG 30	(0.06mm <sup>2</sup> )	16g
φ4	5 core	AWG 28	(0.096mm <sup>2</sup> )	21g
φ4.8	6 core	AWG 28	(0.08mm <sup>2</sup> )	27g
φ5	2 core	AWG 30	(0.05mm <sup>2</sup> )	26g
φ5	4 core	AWG 30	(0.063mm <sup>2</sup> )	28g
φ5.5	5 core	AWG 30	(0.05mm <sup>2</sup> )	33g
φ5.5	6 core	AWG 30	(0.05mm <sup>2</sup> )	33g
φ7.2	14 core	AWG 26	(0.15mm <sup>2</sup> )	34g

### Precautions

- Do not pull or twist the cable with excessive force. (Max.30N (3kgf)). The bending radius of the cable should be R7 or larger.
- If you want to extend the cord on site, please make the distance as short as possible as it will otherwise be susceptible to the increase in the residual voltage and waveform distortion and induction due to the influence of the line resistance and line-to-line capacity. In addition, please use the cab tire cord with the cross-sectional area of 0.2 mm<sup>2</sup> or more.
- As the wiring of the high-voltage line or power line with the switch will cause malfunction by induction if it is done in the same pipe or duct, please make sure that different routes are used.
- Cabtyre cables are used as robot cables without any safety compromise since the working voltage and current are low, though cabtyre cables are not applicable to UL, CSA, EN or other safety standards.
- If waterproofing is required, please mold the terminal so that there will be no exposed portion.
- Use wire braid or protective tube when using under harsh environment such as where there are scattering of cutting chips.

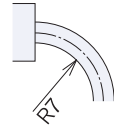

## Confirmation of Sensor Operation

- Connect the sensor in the manner shown in the diagram below.
- Limit the LED forward current to about 10mA by inserting a resistor.
- Resistance value = (power supply voltage - LED forward voltage) ÷ current = (24-2) ÷ 0.01 = 2KΩ. The LED forward voltage is about 2V.
- The resistor may be installed on the DC 24V or 0V side.
- The LED glows when the circuit is closed. Sensor operation is normal.
- In case of using a sequencer, a resistor is not required if the outflow current of the sequencer is about 7mA.
- Operation might not be properly confirmed using a digital test (multi-meter).

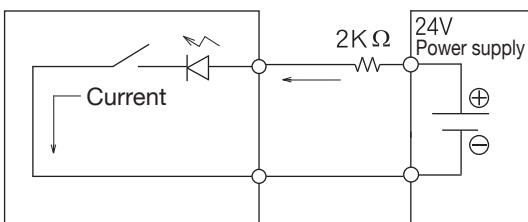

### Effect on accuracy due to electrical delay

- If there is a difference in the sampling times of the sensor signal and positioning data, large variations occur in repetitive accuracy when the measuring speed is increased.

### Connecting to a load

- Do not attempt to drive an inductive load directly with these sensors. Direct driving can damage the switching parts and semiconductors of the internal circuitry.
- In case of driving an inductive load, connect a surge absorber in parallel with the load, and connect an external load such as a relay or transistor allowing an adequate flow of current for load driving.

### In case of using a sensor with LED

- The LED can be damaged if the sensor is connected directly to the power supply (DC 24V). In case of using a sequencer, a resistor is not required if the outflow current of the sequencer is about 7mA.

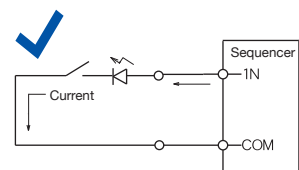
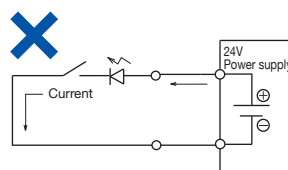



# Cable Options

## Cable Options

The following cable related options are available

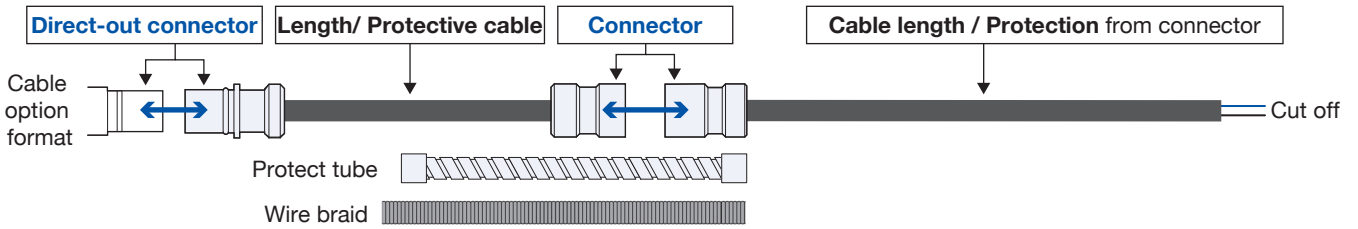

## Direct-out Connector

Product name	Cable	Protective structure	Dimension	Pullout strength
DC6	6cores $\phi 5.5$	IP67		With bayonet plug

## Connector

Product name	Cable	Protective structure	Dimension	Pullout strength
CC2	2cores	IP67		With bayonet plug
CC4	4cores			
CC5	5cores			
CC6	6cores $\phi 5.5$			

Caution : Do not pull the cable when you remove the connector. Push the connector firmly until it tightly fits with O-ring.

## Cable Protection (Protective structure, refer to P14-5)

### Protect tube

Used mainly in machining environment. (Protection from cuttings)  
Prevent damages to cables caused by heavy load falling on.

Dimension : outer diameter  $\phi 9$   
Minimum bending radius : 25mm

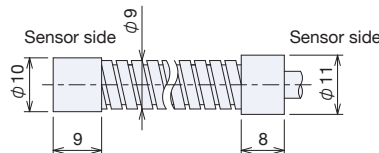

### Precautions

- 1) Sensor side is screwed in and metal ring is attached to machine side.
- 2) Because protect tube is not flexible, clamp it to fix so as not to apply excessive force to the sensor.
- 3) When binding it up and clamp with other cables, make sure not to apply excessive force to the attachment end.
- 4) The protect tube doesn't have water-resistant feature.

### Wire braid for cable protection

Material : Steel, clockwise tight winding  
Minimum bending radius : 7mm

Sensor side is fastened with screws and machine side is simply cut.  
When extension is needed, use threaded connection tube.

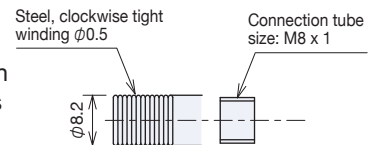

### Precautions

- 1) Since gaps are formed at bending section (especially at the attachment end) of the wire braid, make sure the intrusion of cuttings does not damage the cable inside.
- 2) Be careful not to damage the cable sheath as a result of crushing it during clamping.
- 3) When binding it up and clamp with other cables, make sure not to apply excessive force to the attachment end.
- 4) Fabricate the braided wire a little shorter than the cable length, since it extends with its own weight.

# Electrical specification Options for output specification

## I/F unit for contact type switch



### Specification

Product name	CL-1F	
Power supply voltage	DC24V ±10% (ripple 5% or less)	
Power consumption	15mA	
Input	One contact signal	
Output method	Photo Mos relay	
Diagram		
Output level	No-voltage floating output	
Output capacity	AC/DC200V 100mA	
Operating time	Delay	500μs (Representing value)
	Spread	10-20μs
Operating temperature range	0°C-50°C	

### Character

#### 1) Protection for the dry contacts from inrush current

The interface unit is not needed, when using the switches under the contact rating.

The contact point is unaffected by load current and protected since the I/O circuits for the contact current of the touch switch are separated.

#### 2) Increase the output current

Enable to drive a relay or similar devices directly.

When driving a relay by this unit, the repetitive accuracy would be lowered due to delay of the relay.

#### 3) Level conversion unit

Level conversion (normally close to normally open, normally open to normally close)

### Precautions for use I/F unit

- Do not connect the load exceeding the output rating specified for each model. Since the switching parts and interface elements may be damaged due to the flow of current in excess of the rating caused by noise or surge induction, place the switch at an adequate distance from any power lines or other sources of noise.
- Connect one switch to one I/F unit.
- Select the installation location of I/F unit so that the cable length between the switch and the I/F unit should not exceed 20m .
- Since the I/F unit is not waterproof, protect it from moisture such as water and oil.
- In case of using Normally-open type switch with a LED indicator, I/F unit can be used only when the LED is normally OFF and turns ON in operation. Similarly, for Normally-Close type switch, the unit can be used only when the LED is normally ON and turns OFF in operation.
- This I/F unit is especially designed for the METROL switches, do not use this I/F unit with the switch from other manufacturers.

### Outer dimension

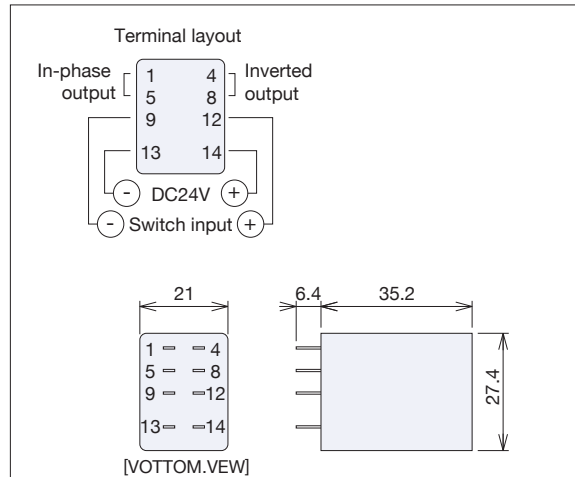

No terminal block is provided.

Refer to the following.

Panasonic: HC2-SFD-S

Omron: PYF-08A

### Connection diagram (Plural switches)

When connecting plural switches to one plug-in type interface unit, refer to the diagram below.

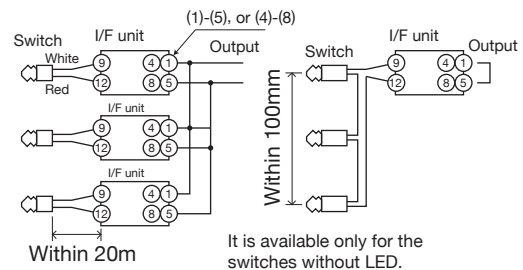

- Make sure no noise and inductive source.
- Overall length of the sensor side cables should not exceed 100mm.

### Connecting diagram with electrical load

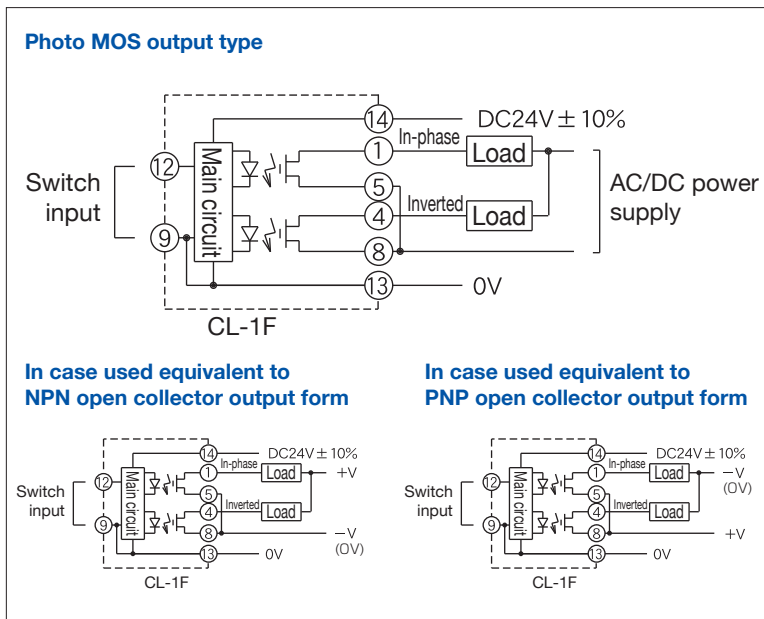

# TECHNICAL GUIDE

## ■ Electrical specifications

**Terminology - Definitions and Explanations -** ... P14-2

**Switch series and parallel connection methods** ... P14-2

· Direct current 2-Line Type

· Direct current 3-Line Type

**Conditions of use** ..... P14-3

· Use with AC 100V-200V

· Connecting to a load

· In the case of using a switch with LED

**Confirmation of switch operation** ..... P14-3

· Dry contact type

· Contact-less type

· Confirming operation by using resistance

· Confirming operation by using voltage

---

## ■ Mechanical specification

**Terminology - Definitions and Explanations -** ... P14-4

**Protective structure** ..... P14-5

· IP code

· Waterproofing (Coolant)

· Dustproofing

· Protective cover

---

## ■ Setting methods

**Switch installation and signal setting methods** ... P14-6

**Preliminary installation and off-line settings** ..... P14-7

## ■ Common sense of measurement

**Basics of measurement** ..... P14-8

· Accuracy

· Abbe theory

· Temperature

· Shape of contacting part and contact force

· Timing of measurement

· Contacting point

## Electrical specifications Terminology - Definitions and Explanations -

### Output mode

This refers to the type of signal output from switching part. There are two types of signals as indicated below.

- (1) Normally open NO
- (2) Normally close NC

#### How to select

##### Characteristics of normally open (NO) type

- All types have pretravel (the distance it needs to be pressed to output the signals), and in the case of dry contact types, there is no occurrence of chattering since the switching part is normally open.
- NPN open collector output types can be easily connected to programmable controllers (PLC), sequencers and CNC.

##### Characteristics of normally close (NC) type

- Types with and without pretravel are available. In case of dry contact types, since the switching part is normally closed, chattering may occur due to vibrations (mainly in cases of low contact force).
- Normally close circuits are failsafe (any input errors are notified immediately). The use of this interlock system makes it possible to diagnose malfunctions such as cable disconnections and signal transmission problems.

##### Inversion (Level Conversion) method: NO→NC,NC→NO Electrical:

- By connecting an I/F unit to either the NO type or NC type, the output of the I/F unit can be inverted (NO→NC, NC→NO).
- NC types converted from an NO type by an I/F unit are no longer failsafe.

##### Mechanical:

- Inversion is possible depending on the installation method.
- By initially pushing in the free position.
- Inverted by means of a lever.

### Open collector

The output terminal of this transistor circuit is the collector of the transistor (see diagram below).

#### NPN transistor output (Open collector)

Since circuits using an NPN transistor absorb the load current (in the manner of a sink), the load is connected between a power supply having a potential higher than ground and the collector.

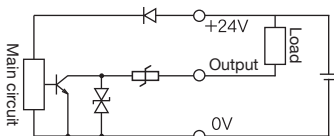

- NPN transistors are commonly used transistor. Connections can be directly made to a programmable controller or counter.
- These are popular in Japan and the US in the form that absorbs current (sink type).

#### PNP transistor output (Open collector)

Since circuits using a PNP transistor discharge the load current (in the manner of a source), the load is connected between the circuit ground and the collector.

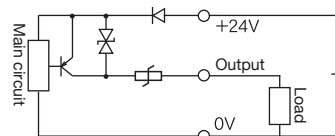

- These are incorporated primarily in devices exported to overseas destinations such as Europe.
- These are in the form that discharges current (source type).

### Types of loads

#### Resistance loads (Expressed in the output rating)

- These mainly refer to loads in the form of resistors.
- These loads make it difficult for large current to flow when the circuit is switched on and off, and the current that flows to the circuit can essentially be calculated using the following equation:  
Current value = voltage value ÷ resistance value

#### Inductive loads

- These primarily refer to relay coils, motors and solenoids.
- Load can be used only when the driving current of these loads is within the switch contact rating. When the switch is turned off, counter electromotive force is generated and will require a diode or surge absorbing element to be connected in parallel to absorb this.

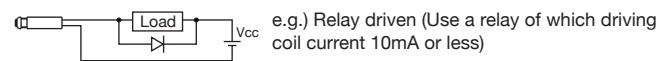

## Switch series and parallel connection methods

### Direct current 2-line type

#### Series connection (AND)

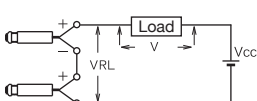

#### Wiring precautions:

When the connected switch is on, the load voltage  $V_{RL}$  is defined as  $V_{RL} = V_{cc} - n \times x$  (V), caution is required with respect to defective load operation.

$V_{cc}$ : Power supply voltage 24V (max)  
n: No. of switches  
3(V): Switch drive voltage  
V:  $V_{cc} - V_{RL}$

#### Parallel connection (OR)

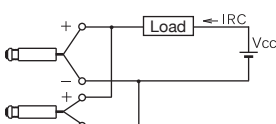

When the connected switch is off, the leakage current IRC flowing to the load is defined as  $IRC = n \times 0.8$  (mA), caution is required with respect to defective load return.

There is no limit in the number that can be connected in the case of contact switch (no LED or built-in interface unit)

### Direct current 3-line type

#### Series connection (AND)

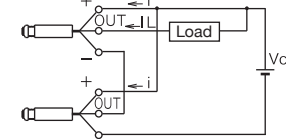

#### Wiring precautions:

The number of connected switches must be within the range that satisfies the following relationship:

$IL + (n-1) X_i \leq$  Upper limit of switch control output\*  
10mA (max) in case of non-contact switches.

#### Parallel connection (OR)

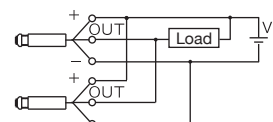

In case of using an AND/OR connection, since there may be cases in which this type of connection cannot be used due to erroneous signals or leakage current, please confirm the absence of such problems before using.

## Conditions of use

Please use dry contact types at a voltage and current within the contact rating.

### Use with AC 100V-200V

- These switches cannot be directly controlled with AC 100-200V.
- Please refer the diagrams below in the case of desiring to operate a solenoid valve or AC 100V relay with the switch signal in the absence of a DC power supply within the device.

A DC power supply (DC 24V, approx. 0.2 A) is provided and the switch and interface unit (CL-1F) are used to operate the valve and relay.

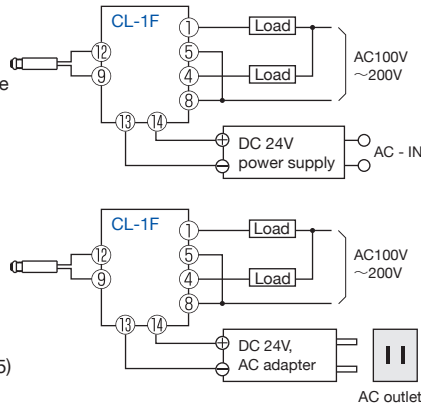

Interface unit (Refer to P13-5)

### Use with micro load

Use the switch within the range of DC 24 V, 0.2 mA to 10 mA (max.)

## Confirmation of switch operation

### Dry contact type

- Connect the switch in the manner shown in the diagram below.
- Limit the LED forward current to about 10mA by inserting a resistor.
- Resistance value = (power supply voltage - LED forward voltage) ÷ current = (24-2) ÷ 0.01 = 2KΩ. The LED forward voltage is about 2V.
- The resistor may be installed on the DC 24V or 0V side.
- The LED glows when the circuit is closed. Switch operation is normal.
- In case of using a sequencer, a resistor is not required if the outflow current of the sequencer is about 7mA.
- Operation might not be properly confirmed using a digital test (multi-meter)

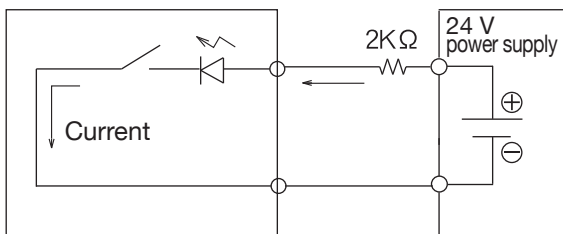

### Confirming operation by using resistance

- Set the tester to a resistance range of x 10, and connect the minus lead of the tester to the switch output (brown), and connect the plus lead of the tester to the switch 0V (blue).
- The deflection of the tester needle indicates around 0Ω when the switch plunger is pushed in and roughly infinity (∞) when switch tip is returned.
- For switches with LED, note that the tester may not swing.

### Effect on accuracy due to electrical delay

- If there is a difference in the sampling times of the switch signal and positioning data, large variations occur in repetitive accuracy when the measuring speed is increased.

### Connecting to a load

- Do not attempt to drive an inductive load directly with these switches. Direct driving can damage the switching parts and semiconductors of the internal circuitry.
- In case of driving an inductive load, connect a surge absorber in parallel with the load, and connect an external load such as a relay or transistor allowing an adequate flow of current for load driving.

### In case of using a switch with LED

- The LED can be damaged if the switch is connected directly to the power supply (DC 24V). In case of using a sequencer, a resistor is not required if the outflow current of the sequencer is about 7mA.

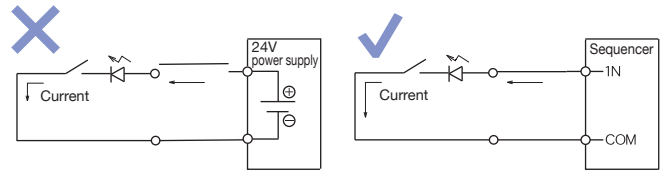

### Non-contact type

- Connect the switch in the manner shown in the diagram below.
- Please note that output circuit will be damaged by over current, when switch output under NPN output form is directly connected to +24V or when switch output under PNP output form is directly connected to 0V.
- Please insert resistor with resistance around 3kΩ so that a current of about 10mA will flow (1) between +24V and output in case of NPN output type, (2) between 0V and output in case of PNP output type, in the output circuit.
- In case of using a sequencer, a resistor is not required when the outflow current of the sequencer is about 7mA.

#### NPN Output

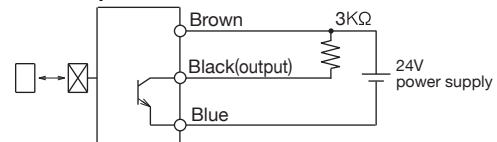

#### PNP Output

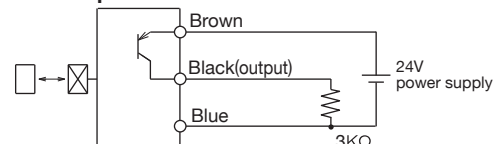

### Confirming operation by using voltage

- Set the tester to a voltage range of 50V and measure the voltage between the switch output (black) and 0V (blue).
- For NPN output type, when the tip of the switch is pressed, the indicator of the tester changes from 24V down close to 0V.
- For PNP output type, when the tip of the switch is pressed, the indicator of the tester changes from 0V up close to 24V.

## Mechanical specification Terminology - Definitions and Explanations -

### Signal point (Operating point)

#### Position where a signal is generated

- This is normally indicated with pretravel.
- Since it is easier to make a judgment on the signal point based on the contacting part position and this does not vary according to the conditions of use or type of contact used, position and accuracy can be clearly indicated.

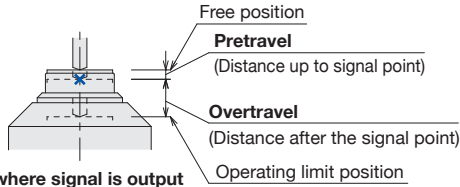

### Pretravel PT (Distance up to signal point)

#### Amount of movement from free position to signal point

- There is always pretravel in case of normally open (NO) sensors.
- The normally closed (NC) sensors are available with and without pretravel.

### Overtravel OT (Movement after signal point)

#### Amount of movement from signal point to operating limit position

The greater the amount of overtravel, the less chance of colliding and causing a malfunction.

### Stroke TT (Overall movement : Total travel)

#### Amount of movement from free position to operating limit position

This is the sum of pretravel and overtravel.

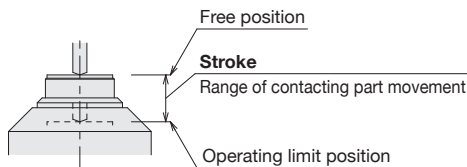

### Contact force

#### Amount of force required for the contact to move from free position to signal point (Units : N)

- The contact force will increase in accordance with the pushing amount of the contact. (depending on the spring constant)
- Contact force is set in the specified mounting orientation. This mounting orientation is the vertical orientation unless otherwise specified.
- When using a vertical mounting type in horizontal orientation: Contact force increases by the weight of the movable unit. This requires caution particularly in case of large-diameter contacts and low levels of contact.
- When using the horizontal mounting type vertically, the contact force decreases according to the weight of the movable part. It may cause the zero reset error.
- In case of touch probes, contact force can be reduced according to stylus length.
- Please be aware to the stiffness of the bracket for the large contact force type.



### Movement differential MD

#### Amount of movement until signal is inverted after returning from signal point

- This region is an undetected area. Movement differential occurs for any types of electrical switches, including limit switches, micro switches, proximity sensors and optical sensors.
- Since the signal is not inverted unless the contacting surface returns by greater than the amount of the movement differential in case of using in such a manner that the contacting surface returns immediately after operating, thickness less than the movement differential as shown in the diagram cannot be discriminated. Therefore pretravel greater than or equal to the movement differential is required in case of non-contact devices.

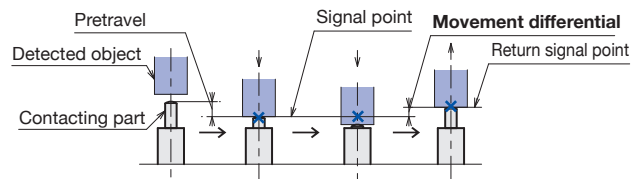

### Hysteresis (Return difference)

#### This refers to a difference in the operating point when the contacting part has returned after being pushed beyond the operating position.

- In addition to the sensor itself, the amount of deflection of a retaining portion (support column) may be added due to the contact force.
- Please be aware to the stiffness of the bracket for the large contact force type.
- \* Hysteresis is different from movement differential

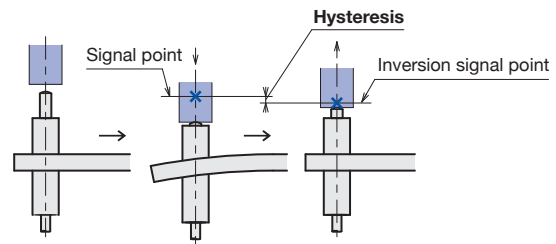

### Repetitive accuracy (Repeatability)

The detected object is pressed from the vertical direction towards the contacting part of the sensor. The difference between the maximum value and minimum value obtained from the variation in the signal point (dimensions) when pushed in 30 times is represented with the range (R) (defined by METROL).

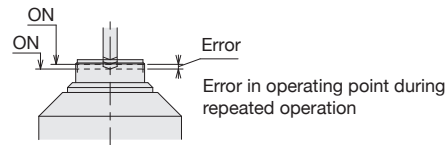

### Temperature drift (Temperature characteristics)

#### Movement of signal set position by ambient temperature changes

- This indicates the amount of fluctuation in the operating position caused by fluctuations in parameters of an electronic component corresponding to a change in the working temperature.
- It is necessary to additionally take physical thermal expansion of the attachment into consideration .

### Contacting part

#### This refers to the portion of the sensor that contacts a detected object.

- Contacting part is also referred to as a probe.



## Protective Structure

### IP Code

Protective structure refers to the level of dust resistance and moisture resistance.

All products in this catalog are indicated with characteristic numbers in the form of an IP code based on IEC 529:1989 (Degrees of Protection Provided by Enclosures).

(International Protection) → IP 6 7

First characteristic number (0-6) : Penetration of extraneous solid objects.

Second characteristic number (0-8) : Penetration of moisture accompanying detrimental effects.

Number	Intrusion of Extraneous Solid Objects	Intrusion of Moisture Accompanying Detrimental Effects
0	Unprotected	Unprotected
1	Protected against extraneous solid objects 50mm or more in diameter	Protected against vertically dripping water
2	Protected against extraneous solid objects 12.5mm or more in diameter	Protected against dripping water at an angle of within 15 degrees of vertical
3	Protected against extraneous solid objects 2.5mm or more in diameter	Protected against spraying water
4	Protected against extraneous solid objects 1.0mm or more in diameter	Protected against splashing water
5	Dustproof: No intrusion of an amount of dust that impairs enclosure operation	Protected against pressurized water from any direction
6	Dust-resistant: No intrusion of dust	Protected against jetted pressurized water from any direction (high pressure)
7	-	No intrusion of water in an amount that causes detrimental effects even with respect to temporary penetration.
8	-	No intrusion of water in an amount that causes detrimental effects when continuously immersed in water under strict conditions determined by relevant authorities

### Waterproofing(coolant)

The water-resistant performance of this standard refers to water. However, the following measures are adopted since coolant and cutting oil are commonly used for machine tools.

- Rubber materials used in some products (boots, O-rings) provide protection against water-soluble coolants and alkaline liquids.
- When covering of cables are broken, liquids penetrates into the cable due to the capillarity action, causing short circuits and contact failure. Attach protective blades for cables when cables might be damaged due to chips. (Refer to P13-4).
- Install rubber boot and O-rings after disassembly so that sealing can be kept. Whenever they are damaged, replace them by a new one. Apply seal locking agent to the screw threads.
- When making a connection to extend the cable, use a molding so that there are no exposed portions when the end of the cable is connected to a terminal.
- Please note that adhesive and sealants may be eroded by coolant.

### Dustproofing

Air blowing is effective for removing dust, cuttings or coolant adhered to the contacting surface depending on the type of adhered debris. However, the following measures are required for highly viscous substances that can not be removed by blowing with air.

- Provide protective covers (optional) if the rubber boot might be damaged due to chips.
- Provide automatic opening and closing covers (especially when operating without operators).
- If a protective cover is still insufficient, provide a separate protector against chips.
- Provide a separate cover if high pressure coolants or water stream hit the contact or boot protector.

### Protective covers

Protective cover are for preventing damage to rubber boots and impairment of water-resistance or dustproofing caused by metal fragments and other cutting.

Please select the shape of protective covers while considering the factors indicated below.

- Choose the shape of protective covers in consideration of mounting direction, the direction of coolant, air blower, and the gap.
- When there is no risk of damage to the rubber boots as in the case of plastic or wood cutting of grindings, it may be better to rinse off such debris with coolant or blow it off with blowing air, without attaching a protective cover.
- An extra cover is recommended to avoid direct hit by high-pressure coolant or heavy cuttings.

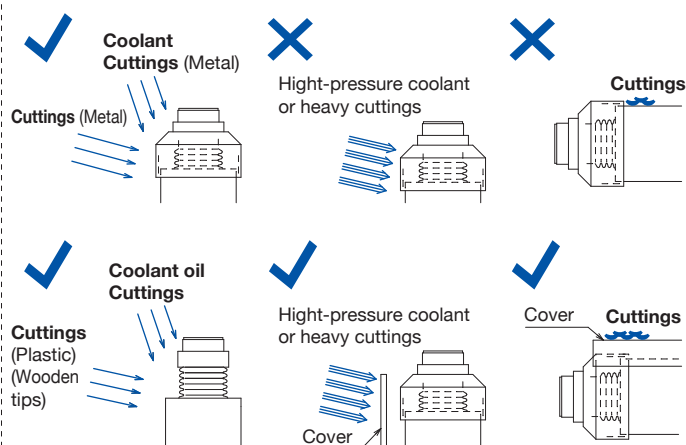



## Switch installation and signal setting methods

The methods used to install switches and set the signal operating points vary depending on the purpose in which the switch is to be used.

### 1. Classification according to purpose

#### 1) Setting the signal point as the origin or reference point.

There is no particular need to set an operating point if the signal output at the position where the contact switch is to be installed, is the origin or reference point.

The following points are selecting factors of the contact switches.

- High repetitive accuracy
- No influence by external environment (e.g. Drifts caused by power supply voltage, temperature, intensity of light, magnetic field, etc.)
- Small movement differential and hysteresis
- No restriction on the materials and shapes of detected objects.

As the switches with an amplifier magnify not only the accuracy but also the fluctuation and drifts, there are the cases where these switches are not suitable for use in such a harsh environment.

#### 2) Applications involving making a judgment of pass or failure using a defined position or dimension as a limiting criterion.

These applications require heightened setting accuracy of signal points. Generally, the following 2 types of setting errors are known.

- **Type 1 Errors**  
misjudging good products as defective ones.
  - **Type 2 Errors**  
misjudging defective products as good ones.
- ← It can be a cause of short time breakdown in the production line.

Trying not to commit the type 2 errors is important since the setting errors of the signal point, to some extent, are unavoidable. When the application only needs existence detection and doesn't require high position accuracy, there still is the same idea applying to the settings of pass/ fail border.

### 2. Important factors regarding installation methods and signal setting methods when accuracy is required

#### 1) Ease of making fine adjustments

- The direction of adjustment of the switch body should be coaxial.
- In case of split clamping, there should be no engagement or screw rattle in the semi-clamped state, and movement should be smooth.

#### 2) No occurrence of position shifting when locked

- The locking position should be near the core.
- There should be no application of thrust in the axial direction during locking.

#### 3) Adopting preliminary installation and off-line settings (Refer to P14-7)

### 3. Installation using a switch bracket and adjusting signal operating point

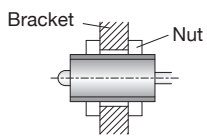
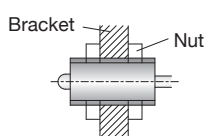
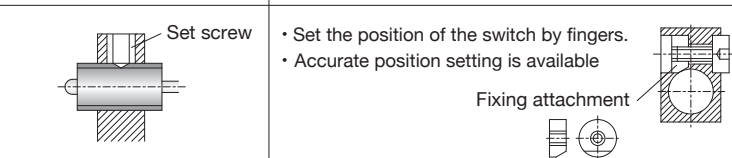
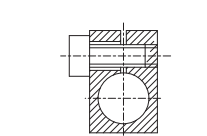
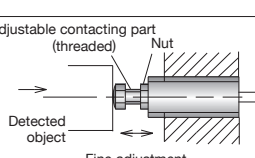
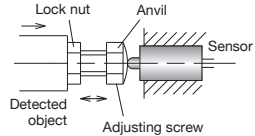
Installation and setting using a switch bracket	Signal setting methods and characteristics	Switch fixing methods
<b>A</b> Switch outline: <b>Threaded</b> Bracket: <b>Large clearance (straight hole)</b>	 <ul style="list-style-type: none"> <li>· Alternatively tighten the 2 nuts and set and fix the switch</li> <li>· Not suitable for accurate positioning.</li> <li>· Suitable for existence detection</li> </ul>	The switch is locked in. Position shifting occurs during setting. Note that the rigidity of commercially produced brackets.
<b>B</b> Switch outline: <b>Threaded</b> Bracket: <b>Tapped</b>	 <ul style="list-style-type: none"> <li>· Screw in and out the switch for position setting.</li> <li>· Accurate position setting is available (Fine thread is recommended)</li> <li>· Do not twist the cables</li> </ul>	The switch is locked in position with 1 or 2 nuts. Position shifting may occur during setting.
<b>C</b> Switch outline: <b>Non-threaded (h7)</b> Bracket: <b>Small clearance (H7)</b>	 <ul style="list-style-type: none"> <li>· Set the position of the switch by fingers.</li> <li>· Accurate position setting is available</li> </ul>	There is limitation for tightening strength. Malfunction may occur due to excessive force applied to the fastening part. When using a frame, there is less possibility of deformation.
<b>D</b> Switch outline: <b>Non-threaded (h7)</b> Bracket: <b>Small clearance (H7)</b> Split clamping	 <ul style="list-style-type: none"> <li>· Setting the position in the semi-clamped state.</li> <li>· <b>Most accurate setting is available.</b></li> </ul>	No occurrence of position shifting when fastening the switch.
<b>E</b> Setting by the <b>adjustable contacting part</b> (Refer to P2-7)	 <ul style="list-style-type: none"> <li>· No need for position setting. Suitable to inline adjustment.</li> <li>· Combinations with A-F are available.</li> </ul>	The switch is locked in the position with the nut.
<b>F</b> Setting by the anvil of detected objects such as moving tables. (Not available when the detected object is workpiece.)	 <ol style="list-style-type: none"> <li>1) Turn the threaded contacting part or anvil up to the signal point.</li> <li>2) Make a half-turn backward and fix it by the nut.</li> <li>3) Next, slightly loosen the nut and then fasten in the signal output position by turning the anvil when there is no play in the screw. Lock in position by tightening the nut.</li> </ol>	

## Benefit of preliminary installation and offline settings

1. Accuracy improvement of signal point (signal setting by using dial gauges or micrometers).
2. Save a great deal of time for setups and changeover of machines.  
(Improvement in availability ratio of the machine and cut-down of maintenance time.)
3. Reduction of on-line setups, adjustment, and assembly.
4. Cut down the Mean Time To Recovery. (MTTR)
5. As the repair work is simplified, skilled technician is not required. (No visit to customers, Cut down on maintenance cost)

## Preliminary installation and offline settings

### 1. Preliminary installation and setting for 1-signal type switches

- Preliminary adjustment of the signal point refers to installing the flange, bracket and other parts on the switch outside the machine and setting to the predetermined dimensions so as to eliminate or minimize adjustments within the machine.
- In case of contact switches, the signal is output at a fixed position from the switch body. Thus, if the installation reference surface is set in advance for the switch outside the machine, and the distance from the operating point is set to the predetermined dimensions indicated in the design, position adjustment is not required to be performed inside the machine.
- Unlike non-contact switches, contact switches are not affected by the surrounding environment, such as the material, shape or brightness of the detecting body or magnetic fields.  
(Refer to P14-6 for signal setting method)

#### Installation reference surface

Slit types of commercially available split clamping brackets are frequently produced for the purpose of powerfully tightening balls and so on, and caution is required since there are many that are not suitable for switch inching and adjustment. Additional machining is required in such cases.

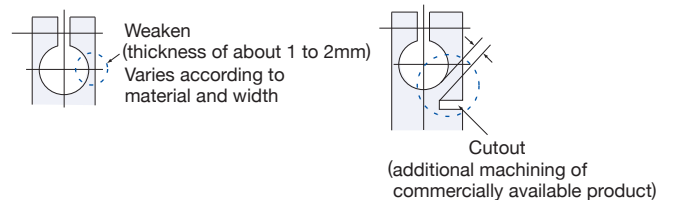

#### In case of using the switch with a non-threaded switch case.

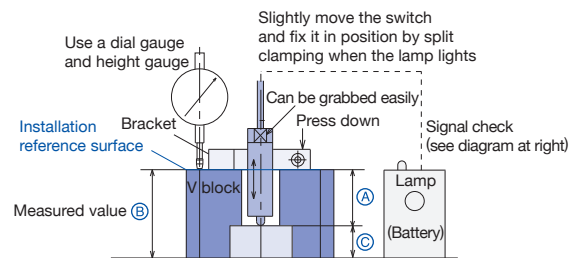
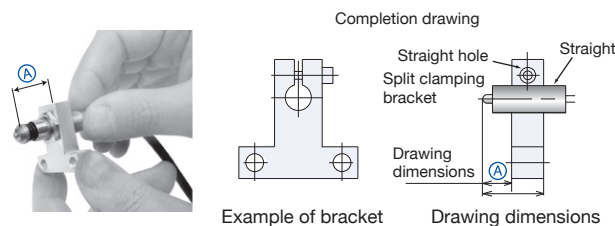

#### In case of using the switch with a threaded switch case.

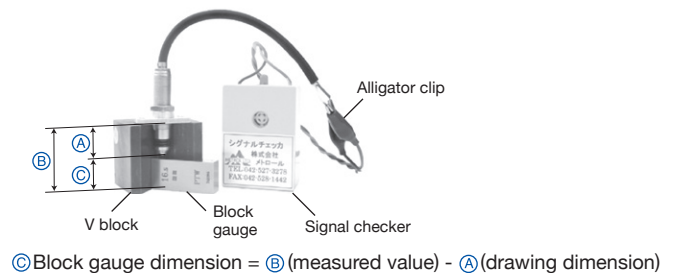
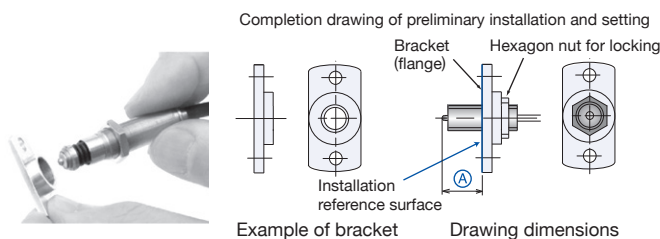

## Basics of measurement

Generally speaking, dimensional measuring instruments, having a built-in scale, not only convert values of displacement to electrical quantity or light intensity, but also amplify, calculate, and record the value. These instruments output signals as threshold values. The price for the instruments is relatively high because an amplifier is required.

On the other hand, METROL contact switches don't require the built-in scale, and output accurate signals as limit values from a built-in switching part.

Except off-line use, there are the cases, mostly in machines, where general instruments are only required to output signals as limit values. In that case, METROL contact switches can show a great cost-effectiveness replacing those expensive instruments. Since the basic knowledge of measurement is required to make full use of METROL contact switches, refer to the following for your information.

### 1. Accuracy

Accuracy consists of "Precision" and "Correctness".

The fluctuation range of numerical values obtained from multiple measurements is called "**Precision**", and the difference between the obtained values and true values is called "**Correctness**".

Fig.1

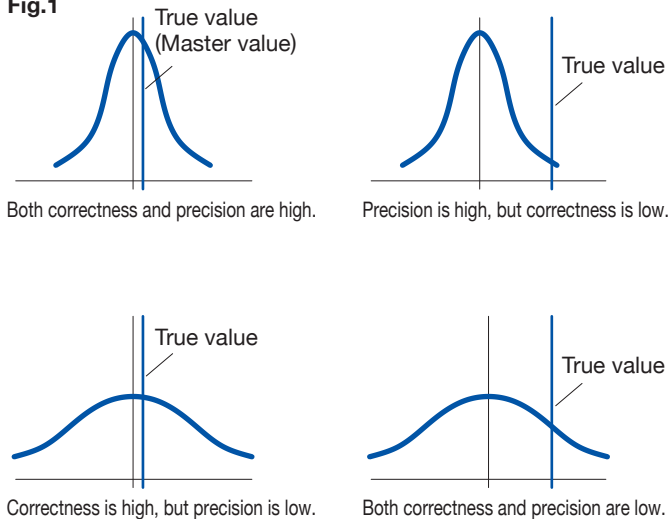

There is the practice of indicating "**Precision**" as "Average value", "Deviation value" or "Range" by taking operating point signals output from the measuring instruments such as digital micrometers or NC scales, etc. measuring displacement of detected objects

Fig.2

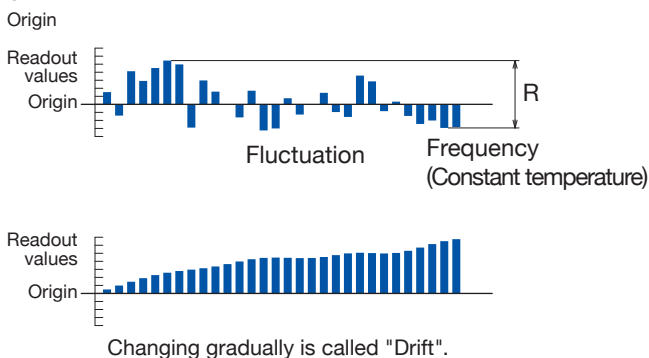

### 2. Abbe theory

**A detected object and a standard scale need to be arranged on the same axis to heighten measurement accuracy.**

That is known as Abbe theory. Close to our hand for example, this theory applies to micrometers but doesn't apply to slide calipers.

Fig.3

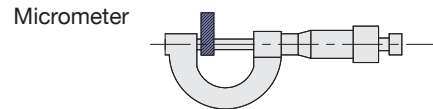
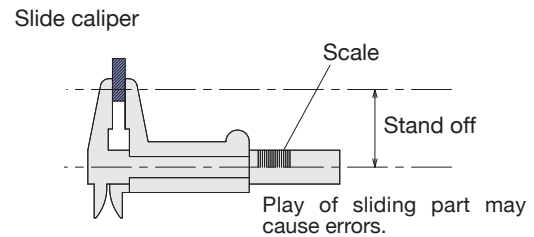

Fig.4



When using a switch, offset touch, as shown below, is not recommended. This can also apply to fine position setting methods. Offset touch is subjected to rattle of sliding part, loss of perpendicularity, and deflection of the holder.

Consequently, the way in which the highest accuracy can be obtained by using cylindrical type switch is to locate the plunger of the switch on the same axis as the measuring direction and slide the switch on the same axis for precise position setting.

Fig.5

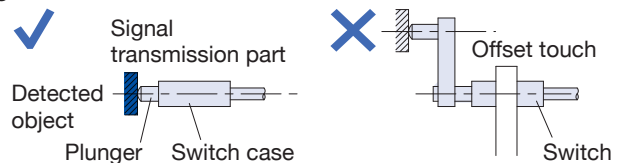

In addition, accidentally applying sideways tightening force to the plunger may cause errors. (e.g. Split clamping, Set screws)

Fig.6

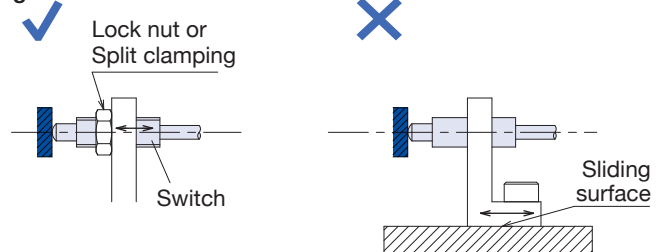

## 3. Temperature

**Instruments and workpiece are subjected to expansion and contraction according to temperature change.**

20°C is standard in industrial standard. The expansion and contraction cannot be clearly calculated under the condition of different materials and thermal capacities as well as changes over time. Consequently, the following points are important to minimize the risk of expansion and contraction of instruments or workpiece.

- 1) Keep the temperature constant.
- 2) Set the origin by using masterwork whenever a great temperature change occurs.
- 3) Select a switch that is least subject to temperature changes.

These attempts results in only minimum compensation required for use (for example, expansion of high-speed machining spindle).

In that case, a METROL tool setter for machining centers can compensate thermal expansion of high-speed spindle. Since there are cases where dimensions realistically affected by flexure (bimetal) greater than expansion and contraction, it may be more effective to bring countermeasure for the flexure.

Fig. 7

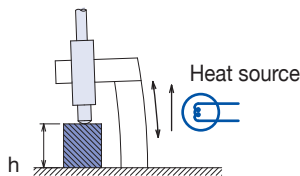

Keep it in mind that simple expansion and contraction of iron is 1  $\mu\text{m}$  by 10°C (Brass is 1.9  $\mu\text{m}$ , Aluminum is 2.8  $\mu\text{m}$ ). There are measures as heat sources such as external temperature, motor, shock absorber, cylinder, high-speed spindle, coolant, weld, cutting, and body heat, and their conduction and radiation are also taken into account. In addition, as constant numbers for elements of electrical parts vary by temperature change, contact-less type switches with an electrical circuit in term of amplifier inevitably has temperature drift. Refer to section 6, Fig. 8

## 4. Shape of contacting part and contact force

**These two measures are closely related to each other. And changing the two measures results in instrument errors. The following points are to be noticed.**

- When contacting detected surface, point contact is the best way to obtain the highest accuracy. But the smaller the dimension of contacting point becomes, the larger the contact force can be. That may cause deformation of either contacting part or detected surface. (This can be calculated by Hertz equation. But it doesn't make a big difference in reality).
- Point contact is subjected to plane roughness and friction.
- Large contacting surface may cause errors by deflection due to geometric deformation.
- Since excessive contact force may cause errors by flexure of switch holder, commercially produced less-rigid brackets can be used only for low contact force type switches.
- Flexure (Range of elastic deformation) can be a main factor of hysteresis and may generate drift.
- Deformation of switch holders can be caused not only due to excessive contact force but also by excessive force applied while fixing.
- The contacting force is defined mainly by spring force. But the frictional force of the plunger should be subtracted from the spring force. Absence of this idea may cause return errors.
- Since non-contact switches (Proximity switches and photoelectric switches) detect objects with the detecting surface and output average values calculated from dimension of the surface, the values are different from actual measurement values and actual dimensions. Installing contact type actuators marks up the total cost and causes loss of accuracy.

## 5. Timing of measurement

Measurement before processing is called **Pre-Process Measurement**.

(e.g. Measurement of unprocessed workpiece and parts dimension before assembly. Detecting process errors from previous operation. Upside-down detection of workpiece.)

Measurement during process is called **In-Process Measurement**.

(e.g. During grinding process, measure the work piece dimension and stop the process when the dimension comes in the allowance. Checking bending radius when the object bent.)

On-line measurement after process is called **Post-Process Measurement**.

(e.g. Eliminate defectives after process while giving feedback to previous process.)

## 6. Contacting point

**In case of contact measurement, accuracy varies according to how to make the detecting part contact with objects.**

### 1-point measurement method (Thickness measurement)

In Fig. 8 (a)(b), deformation and thermal displacement of the fixing part, retracting part cause errors.

In Fig. 8 (c), warpage of workpiece, dust and cuttings are error factors.

Fig. 8 Deflection, thermal displacement

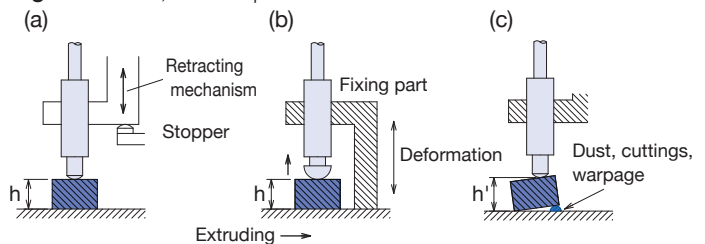

### 2-point measurement method

In Fig. 9 (a), making the stopper prop with base level prevent errors shown in (a)(b) in Fig. 8.

In Fig. 9 (b), errors can be prevented by comparative tolerance between the masterwork and the detected workpiece. Equivalent to step measurement.

In Fig. 9 (c), errors caused by dust or warpage can be prevented by holding the workpiece between 2 points. Plate spring hinge or bearing is used for the floating mechanism.

Fig. 9 (Errors may occur due to repeatability of the movement or temperature change.)

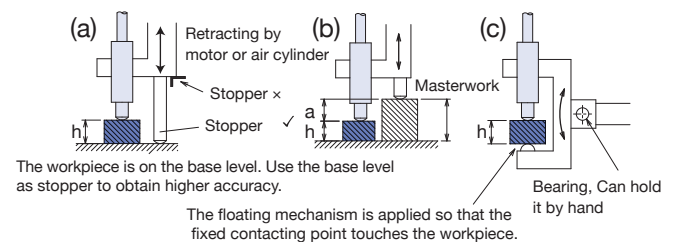

### 3-point measurement method

In Fig. 10 (a)(b)(c), though large diameter or sphere workpiece are measured as center-less, magnification ratio drops according to opening angle. This results in loss of accuracy.

Fig. 10

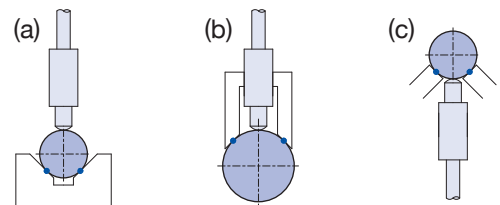

# Alphabetical Index

<b>B</b>		F4129AW	P7-6	P10SA	P3-10	STM62A	P5-10
BP060A	P5-16	F4129W	P7-6	P10SB	P3-10	STM82A	P5-10
BP4SWA	P5-14	F4130AW	P7-6	P10SHA	P3-16	STMB11A	P5-10
BP5MWA	P5-14	F4130W	P7-6	P10SHB	P3-16	STMB12A	P5-10
<b>C</b>		F4131AW	P7-6	P11DDB	P3-22	STP080DA	P5-4
CC2	P13-4	F4131W	P7-6	P11DMB	P3-22	STP080DB	P5-4
CC4	P13-4	F4132AW	P7-6	P11EDB	P3-22	STP080UA	P5-4
CC5	P13-4	F4132W	P7-6	P11EMB	P3-22	STP080UB	P5-4
CC6	P13-4	F4150AW	P7-6	P12DA	P3-10	STP100DA	P5-4
CL-1F	P7-4,P13-5	F4150W	P7-6	P12DB	P3-10	STP100DB	P5-4
CS065A	P4-3	F4161W	P7-6	P12DLB	P3-10	STP100UA	P5-4
CS067A	P4-3	F4161AW	P7-6	P21	P10-15	STP100UB	P5-4
CS067B	P4-3	<b>G</b>		PT5M1CB	P3-4	STS060PA	P5-4
CS087A	P4-3	GN-PT5M3A	P6-6	PT5M1WA	P3-4	STS060PB	P5-4
CSFN105A	P6-2	GN-PT5M3B	P6-6	PT5M1WB	P3-4	STS080PA	P5-4
CSFSN10A	P6-2	GN-PT5M3A-R	P6-6	PT5M3WA	P3-4	STS080PB	P5-4
CSH121A	P4-11	GN-PT5M3B-R	P6-6	PT5M3CB	P3-4	STS100PA	P5-4
CSH121B	P4-11	<b>H</b>		PT5M3WB	P3-4	STS100PB	P5-4
CSHP085A	P4-9	HT-BP060A	P6-4	PT5S1CB	P3-4	<b>T</b>	
CSHP085B	P4-9	HT-CS067A	P6-4	PT5S1WA	P3-4	T20-120	P10-11
CSJ055A	P4-3	HT-STM82A	P6-4	PT5S1WB	P3-4	T24E-120	P10-8
CSJS50A	P4-3	H4A-001	P11-3	PT5S3CB	P3-4	T24E-240	P10-9
CSK087A	P4-3	H4E	P11-5	PT5S3WA	P3-4	T24E-260	P10-10
CSK087B	P4-3	<b>K</b>		PT5S3WB	P3-4	T26K	P10-13
CSM105CA	P4-13	KS21PA	P5-4	PTP5M1CB	P3-4	TD1	P10-17
CSM105WA	P4-13	KS21PB	P5-4	PTP5M3CB	P3-4	TM26D	P10-5
CSMP105CA	P4-13	KS23PA	P5-4	PTP5S1CB	P3-4		
CSP087A	P4-3	KS23PB	P5-4	PTP5S3CB	P3-4		
CSP087B	P4-3	KS30A	P5-4	<b>S</b>			
CSS60A	P4-3	KS30B	P5-4	SP060A	P5-18		
CSS60B	P4-3	K2A	P9-9	SP080A	P5-18		
CSS80A	P4-3	K2C	P9-11	STE060PA	P5-4		
<b>D</b>		K3E	P9-5	STE060PB	P5-4		
DC6	P13-4	K3M	P9-7	STE080PA	P5-4		
DFM3	P12-1	<b>P</b>		STE080PB	P5-4		
DPA-LR1	P2-2	P085DB	P3-10	STE100PA	P5-4		
DPA-LR2	P2-4	P08SB	P3-10	STE100PB	P5-4		
DPA-PLR2B	P2-6	P10DA	P3-10	STM11A	P5-10		
DPA-SR1	P2-2	P10DB	P3-10	STM12A	P5-10		
DPA-SR2	P2-4	P10DHA	P3-16	STM31A	P5-10		
<b>E</b>		P10DHB	P3-16	STM32A	P5-10		
E2A	P9-13	P10DHLTB	P3-16	STM35A	P5-10		
<b>F</b>		P10DLB	P3-10	STM36A	P5-10		

## Discontinued Products

The following types are no longer listed.  
Please contact us for the service parts.

### ■ High-precision MT-Touch Switch

- P11GDB
- P11GMB
- P10MCA
- P10MCB
- CSR series
- CSC
- CSCHP
- CSCP

### ■ Machine Components with a Built-in Switch series

- STM13A
- STM14A
- STM33A
- STM34A
- STM61A
- STM63A
- STM64A
- STM81A
- STM83A
- STM84A
- KS51A
- KS51B

### ■ Special Purpose Switch series

- STM81A-HT1
- STM81A-HT2
- STM82A-HT1
- STS060A-HT1
- STS060A-HT2
- BP060A-HT1
- CS067A-HT1

### ■ Direct-out connector

- DG

### ■ Touch Probe Series for CNC Machine Tools

- K1A
- RC-K3E → Refer to the separate volume  
"High-Precision Compact TOUCH PROBE"

### ■ Tool Setter Series for CNC Machining Centers

- T24E-112
- T24E-220
- T20-220

### ■ Tool Setter Series for CNC Lathes

- H4A-002
- H4D



## Communication sheet

**FAX+81-42-528-1442**

**FAX**

METROL answers your question regarding contact switches.  
Write down your questions and send it to us by fax.

### ■ Please write down your questions

-----

-----

-----

-----

-----

### ■ Picture your application (Let us know about your application in detail as possible.)

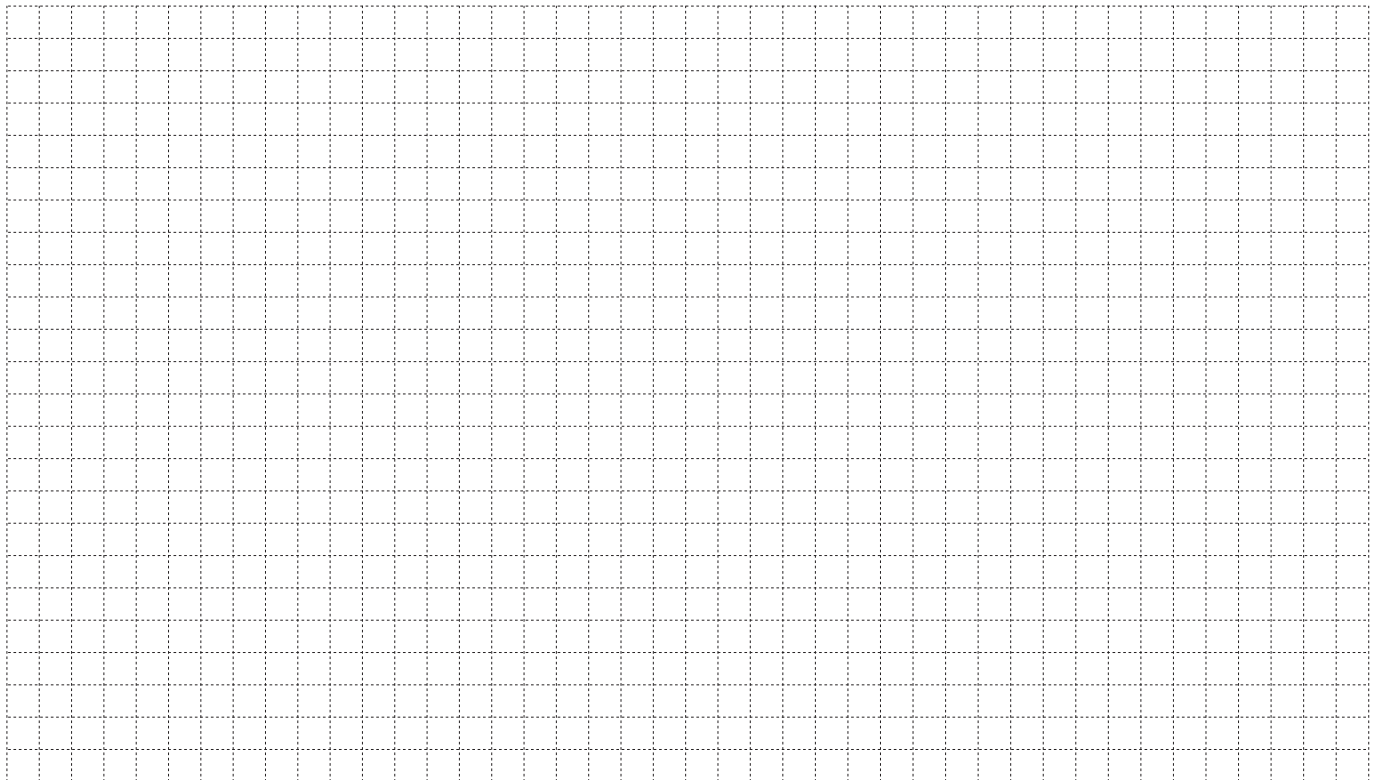

You may attach your business card here and fax us the copy.

Company name: \_\_\_\_\_

Name: \_\_\_\_\_

Address: \_\_\_\_\_

Function: \_\_\_\_\_

TEL: \_\_\_\_\_

FAX: \_\_\_\_\_

E-mail: \_\_\_\_\_

Please check in a blank

Machine tool builder

Machine tool user

Distributor

Others \_\_\_\_\_



Send us a fax regarding your application.  
 Our professional team will answer your questions.

**Example**

**Communication sheet**  
 METROL answers your question regarding contact sensors.  
 Write down your questions and send it to us by fax.

METROL CO., LTD.  
<http://www.metrol.co.jp/en>  
<http://toolsensor.com>  
**FAX +81-42-528-1442**  
**FAX**

Please write down your questions

I would like to measure  
 a depth of work.

Do you have any other set for the  
 up and down for measurement  
 pretravel 0.2mm  
 0.5 work common difference

Cylinder  
 PID

Draw the picture describing your application

Fill in the blanks

Write down your questions

Attach your business card optionally for copy and fax

Company Name : \_\_\_\_\_  
 Address : \_\_\_\_\_  
 Function : \_\_\_\_\_  
 TEL : \_\_\_\_\_  
 FAX : \_\_\_\_\_  
 E-mail : \_\_\_\_\_

Please check in a blank  
 Machine tool builder  
 Machine tool user  
 Distributor  
 Others \_\_\_\_\_

— Copy this page and use it repeatedly. —

**FAX+81-42-528-1442**

**FAX**



**The specifications and descriptions are subjected to change without notice due to improvements in products.**

TOKYO JAPAN **High-Precision Positioning Switch**  
 **Metrol**

**METROL CO., LTD.**  
1-100 Takamatsu-cho Tachikawa, Tokyo 190-0011 JAPAN  
Tel: +81 50 5558 7366 / Fax: +81 42 528 1442  
E-mail: [touchsensor@metrol.co.jp](mailto:touchsensor@metrol.co.jp)

2001-K001